

HMS30C7202N

Highly-integrated MPU
(ARM Based 32-Bit Microprocessor)

Datasheet

Version 1.1

MagnaChip Semiconductor Ltd.



Copyright. 2004 MagnaChip Semiconductor Ltd.

ALL RIGHTS RESERVED. No part of this publication may be copied in any form, by photocopy, microfilm, retrieval system, or by any other means now known or hereafter invented without the prior written permission of MagnaChip Semiconductor Ltd.

MagnaChip Semiconductor Ltd.

#1, Hyangjeong-dong, Heungduk-gu, Cheongju-si, Chungcheongbuk-do, Republic of Korea

Homepage: www.MagnaChip.com

Technical Support Homepage: www.softonchip.com

H.Q. of MagnaChip Semiconductor Ltd.

Telephone: 82-(0)43-270-4070

Facsimile: 82-(0)43-270-4099

Telephone: 82-(0)43-270-4085

Facsimile: 82-(0)43-270-4099

Marketing Site Sales in Korea

Telephone: 82-(0)2-3459-3843

Facsimile: 82-(0)2-3459-3945

World Wide Sales Network**U.S.A.**

Telephone: 1-408-232-8757

Facsimile: 1-408-232-8135

Taiwan

Telephone: 886-(0)2-2500-8357

Facsimile: 886-(0)2-2509-8977

Hong Kong

Telephone: 852-2971-1640

Facsimile: 852-2971-1622

HMS30C7202N Datasheet, ver1.1

June 16, 2004

Proprietary Notice

MagnaChip logo is trademark of MagnaChip Semiconductor Ltd.

Neither the whole nor any part of the information contained in, or the product described in, this document may be adapted or reproduced in any material from excepts with the prior permission of the copyright holder.

The product described in this document is subject to continuous developments and improvements. All particulars of the product and its use contained in this document are given by MagnaChip in good faith. However, all warranties implied or expressed , including but not limited to implied warranties or merchantability, or fitness for purpose, are excluded.

This document is intended only to assist the reader in the use of the product. MagnaChip Semiconductor Ltd. shall not be liable for any loss or damage arising from the use of any information in this document, or any error or omission in such information, or any incorrect use of the product. MagnaChip Semiconductor Ltd. may make changes to specification and product description at any time without notice.

Change Log

Issue	Date	By	Change
N-01	2003/09/15	Injae Koo	The First Release (Version 1.0)
N-02	2004/06/17	Injae Koo	ADC/GPIO/SDRAMC/MMC/LCD/AC Characteristics (SMI)

FEATURES

- 32-bit ARM7TDMI RISC static CMOS CPU core : Running up to 70 MHz
- 8Kbytes combined instruction/data cache
- Memory management unit
- Supports Little Endian operating system
- 2Kbytes SRAM for internal buffer memory
- On-chip peripherals with individual power-down:
 - Multi-channel DMA
 - 4 Timer Channels with Watch Dog Timer
 - Intelligent Interrupt Controller
 - Memory controller for ROM, Flash, SRAM, SDRAM
 - Power management unit
 - LCD Controller for mono/color STN and TFT LCD
 - Real-time clock (32.768kHz oscillator)
 - Infrared communications (SIR support)
 - 4 UARTs (16C550 compatible)
 - PS/2 External Keyboard / Mouse interface
 - 2 Pulse-Width-Modulated (PWM) interface
 - Matrix Keyboard control interface (8*8)
 - GPIO
 - MMC / SMC Card interface
 - USB (slave)
 - On-chip ADC and interface module (Battery Check, Audio In, Touch Panel)
 - On-chip DAC and interface module (8 Bit Stereo Audio Output)
 - 3 PLLs

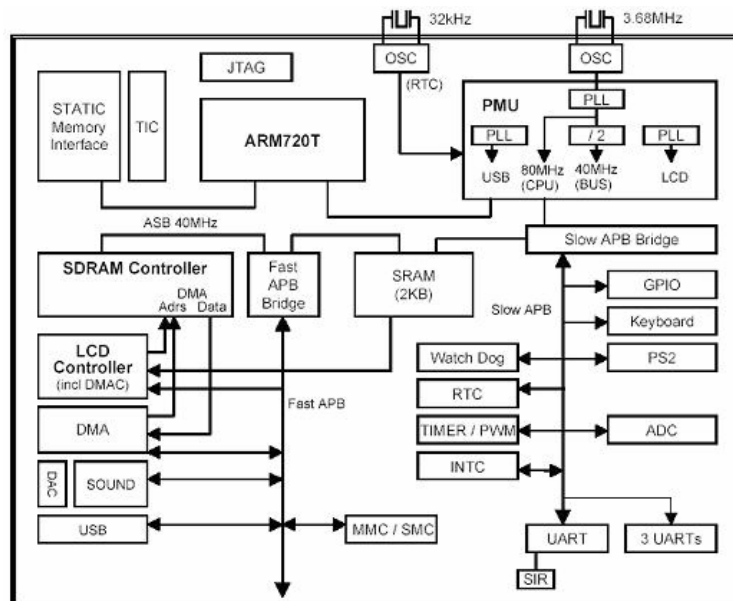

Figure A. Functional Block Diagram

- JTAG debug interface and boundary scan
- 0.25um Low Power CMOS Process
- 2.5V internal / 3.3V IO supply voltage
- 256-pin MQFP / FBGA package
- Low power consumption

OVERVIEW

The HMS30C7202 is a highly integrated low power microprocessor for personal digital assistants, and other applications described below. The device incorporates an ARM720T CPU and system interface logic to interface with various types of devices. HMS30C7202 is a highly modular design based on the AMBA bus architecture between CPU and internal modules.

The on-chip peripherals include LCD controller with DMA support for external SDRAM memory, analog functions such as ADC, DAC, and PLLs. Intelligent interrupt controller and internal 2Kbytes SRAM can support an efficient interrupt service execution. The HMS30C7202 also supports voice recording, sound playback and a touch panel interface. UART, USB, PS2 and CAN provide serial communication channels for external systems. The power management features result in very low power consumption. The HMS30C7202 provides an excellent solution for personal digital assistants (PDAs), and data terminal running the Microsoft Windows CE operating system. Other applications include smart phones, Internet appliances, telematic systems and embedded computer.

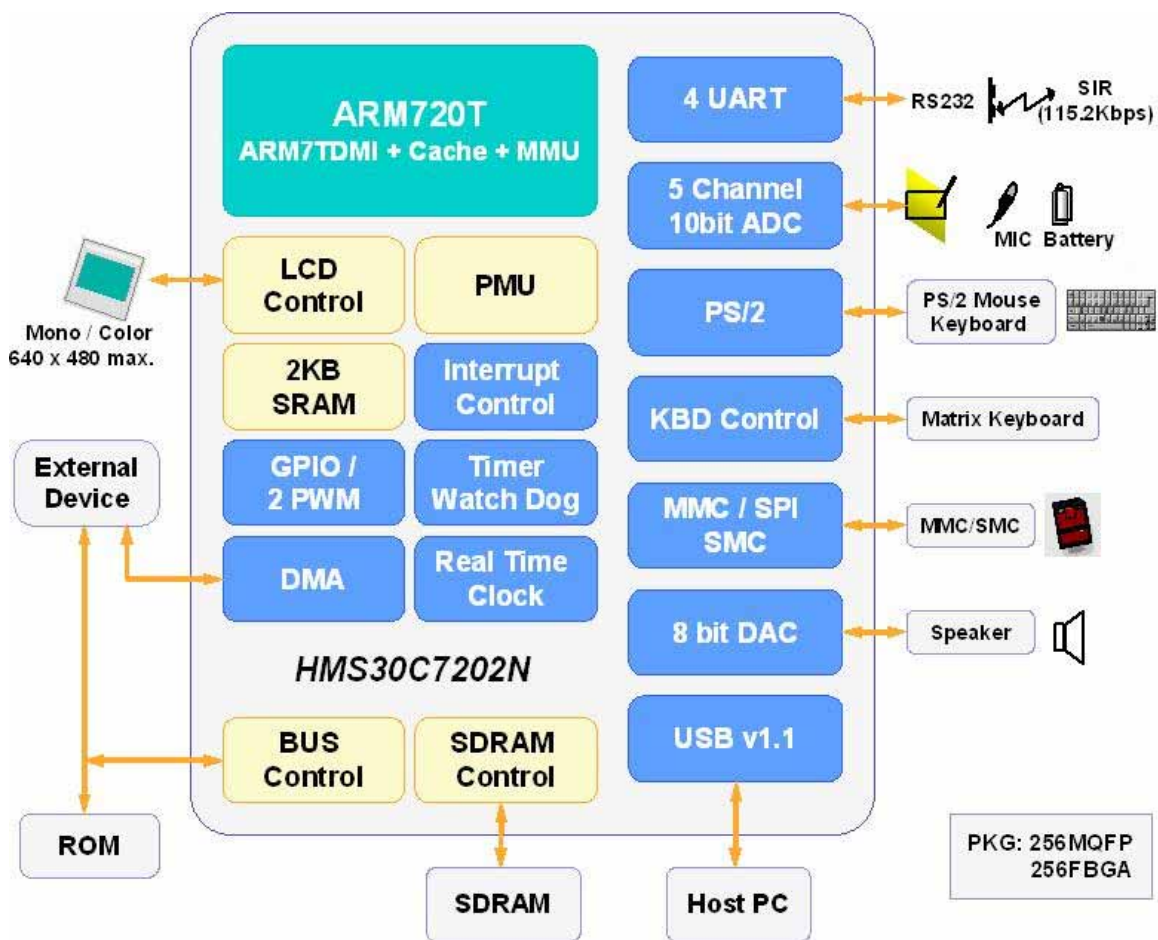

Figure B. System Configuration

TABLE OF CONTENTS

1	ARCHITECTURAL OVERVIEW	9
1.1	PROCESSOR.....	9
1.2	VIDEO	9
1.3	MEMORY	9
1.4	INTERNAL BUS STRUCTURE.....	9
1.4.1	ASB.....	9
1.4.2	Video bus	9
1.4.3	APB	9
1.5	SDRAM CONTROLLER.....	10
1.6	PERIPHERAL DMA.....	10
1.6.1	Overview.....	10
1.6.2	Transfer sizes.....	10
1.6.3	Fly-by	10
1.6.4	Timing.....	11
1.6.5	Sound output.....	11
1.7	PERIPHERALS	11
1.8	POWER MANAGEMENT	11
1.8.1	Clock gating	12
1.8.2	PMU.....	12
1.9	TEST AND DEBUG	12
2	PIN DESCRIPTION	13
2.1	256-PIN DIAGRAM.....	13
2.1.1	MQFP Type	13
2.1.2	FBGA Type	15
2.2	PIN DESCRIPTIONS	17
2.2.1	External Signal Functions	17
2.2.2	Multiple Function Pins	20
2.2.2.1	PORT A	20
2.2.2.2	PORT B	20
2.2.2.3	PORT C	21
2.2.2.4	PORT D	21
2.2.2.5	PORT E.....	22
2.2.2.6	USB Transceiver Test & Analog Test	23
2.2.2.7	DMA.....	23
2.2.2.8	Inverter Chain	23
3	ARM720T MACROCELL.....	24
3.1	ARM720T MACROCELL.....	24
4	MEMORY MAP.....	25
5	PMU & PLL.....	27
5.1	BLOCK FUNCTIONS	27
5.2	POWER MANAGEMENT	28
5.2.1	State Diagram.....	28
5.2.2	Power management states	28
5.2.3	Wake-up Debounce and Interrupt.....	29
5.3	REGISTERS.....	30
5.3.1	PMU Mode Register (PMUMODE)	30
5.3.2	PMU ID Register (PMUID).....	30
5.3.3	PMU Reset /PLL Status Register (PMUSTAT).....	30
5.3.4	PMU Clock Control Register (PMUCLK).....	32
5.3.5	PMU Debounce Counter Test Register (PMUDBCT).....	33
5.3.6	PMU PLL Test Register (PMUPLLTR).....	33
5.4	TIMINGS	34

5.4.1	Reset Sequences of Power On Reset.....	34
5.4.2	Software Generated Warm Reset.....	35
5.4.3	An Externally generated Warm Reset.....	35
6	SDRAM CONTROLLER.....	37
6.1	SUPPORTED MEMORY DEVICES.....	37
6.2	REGISTERS.....	38
6.2.1	SDRAM Controller Configuration Register (SDCON).....	38
6.2.2	SDRAM Controller Refresh Timer Register (SDREF).....	40
6.2.3	SDRAM Controller Write buffer flush timer Register (SDWBF).....	40
6.2.4	SDRAM Controller Wait Driver Register (SDWAIT).....	40
6.3	POWER-UP INITIALIZATION OF THE SDRAMs.....	40
6.4	SDRAM MEMORY MAP.....	41
6.5	AMBA ACCESSES AND ARBITRATION.....	42
6.6	MERGING WRITE BUFFER.....	42
7	STATIC MEMORY INTERFACE.....	44
7.1	EXTERNAL SIGNALS.....	44
7.2	FUNCTIONAL DESCRIPTION.....	44
7.2.1	Memory bank select.....	44
7.2.2	Access sequencing.....	44
7.2.3	Wait states generation.....	45
7.2.4	Burst read control.....	45
7.2.5	Byte lane write control.....	45
7.3	REGISTERS.....	46
7.3.1	MEM Configuration Register.....	46
7.4	EXAMPLES OF THE SMI READ, WRITE WAIT TIMING DIAGRAM.....	47
7.4.1	Read normal wait (Non-Sequential mode).....	47
7.4.2	Read normal wait (Sequential mode).....	48
7.4.3	Read burst wait (Sequential mode).....	49
7.4.4	Write normal wait (Sequential mode).....	50
7.5	INTERNAL SRAM.....	51
7.5.1	Remapping Enable Register.....	51
7.5.2	Remap Source Address Register.....	51
8	LCD CONTROLLER.....	52
8.1	VIDEO OPERATION.....	52
8.1.1	LCD datapath.....	53
8.1.1.1	Palette RAM & 16bpp mode.....	53
8.1.2	Color/Grayscale Dithering.....	55
8.1.3	How to order the bit on LD[7:0] output.....	55
8.1.4	TFT mode.....	56
8.2	REGISTERS.....	56
8.2.1	LCD Power Control.....	56
8.2.2	LCD Controller Status/Mask and Interrupt Registers.....	57
8.2.3	LCD DMA Base Address Register.....	58
8.2.4	LCD DMA Channel Current Address Register.....	58
8.2.5	LCD Timing 0 Register.....	58
8.2.6	LCD Timing 1 Register.....	59
8.2.7	LCD Timing 2 Register.....	60
8.2.8	LCD Test Register.....	61
8.2.9	Grayscale Test Registers.....	61
8.2.10	LCD Palette registers.....	62
8.3	TIMINGS.....	63
9	FAST AMBA PERIPHERALS.....	64
9.1	DMA CONTROLLER.....	64
9.1.1	External Signals.....	64
9.1.2	Registers.....	64
9.1.2.1	ADR0.....	65

9.1.2.2	ASR	65
9.1.2.3	TNR0	65
9.1.2.4	TSR	65
9.1.2.5	CCR0	65
9.1.2.6	ADR1	66
9.1.2.7	TNR1	66
9.1.2.8	CCR1	66
9.1.2.9	ADR2	66
9.1.2.10	TNR2	66
9.1.2.11	CCR2	67
9.1.2.12	FLAGR	67
9.1.2.13	DMAOR	67
9.1.3	<i>DMAC operation</i>	68
9.2	MMC/ SPI CONTROLLER	69
9.2.1	<i>External Signals</i>	69
9.2.2	<i>Registers (SPI Mode)</i>	69
9.2.2.1	SPIMMC Control Register (SPICR)	69
9.2.2.2	SPIMMC Status Register (SPISR)	70
9.2.2.3	SPIMMC XCH Counter Register (XHCNT)	70
9.2.2.4	SPIMMC TX Data Buffer Register (TXBUFF)	70
9.2.2.5	SPIMMC RX Data Buffer Register (RXBUFF)	70
9.2.2.6	SPIMMC Reset Register (ResetReg)	71
9.2.3	<i>Timings</i>	71
9.2.4	<i>SPI Operation for MMC</i>	72
9.2.5	<i>Multimedia Card Host Controller</i>	73
9.2.6	<i>Registers</i>	73
9.2.6.1	MMC Mode Register	73
9.2.6.2	MMC Operation Register	74
9.2.6.3	MMC Status Register	74
9.2.6.4	MMC Interrupt Enable Register	75
9.2.6.5	MMC Block Size Register	76
9.2.6.6	MMC Block Number Register	76
9.2.6.7	MMC Time Period Register	76
9.2.6.8	MMC Command Buffer Register	76
9.2.6.9	MMC Argument Buffer Register	76
9.2.6.10	MMC Response Buffer Register	77
9.2.6.11	MMC Data Buffer Register	77
9.2.6.12	MMC Ready Timeout Register	77
9.2.7	<i>Basic Operation in MMC Mode</i>	77
9.2.7.1	Write Operation	78
9.2.7.2	Read Operation	78
9.3	SMC CONTROLLER	79
9.3.1	<i>External Signals</i>	79
9.3.2	<i>Registers</i>	79
9.3.2.1	SMC Command Register (SMCCMD)	79
9.3.2.2	SMC Address Register (SMCADR)	80
9.3.2.3	SMC Data Write Register (SMCDATW)	80
9.3.2.4	SMC Data Read Register (SMCDATR)	81
9.3.2.5	SMC Configuration Register (SMCCONF)	81
9.3.2.6	SMC Timing Parameter Register (SMCTIME)	82
9.3.2.7	SMC Status Register (SMCSTAT)	82
9.4	SOUND INTERFACE	84
9.4.1	<i>External Signals</i>	84
9.4.2	<i>Registers</i>	84
9.4.2.1	SCONT	84
9.4.2.2	SDADR	85
9.5	USB SLAVE INTERFACE	86
9.5.1	<i>Block Diagram</i>	87
9.5.2	<i>Theory of Operation</i>	87
9.5.3	<i>Endpoint FIFOs (Rx, Tx)</i>	90

9.5.4	External Signals	90
9.5.5	Registers.....	90
9.5.5.1	GCTRL.....	90
9.5.5.2	EPCTRL.....	90
9.5.5.3	INTMASK.....	91
9.5.5.4	INTSTAT.....	91
9.5.5.5	PWR.....	92
9.5.5.6	DEVID.....	92
9.5.5.7	DEVCLASS.....	92
9.5.5.8	INTCLASS.....	92
9.5.5.9	SETUP0 / SETUP1	94
9.5.5.10	ENDPORD.....	94
9.5.5.11	ENDP0WT.....	94
9.5.5.12	ENDP1RD.....	94
9.5.5.13	ENDP2WT.....	94
10	SLOW AMBA PERIPHERALS.....	95
10.1	ADC INTERFACE CONTROLLER.....	95
10.1.1	External Signals	95
10.1.2	Registers.....	95
10.1.2.1	ADC Control Register (ADCCR).....	96
10.1.2.2	ADC Touch Panel Control Register (ADCTPCR).....	96
10.1.2.3	ADC Battery check Control Register (ADCBACR).....	97
10.1.2.4	ADC Sound Control Register (ADCSDCR).....	97
10.1.2.5	ADC Interrupt Status Register (ADCISR).....	97
10.1.2.6	ADC Tip Down Control Status Register (ADCTDCSR).....	98
10.1.2.7	ADC Direct Control Register (ADCDIRCR).....	98
10.1.2.8	ADC Direct Data Read Register (ADCDIRDATA).....	98
10.1.2.9	ADC 1 ST Touch Panel Data register.....	99
10.1.2.10	ADC 2 ND Touch Panel Data Register.....	99
10.1.2.11	ADC Main Battery Data Register (ADCMBDATA).....	100
10.1.2.12	ADC Backup Battery Data Register (ADCBBDATA).....	100
10.1.2.13	ADC Sound Data Register (ADCSDATA0 – ADCSDATA7).....	100
10.2	GPIO.....	102
10.2.1	External Signals	102
10.2.2	Registers.....	102
10.2.2.1	ADATA.....	103
10.2.2.2	ADIR.....	103
10.2.2.3	AMASK.....	104
10.2.2.4	ASTAT.....	104
10.2.2.5	AEDGE.....	104
10.2.2.6	ACLR.....	104
10.2.2.7	APOL.....	104
10.2.2.8	GPIO PORT A Enable Register.....	104
10.2.2.9	BDATA.....	105
10.2.2.10	BDIR.....	105
10.2.2.11	BMASK.....	105
10.2.2.12	BSTAT.....	105
10.2.2.13	BEDGE.....	105
10.2.2.14	BCLK.....	105
10.2.2.15	BPOL.....	105
10.2.2.16	GPIO PORT B Enable Register.....	105
10.2.2.17	CDATA.....	105
10.2.2.18	CDIR.....	105
10.2.2.19	CMASK.....	106
10.2.2.20	CBSTAT.....	106
10.2.2.21	CEDGE.....	106
10.2.2.22	CCLK.....	106
10.2.2.23	CPOL.....	106
10.2.2.24	GPIO PORT C Enable Register.....	106

10.2.2.25	DDATA	106
10.2.2.26	DDIR	106
10.2.2.27	DMASK	106
10.2.2.28	DBSTAT	106
10.2.2.29	DEDGE	106
10.2.2.30	DCLK	106
10.2.2.31	DPOL	106
10.2.2.32	GPIO PORT D Enable Register	106
10.2.2.33	EDATA	107
10.2.2.34	EDIR	107
10.2.2.35	EMASK	107
10.2.2.36	EBSTAT	107
10.2.2.37	EEDGE	107
10.2.2.38	ECLK	107
10.2.2.39	EPOL	107
10.2.2.40	GPIO PORT E Enable Register	107
10.2.2.41	Tic Test mode Register(TICTMDR)	107
10.2.2.42	PORTA Multi-function Select register(AMULSEL)	108
10.2.2.43	SWAP Pin Configuration Register(SWAP)	108
10.2.3	GPIO Interrupt	108
10.2.4	GPIO Rise/Fall Time	109
10.3	INTERRUPT CONTROLLER	110
10.3.1	Block diagram	110
10.3.2	Registers	110
10.3.2.1	Interrupt Enable Register (IER)	111
10.3.2.2	Interrupt Status Register (ISR)	112
10.3.2.3	IRQ Vector Register (IVR)	113
10.3.2.4	Source Vector Register (SVR0 to SVR30)	113
10.3.2.5	Interrupt ID Register (IDR)	113
10.3.2.6	Priority Set Register (PSR0 to PSR7)	113
10.4	MATRIX KEYBOARD INTERFACE CONTROLLER	115
10.4.1	External Signals	115
10.4.2	Registers	115
10.4.2.1	Keyboard Configuration Register (KBCR)	116
10.4.2.2	Keyboard Scanout Register(KBSC)	116
10.4.2.3	Keyboard Test Register (KBTR)	117
10.4.2.4	Keyboard Value Register (KVR0)	117
10.4.2.5	Keyboard Value Register (KVR1)	117
10.4.2.6	Keyboard Status Register (KBSR)	117
10.5	PS/2 INTERFACE CONTROLLER	119
10.5.1	External Signals	119
10.5.2	Registers	119
10.5.2.1	PSDATA	119
10.5.2.2	PSSTAT	120
10.5.2.3	PSCONF	120
10.5.2.4	PSINTR	121
10.5.2.5	PSTDLO	121
10.5.2.6	PSTPRI	121
10.5.2.7	PSTXMT	122
10.5.2.8	PSTREC	122
10.5.2.9	PSPWDN	123
10.5.3	Application Notes	123
10.6	RTC	124
10.6.1	External Signals	125
10.6.2	Functional Description	125
10.6.3	Registers	125
10.6.3.1	RTC Data Register (RTCDR)	125
10.6.3.2	RTC Match Register (RTCMR)	126
10.6.3.3	RTC Status Register (RTCS)	126
10.6.3.4	RTC Control Register (RTCCR)	126

10.7	TIMER	127
10.7.1	External Signals	127
10.7.2	Registers	127
10.7.2.1	Timer [0,1,2] Base Register (T[0,1,2]BASE)	127
10.7.2.2	Timer [0,1,2] Count Register (T[0,1,2]COUNT)	128
10.7.2.3	Timer [0,1,2] Control Register (T[0,1,2]CTRL)	128
10.7.2.4	Timer Top-level Control Register (TOPCTRL)	128
10.7.2.5	Timer Status Register (TOPSTAT)	129
10.7.2.6	Timer Lower 32-bit Count Register of 64-bit Counter (T64LOW)	129
10.7.2.7	Timer Upper 32-bit Count Register of 64-bit Counter (T64HIGH)	129
10.7.2.8	Timer 64-bit Counter Control Register (T64CTRL)	129
10.7.2.9	Timer 64-bit Counter Test Register (T64TR)	129
10.7.2.10	Timer Lower 32-bit Base Register of 64-bit Counter (T64LBASE)	130
10.7.2.11	Timer Upper 32-bit Base Register of 64-bit Counter (T64HBASE)	130
10.7.2.12	PWM Channel [0,1] Count Register (P[0,1]COUNT)	130
10.7.2.13	PWM Channel [0,1] Width Register (P[0,1]WIDTH)	131
10.7.2.14	PWM Channel [0,1] Period Register (P[0,1]PERIOD)	131
10.7.2.15	PWM Channel [0,1] Control Register (P[0,1]CTRL)	131
10.7.2.16	PWM Channel[0,1] Test Register(P[0,1]PWMTR)	131
10.8	UART/SIR	132
10.8.1	External Signals	132
10.8.2	Registers	133
10.8.2.1	RBR/THR/DLL	134
10.8.2.2	IER/DLM	134
10.8.2.3	IIR/FCR	134
10.8.2.4	LCR	136
10.8.2.5	MCR	137
10.8.2.6	LSR	138
10.8.2.7	MSR	139
10.8.2.8	SCR	140
10.8.2.9	UartEn	140
10.8.3	FIFO Interrupt Mode Operation	140
10.9	WATCHDOG TIMER	142
10.9.1	Watchdog Timer Operation	142
10.9.1.1	The Watchdog Timer Mode	142
10.9.1.2	The Interval Timer Mode	142
10.9.1.3	Timing of setting the overflow flag	143
10.9.1.4	Timing of clearing the overflow flag	143
10.9.2	Registers	143
10.9.2.1	WDT Control Register (WDTCTRL)	143
10.9.2.2	WDT Status Register (WDTSTAT)	144
10.9.2.3	WDT Counter (WDCNT)	144
10.9.3	Examples of Register Setting	145
10.9.3.1	Interval Timer Mode	145
10.9.3.2	Watchdog Timer Mode with Internal Reset Disable	145
10.9.3.3	Watchdog Timer Mode with Manual Reset	146
11	DEBUG AND TEST INTERFACE	147
11.1	OVERVIEW	147
11.2	SOFTWARE DEVELOPMENT DEBUG AND TEST INTERFACE	147
11.3	TEST ACCESS PORT AND BOUNDARY-SCAN	147
11.3.1	Reset	148
11.3.2	Pull up Resistors	148
11.3.3	Instruction Register	149
11.3.4	Public Instructions	149
11.3.5	Test Data Registers	151
11.3.6	Boundary Scan Interface Signals	152
11.4	PRODUCTION TEST FEATURES	160
12	ELECTRICAL CHARACTERISTICS	161

12.1	ABSOLUTE MAXIMUM RATINGS	161
12.2	DC CHARACTERISTICS	162
12.3	A/D CONVERTER ELECTRICAL CHARACTERISTICS	163
12.4	D/A CONVERTER ELECTRICAL CHARACTERISTICS	164
12.5	AC CHARACTERISTICS	165
12.5.1	<i>Static Memory Interface</i>	165
12.5.1.1	READ Access Timing (Single Mode).....	165
12.5.1.2	READ Access Timing (Burst Mode)	166
12.5.1.3	WRITE Access Timing	167
12.5.2	<i>SDRAM Interface</i>	168
12.5.3	<i>LCD Interface</i>	169
12.5.4	<i>UART(Universal Asynchronous Receiver Transmitter)</i>	171
12.6	PACKAGE	172
12.6.1	<i>Recommended Soldering Conditions</i>	172
12.6.1.1	MQFP(Metric Quad Flat Pack) Type	172
12.6.1.2	FBGA(Chip Array Ball Grid Array) Type.....	172
12.6.2	<i>Pictures of Package Marking</i>	173
13	APPENDIX	174
13.1	DEEP-SLEEP, WAKE-UP ISSUES OF HMS30C7202 PMU	174
13.1.1	<i>Wake-up</i>	174
13.1.2	<i>Deep-sleep</i>	174

LIST OF FIGURES

Figure 5-1 PMU Power Management State Diagram.....	28
Figure 5-2 PMU Cold Reset Event	34
Figure 5-3 PMU Software Generated Warm Reset.....	35
Figure 5-4 PMU An Externally Generated Warm Reset.....	36
Figure 6-1 SDRAM Controller Software Example and Memory Operation Diagram	39
Figure 8-1 Video System Block Diagram	52
Figure 8-2 5:6:5 Combination of 16bpp Data	53
Figure 8-3 Palette RAM Entries for 5:6:5 Combination	54
Figure 8-4 Sample Code for 5:6:5 Palette Generation.....	54
Figure 8-5 LCD Palette Word Bit Field for STN mode	62
Figure 8-6 LCD Palette Word Bit Field for TFT mode	62
Figure 8-7 Example Mono STN LCD Panel Signal Waveforms	63
Figure 8-8 Example TFT Signal Waveforms, Start of Frame	63
Figure 8-9 Example TFT Signal Waveforms, End of Last Line	63
Figure 9-1 USB Block Diagram.....	87
Figure 9-2 USB Serial Interface Engine.....	88
Figure 9-3 USB Device Interface Device Controller.....	89
Figure 10-3 Interrupt controller block diagram	110
Figure 10-4 A flow chart of the keyboard controller.....	115
Figure 10-5 PS/2 Controller Transmitting Data Timing Diagram	121
Figure 10-6 PS/2 Controller Receiving Data Timing Diagram	122
Figure 10-7 RTC Connection	124
Figure 10-8 RTC Block Diagram.....	125
Figure 10-9 WDT Operation in the Watchdog Timer mode	142
Figure 10-10 WDT Operation in the Interval Timer mode	143
Figure 10-11 Interrupt Clear in the interval timer mode.....	145
Figure 10-12 Interrupt Clear in the watchdog timer mode with reset disable	146
Figure 10-13 Interrupt Clear in the watchdog timer mode with manual reset.....	146

LIST OF TABLES

Table 2-1 Pin Signal Type Definition	17
Table 2-2 External Signal Functions	19
Table 4-1 Top-level address map	25
Table 4-2 Peripherals Base Addresses	26
Table 5-1 PMU Register Summary	30
Table 5-2 PMU Bit Settings for a cold Reset Event within PMUSTAT Register.....	35
Table 5-3 PMU Bit Settings for a Software Generated Warm Reset within PMUSTAT Register	35
Table 5-4 PMU Bit Settings for a Warm Reset within PMUSTAT Register	36
Table 6-1 SDRAM Controller Register Summary	38
Table 6-2 SDRAM Row/Column Address Map.....	41
Table 6-3 SDRAM Device Selection	42
Table 7-1 Static Memory Controller Register Summary	46
Table 8-1 LCD Colorgrayscale intensities and modulation rates.....	55
Table 8-2 How to order the bit on LD[7:0] in 8-bit color STN mode.....	56
Table 8-3 LCD Controller Register Summary.....	56
Table 9-1 DMA Controller Register Summary	65
Table 10-1 ADC Controller Register Summary	95
Table 10-2 Interrupt controller Configuration.....	110
Table 10-3 Interrupt controller Register Summary	111
Table 10-4 Matrix Keyboard Interface Controller Register Summary	116
Table 10-5 PS/2 Controller Register Summary	119
Table 10-6 Non-AMBA Signals within RTC Core Block.....	124
Table 10-7 RTC Register Summary	125
Table 10-8 Timer Register Summary	127
Table 10-9 UART/SIR Register Summary.....	134
Table 10-10 Baud Rate with Decimal Divisor at 3.6864MHz Crystal Frequency.....	137
Table 10-11 Watchdog Timer Register Summary.....	143

1 ARCHITECTURAL OVERVIEW

1.1 Processor

The ARM720T core incorporates an 8K unified write-through cache, and an 8 data entry, 4-address entry write buffer. It also incorporates an MMU with a 64 entry TLB, and WinCE enhancements.

1.2 Video

The integrated LCD controller can control STN displays and TFT displays, up to 640x480 (VGA) resolution and 16bit color. On mono displays it can directly generate 16 gray scales.

1.3 Memory

HMS30C7202 incorporates two independent memory controllers. A high-speed 16-bit wide interface connects directly to one or two 16, 64, 128 or 256MBit SDRAM devices, supporting DRAM memory sizes in the range 2 to 64MB. A separate 32-bit data path interfaces to ROM or Flash devices. Burst mode ROMs are supported, for increased performance, allowing operating system code to be executed directly from ROM. Since the ROM and SDRAM interfaces are independent, the processor core can execute ROM code simultaneously with video DMA access to the SDRAM, thus increasing total effective memory bandwidth, and hence overall performance.

1.4 Internal Bus Structure

The HMS30C7202 internal bus organization is based upon the AMBA standard, but with some minor modifications to the peripheral buses (the APBs). There are three main buses in the HMS30C7202:

1. The main system bus (the ASB) to which the CPU and memory controllers are connected
2. The fast APB to which high-bandwidth peripherals are connected
3. The slow APB (to which timers, the UART and other low-bandwidth peripherals are connected)

There is also a separate video DMA bus.

1.4.1 ASB

The ASB is designed to allow the ARM continuous access to both, the ROM and the SDRAM interface. The SDRAM controller straddles both the ASB and the video DMA bus so the LCD can access the SDRAM controller simultaneously with activity on the ASB. This means that the ARM can read code from ROM, or access a peripheral, without being interrupted by video DMA.

The HMS30C7202 uses a modified arbiter to control mastership on the main ASB bus. The arbiter only arbitrates on quad-word boundaries, or when the bus is idle. This is to get the best performance with the ARM720T, which uses a quad-word cache line, and also to get the best performance from the SDRAM, which uses a burst size of eight half-words per access. By arbitrating only when the bus is idle or on quad-word boundaries ($A[3:2] = 11$), it ensures that cache line fills are not broken up, hence SDRAM bursts are not broken up.

The SDRAM controller controls video ASB arbitration. This is explained in 6.5 Arbitration on page 39.

1.4.2 Video bus

The video bus connects the LCD controller with the SDRAM controller. Data transfers are DMA controlled. The video bus consists of an address bus, data bus and control signals to/from the SDRAM controller. The LCD registers are programmed through the fast APB. The SDRAM controller arbitrates between ASB, VGA access requests. Video always has higher priority than ASB access requests. The splitting ASB/video bus allows slow ASB device accesses SDRAM without blocking video DMA.

1.4.3 APB

There are two APB buses, the fast and slow APB bus. The fast APB bus operates at the speed of the ASB, and hosts the USB interface, the sound output interface, the LCD registers, etc. These are the high performance peripherals, which are generally DMA targets. The slow APB peripherals generally operate at the UART crystal clock frequency of 3.6864MHz, though register access via the APB is at ASB speed.

The slow APB peripherals do not support DMA transfers. This arrangement of running most of the peripherals at a slower clock, and reducing the load on the faster bus, results in significantly reduced power consumption. Both APB buses connect to the main ASB bus via bridges. The slow APB bridge takes care of all resynchronization, handing over data and control signals between the ASB and UART clock domains in a safe and reliable manner.

The fast APB Bridge is modified from the normal AMBA Bridge, to allow DMA access to fast APB peripherals. Additional signals from the DMA controller to the APB bridge request select and acknowledge DMA transfers to and from DMA-aware peripherals.

1.5 SDRAM Controller

The SDRAM controller is a key part of the HMS30C7202 architecture. The SDRAM controller has two data ports - one for video DMA and one for the main ASB - and interfaces to 16-bit wide SDRAMs. One to four 16, 64, 128, or 256 Mbit x16-bit devices are supported, giving a memory size ranging from 2 to 64 Mbytes.

The main ASB and video DMA buses are independent, and operate concurrently. The video bus has always higher priority than the main bus.

The video interface consists of address, data and control signals. The video access burst size is fixed to 16 words. The address is non-incrementing for words within a burst (as the SDRAM controller only makes use of the first address for each burst request).

1.6 Peripheral DMA

1.6.1 Overview

HMS30C7202 incorporates a four-channel, general-purpose DMA controller that operates on the ASB. The DMA controller is an AMBA compliant ASB bus master with a higher arbitration priority than the ARM processor, to ensure low DMA latency. Since, however, the main ASB bus always has lower priority access to the SDRAM controller than the video bus, it will always get lower priority access to SDRAM than the LCD.

1.6.2 Transfer sizes

A device that uses the peripheral DMA is the Sound output. The sound output data rate is 88.2KB/sec. To ensure reasonable usage of SDRAM, APB and ASB bandwidth, the transfer sizes to the sound controller is a single word.

The SDRAM controller does a complete quad-word access for every SDRAM access. The maximum SDRAM bandwidth taken by sound device running concurrently is 0.75%.

DMA accesses to Sound blocks are fully AMBA compliant, meaning that a word transfer takes two bus cycles.

1.6.3 Fly-by

The DMA controller is tightly coupled to the fast APB Bridge. In order for the DMA Controller to start a transfer, it must first receive a DMA data request from one of the peripherals; it will then request mastership of the ASB. Once granted, the DMA Controller will retain mastership of the ASB until the requested DMA transaction is completed, which ensures correct data in the DMA peripherals (i.e. the ARM core cannot modify data while a DMA transfer is in progress).

The DMA transfer request is monitored by the Fast APB bridge, which performs the correspondent APB transfer by inverting the read/write line with respect to the ASB and generates a PWRITE signal on the APB. The DMA transfer is acknowledged on the APB by asserting a PSELDMA signal for the given peripheral. The data is timed by PSTB as on a normal APB transfer. The APB address PA is not used for DMA transfers.

The APB bridge receives two signals from the DMA controller called CHAN [1:0], which tells it which DMA channel (peripheral) the DMA access is for. All other information comes from monitoring the ASB bus signals. For example, the direction of transfer comes from BWRITE (the sense is inverted to get the APB signal), and

when the SDRAM transfer completes, comes from the bridge monitoring the BWAIT ASB signal.

1.6.4 Timing

This is detailed in Chapter 9, Fast AMBA Peripherals.

1.6.5 Sound output

In the HMS30C7202, the sound peripheral is connected to the fast APB bus and supported by the DMA controller. (Note that this is compatible with some operating systems, which require DMA-support sound hardware.)

1.7 Peripherals

Universal Serial Bus (USB) device controller

The USB device controller is used to transfer data from/to host system like PC in high-speed (12Mbits/s) mode. No external USB transceiver is necessary.

PS/2 Interface

The PS/2 port can be used with keyboard, mice or other PS/2 compliant devices. In PS/2 mode the pins are open-drain I/Os, as GPIOs they have normal characteristics.

Universal Asynchronous Receiver and Transmitter (UART)

Four UART ports are implemented. One of them supports full modem interface signals. Some pins are used as GPIO or matrix keyboard pins when not used for UART.

IrDA

IrDA uses UART1 for its SIR transfer in 115 Kbit/s speed. The pins are used as GPIO or matrix keyboard pins when not used for IrDA.

Multimedia Card (MMC), Solid State Floppy Disk Card (SSFDC)

MMC or SSFDC memory card can be used as storage device. The pins are used as GPIO when not used for MMC or SSFDC.

Pulse-Width-Modulated (PWM) Interface

Two PWM output signals are generated. The pins are used as GPIO when not used for PWM.

Matrix Keyboard Interface

Matrix keyboard interface supports up to 64 keys. The pins are used as GPIO when not used for matrix keyboards.

General Purpose DMA Channel

One DMA channel is provided for external device that needs DMA access. The pins are used as GPIO when not used for DMA.

DAC

On chip DAC provides 8-bit audio stereo sound.

ADC

A 5 channel ADC is implemented for touch panel, audio input and monitoring of two voltages. No external transistor switch is necessary for touch panel operation.

PLL

CPU, video and USB clocks are generated by three PLL with 3.6864 MHz input clock.

1.8 Power management

The HMS30C7202 incorporates advanced power management functions, allowing the whole device to be put into a standby mode, when only the real time clock runs. The SDRAM is put into low-power self-refresh mode to preserve its contents. The HMS30C7202 may be forced out of this state by either a real-time clock wake-up interrupt, a user wake-up event (which would generally be a user pressing the "on" key) or by the UART ring-indicate input. The power management unit (PMU) controls the safe exit from standby mode to operational mode, ensuring that SDRAM contents are preserved. In addition, halt and slow modes allow the processor to be halted or run at reduced speed to reduce power consumption. The processor can be quickly brought out of the halted state by a peripheral interrupt. The advanced power management unit controls all this functionality. In addition, individual devices and peripherals may be powered down when they are not in use. The HMS30C7202 is designed for battery-powered portable applications and incorporates innovative design features in the bus structure and the PMU to reduce power consumption. The slow APB bus allows

peripherals to be clocked slowly hence reducing power consumption. The use of three buses reduces the number of nodes that are toggled during a data access, and thereby further reducing power consumption. In addition, clocks to peripherals that are not active can also be gated.

1.8.1 Clock gating

The high performance peripherals, such as the SDRAM controller and the LCD controller, run most of the time at high frequencies and careful design, including the use of clock gating, has minimized their power consumption. Any peripherals can be powered down completely when not in use.

1.8.2 PMU

The Power Management Unit (PMU) is used to control the overall state the system is in. The system can be in one of five states:

Run

The system is running normally. All clocks are running (except where gated locally), and the SDRAM controller is performing normal refresh.

Slow

The system operates normally, except the ARM is placed into Fast Bus mode, and hence is clocked at half its normal rate.

Idle

In this mode, the PMU becomes the bus master until there is an interrupt for the CPU, or the peripheral DMA controller requests mastership of the bus.

Sleep

The SDRAM is placed into self-refresh mode, and internal clocks are gated off. This mode can only be entered from Idle mode (that is, the PMU must be ASB master before this mode can be entered). The PMU must get bus mastership to ensure that the system is stopped in a safe state and not, for example, halfway through an SDRAM write. Usually this state is only to be entered briefly, on the way to entering deep sleep mode.

Deep Sleep

In deep sleep mode, the 3.6864MHz oscillator and the PLLs are disabled. This is the lowest power state available. Only the 32kHz oscillator runs. The real time clock and wakeup sections of the PMU are operated from this clock. Everything else is powered down, and SDRAM is in self-refresh mode. This is the normal system "off" mode. Sleep and Deep Sleep modes are exited either by a user wake-up event (generally pressing the "On" key), an RTC wake-up alarm, a device reset request, or by a modem ring indicate event. These interrupt sources go directly to the PMU. In addition, the modem ring indicate signal also goes to the normal interrupt controller to signal an interrupt if there is a ring indicate event in a non-sleep mode.

1.9 Test and debug

The HMS30C7202 incorporates the ARM standard test interface controller (TIC) allowing 32-bit parallel test vectors to be passed onto the internal bus. This allows access to the ARM720T macro-cell core, and also to memory mapped devices and peripherals within the HMS30C7202. In addition, the ARM720T includes support for the ARM debug architecture (Embedded ICE), which makes use of a JTAG boundary scan port to support debug of code on the embedded processor. The same boundary scan port is also used to support a normal pad-ring boundary scan for board level test applications.]

2 PIN DESCRIPTION

2.1 256-Pin Diagram

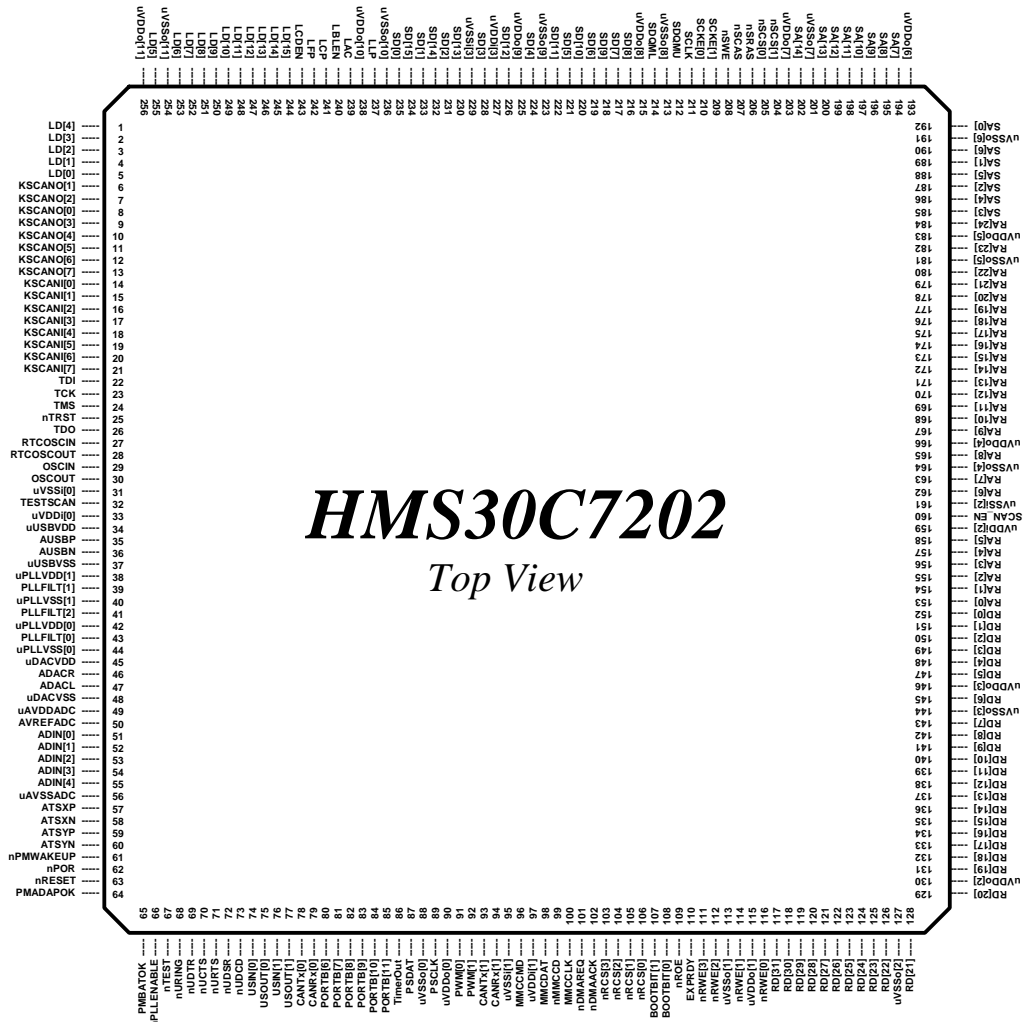

2.1.1 MQFP Type

Lead Count	Body Size	Body Thickness	Lead Pitch	Lead Form	Standoff
256	28.0X28.0	3.37	.40	1.30	.13

Note : All dimensions in mm.

Pin No.	PAD Name	Pin No.	PAD Name	Pin No.	PAD Name	Pin No.	PAD Name
1	LD[4]	65	PMBATOK	129	RD[20]	193	uVDDo6
2	LD[3]	66	nPLENABLE	130	uVDDo2	194	SA[7]
3	LD[2]	67	nTEST	131	RD[19]	195	SA[8]
4	LD[1]	68	nURING	132	RD[18]	196	SA[9]
5	LD[0]	69	nUDTR	133	RD[17]	197	SA[10]
6	KSCANO[1]	70	nUCTS	134	RD[16]	198	SA[11]
7	KSCANO[2]	71	nURTS	135	RD[15]	199	SA[12]

8	KSCANO[0]	72	nUDSR	136	RD[14]	200	SA[13]
9	KSCANO[3]	73	nUDCD	137	RD[13]	201	uVSSo7
10	KSCANO[4]	74	USIN[0]	138	RD[12]	202	SA[14]
11	KSCANO[5]	75	USOUT[0]	139	RD[11]	203	uVDDo7
12	KSCANO[6]	76	USIN[1]	140	RD[10]	204	nSCS[1]
13	KSCANO[7]	77	USOUT[1]	141	RD[9]	205	nSCS[0]
14	KSCANI[0]	78	PORTC[1]	142	RD[8]	206	nSRAS
15	KSCANI[1]	79	PORTC[2]	143	RD[7]	207	nSCAS
16	KSCANI[2]	80	PORTB[6]	144	uVSSo3	208	nSWE
17	KSCANI[3]	81	PORTB[7]	145	RD[6]	209	SCKE[1]
18	KSCANI[4]	82	PORTB[8]	146	uVDDo3	210	SCKE[0]
19	KSCANI[5]	83	PORTB[9]	147	RD[5]	211	SCLK
20	KSCANI[6]	84	PORTB[10]	148	RD[4]	212	SDQMU
21	KSCANI[7]	85	PORTB[11]	149	RD[3]	213	uVSSo8
22	TDI	86	TimerOut	150	RD[2]	214	SDQML
23	TCK	87	PSDAT	151	RD[1]	215	uVDDo8
24	TMS	88	uVSSo0	152	RD[0]	216	SD[8]
25	nTRST	89	PSCLK	153	RA[0]	217	SD[7]
26	TDO	90	uVDDo0	154	RA[1]	218	SD[9]
27	RTCOSCIN	91	PWM[0]	155	RA[2]	219	SD[6]
28	RTCOSCOUT	92	PWM[1]	156	RA[3]	220	SD[10]
29	OSCIN	93	PORTE[23]	157	RA[4]	221	SD[5]
30	OSCOUT	94	PORTE[22]	158	RA[5]	222	SD[11]
31	uVSSi0	95	uVSSi1	159	uVDDi2	223	uVSSo9
32	TESTSCAN	96	MMCCMD	160	SCAN_EN	224	SD[4]
33	uVDDi0	97	uVDDi1	161	uVSSi2	225	uVDDo9
34	AVDDUSB	98	MMCDAT	162	RA[6]	226	SD[12]
35	AUSBP	99	nMMCCD	163	RA[7]	227	uVDDi3
36	AUSBN	100	MMCCLK	164	uVSSo4	228	SD[3]
37	AVSSUSB	101	nDMAREQ	165	RA[8]	229	uVSSi3
38	PLLVD[1]	102	nDMAACK	166	uVDDo4	230	SD[13]
39	PLLFILT[1]	103	nRCS[3]	167	RA[9]	231	SD[2]
40	PLLVD[1]	104	nRCS[2]	168	RA[10]	232	SD[14]
41	PLLFILT[2]	105	nRCS[1]	169	RA[11]	233	SD[1]
42	PLLVD[0]	106	nRCS[0]	170	RA[12]	234	SD[15]
43	PLLFILT[0]	107	BOOTBIT[1]	171	RA[13]	235	SD[0]
44	PLLVD[0]	108	BOOTBIT[0]	172	RA[14]	236	uVSSo10
45	AVDDDAC	109	nROE	173	RA[15]	237	LLP
46	ADACR	110	EXPRDY	174	RA[16]	238	uVDDo10
47	ADACL	111	nRWE[3]	175	RA[17]	239	LAC
48	AVSSDAC	112	nRWE[2]	176	RA[18]	240	LBLEN
49	AVDDADC	113	uVSSo1	177	RA[19]	241	LCP
50	AVREFADC	114	nRWE[1]	178	RA[20]	242	LFP
51	ADIN[0]	115	uVDDo1	179	RA[21]	243	LCDEN
52	ADIN[1]	116	nRWE[0]	180	RA[22]	244	LD[15]
53	ADIN[2]	117	RD[31]	181	uVSSo5	245	LD[14]
54	ADIN[3]	118	RD[30]	182	RA[23]	246	LD[13]
55	ADIN[4]	119	RD[29]	183	uVDDo5	247	LD[12]
56	AVSSADC	120	RD[28]	184	RA[24]	248	LD[11]
57	ATSXP	121	RD[27]	185	SA[3]	249	LD[10]
58	ATSXN	122	RD[26]	186	SA[4]	250	LD[9]
59	ATSYP	123	RD[25]	187	SA[2]	251	LD[8]
60	ATSYN	124	RD[24]	188	SA[5]	252	LD[7]
61	nPMWAKEUP	125	RD[23]	189	SA[1]	253	LD[6]
62	nPOR	126	RD[22]	190	SA[6]	254	uVSSo11
63	nRESET	127	uVSSo2	191	uVSSo6	255	LD[5]
64	PMADAPOK	128	RD[21]	192	SA[0]	256	uVDDo11

2.1.2 FBGA Type

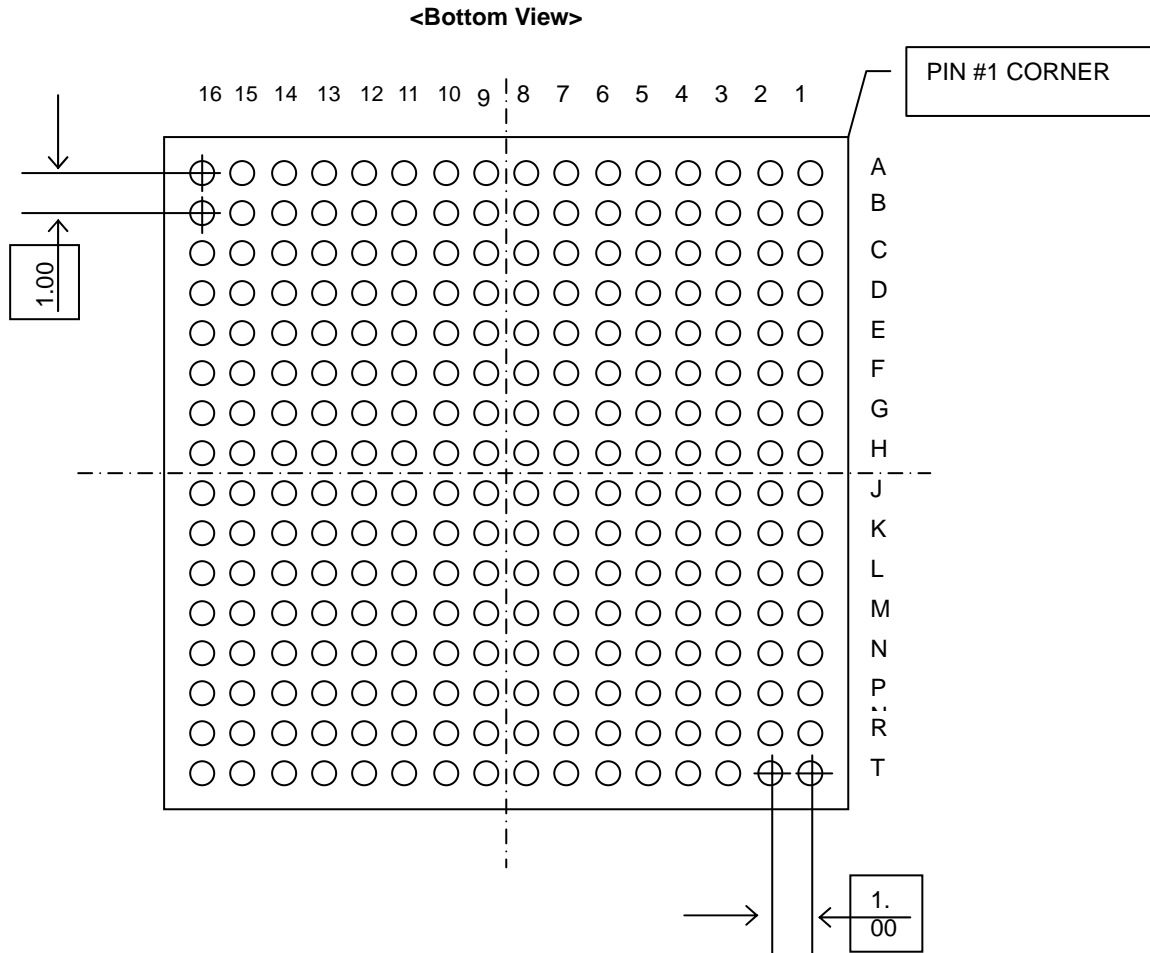

Body Size	Ball Count	Signal I/O	Package Height	Row Array	Ball Matrix	Ball Pitch
17.0X17.0	256	256	1.40	Full Array	16X16	1.00

Note : All dimensions in mm.

Pin No.	PAD Name	Pin No.	PAD Name	Pin No.	PAD Name	Pin No.	PAD Name
B1	LD[4]	T2	PMBATOK	R16	RD[20]	A15	uVDDo6
C2	LD[3]	R3	nPLLENABLE	P15	uVDDo2	B14	SA[7]
C1	LD[2]	T3	nTEST	P16	RD[19]	A14	SA[8]
D3	LD[1]	P4	nURING	N14	RD[18]	C13	SA[9]
D1	LD[0]	T4	nUDTR	N16	RD[17]	A13	SA[10]
D2	KSCANO[1]	R4	nUCTS	N15	RD[16]	B13	SA[11]
E4	KSCANO[2]	N5	nURTS	M13	RD[15]	D12	SA[12]
E1	KSCANO[0]	T5	nUDSR	M16	RD[14]	A12	SA[13]
E3	KSCANO[3]	P5	nUDCD	M14	RD[13]	C12	uVSSo7
E2	KSCANO[4]	R5	USIN[0]	M15	RD[12]	B12	SA[14]
F5	KSCANO[5]	M6	USOUT[0]	L12	RD[11]	E11	uVDDo7
F4	KSCANO[6]	N6	USIN[1]	L13	RD[10]	D11	nSCS[1]
F1	KSCANO[7]	T6	USOUT[1]	L16	RD[9]	A11	nSCS[0]
F3	KSCANI[0]	P6	PORTC[1]	L14	RD[8]	C11	nSRAS

F2	KSCANI[1]	R6	PORTC[2]	L15	RD[7]	B11	nSCAS
G6	KSCANI[2]	L7	PORTB[6]	K11	uVSSo3	F10	nSWE
G5	KSCANI[3]	M7	PORTB[7]	K12	RD[6]	E10	SCKE[1]
G4	KSCANI[4]	N7	PORTB[8]	K13	uVDDo3	D10	SCKE[0]
G1	KSCANI[5]	T7	PORTB[9]	K16	RD[5]	A10	SCLK
G3	KSCANI[6]	P7	PORTB[10]	K14	RD[4]	C10	SDQMU
G2	KSCANI[7]	R7	PORTB[11]	K15	RD[3]	B10	uVSSo8
H7	TDI	K8	TimerOut	J10	RD[2]	G9	SDQML
H6	TCK	L8	PSDAT	J11	RD[1]	F9	uVDDo8
H5	TMS	M8	uVSSo0	J12	RD[0]	E9	SD[8]
H4	nTRST	N8	PSCLK	J13	RA[0]	D9	SD[7]
H1	TDO	T8	uVDDo0	J16	RA[1]	A9	SD[9]
H3	RTCOSCIN	P8	PWM[0]	J14	RA[2]	C9	SD[6]
H2	RTCOSCOUT	R8	PWM[1]	J15	RA[3]	B9	SD[10]
J7	OSCIN	K9	PORTE[23]	H10	RA[4]	G8	SD[5]
J6	OSCOUT	L9	PORTE[22]	H11	RA[5]	F8	SD[11]
J5	uVSSi0	M9	uVSSi1	H12	uVDDi2	E8	uVSSo9
J4	TESTSCAN	N9	MMCCMD	H13	SCAN_EN	D8	SD[4]
J2	uVDDi0	R9	uVDDi1	H15	uVSSi2	B8	uVDDo9
J3	AVDDUSB	P9	MMCDAT	H14	RA[6]	C8	SD[12]
J1	AUSBP	T9	nMMCCD	H16	RA[7]	A8	uVDDi3
J8	AUSBN	J9	MMCCLK	H9	uVSSo4	H8	SD[3]
K5	AVSSUSB	M10	nDMAREQ	G12	RA[8]	E7	uVSSi3
K4	PLLVD[1]	N10	nDMAACK	G13	uVDDo4	D7	SD[13]
K2	PLLFILT[1]	R10	nRCS[3]	G15	RA[9]	B7	SD[2]
K3	PLLSS[1]	P10	nRCS[2]	G14	RA[10]	C7	SD[14]
K6	PLLFILT[2]	L10	nRCS[1]	G11	RA[11]	F7	SD[1]
K7	PLLVD[0]	K10	nRCS[0]	G10	RA[12]	G7	SD[15]
K1	PLLFILT[0]	T10	BOOTBIT[1]	G16	RA[13]	A7	SD[0]
L6	PLLSS[0]	L11	BOOTBIT[0]	F11	RA[14]	F6	uVSSo10
L2	AVDDDAC	R11	nROE	F15	RA[15]	B6	LLP
L4	ADACR	N11	EXPRDY	F13	RA[16]	D6	uVDDo10
L3	ADACL	P11	nRWE[3]	F14	RA[17]	C6	LAC
L5	AVSSDAC	M11	nRWE[2]	F12	RA[18]	E6	LBLEN
L1	AVDDADC	T11	uVSSo1	F16	RA[19]	A6	LCP
M4	AVREFADC	N12	nRWE[1]	E13	RA[20]	D5	LFP
M2	ADIN[0]	R12	uVDDo1	E15	RA[21]	B5	LCDEN
M5	ADIN[1]	M12	nRWE[0]	E12	RA[22]	E5	LD[15]
M3	ADIN[2]	P12	RD[31]	E14	uVSSo5	C5	LD[14]
M1	ADIN[3]	T12	RD[30]	E16	RA[23]	A5	LD[13]
N4	ADIN[4]	N13	RD[29]	D13	uVDDo5	D4	LD[12]
N2	AVSSADC	R13	RD[28]	D15	RA[24]	B4	LD[11]
N3	ATSXP	P13	RD[27]	D14	SA[3]	C4	LD[10]
N1	ATSXN	T13	RD[26]	D16	SA[4]	A4	LD[9]
P2	ATSYP	R14	RD[25]	C15	SA[2]	B3	LD[8]
P1	ATSYN	T14	RD[24]	C16	SA[5]	A3	LD[7]
P3	nPMWAKEUP	P14	RD[23]	C14	SA[1]	C3	LD[6]
R1	nPOR	T15	RD[22]	B16	SA[6]	A2	uVSSo11
R2	nRESET	R15	uVSSo2	B15	uVSSo6	B2	LD[5]
T1	PMADAPOK	T16	RD[21]	A16	SA[0]	A1	uVDDo11

2.2 Pin Descriptions

Table 2-2 describes the function of all the external signals to the HMS30C7202.

Type	Description	Type	Description
O	Output	OA	Analog Output
I	Input	IA	Analog Input
IO	Input/Output	IOA	Analog Input/Output
IS	Input with Schmitt level input threshold	P	Power input
U	Suffix to indicate integral pull-up	D	Suffix to indicate integral pull-down
m	Suffix to multiple function pin		

Table 2-1 Pin Signal Type Definition

2.2.1 External Signal Functions

Function	Signal Name	Signal Type	Description
LCD	LD[15:0]	Om	LCD data bus. Allow 5:6:5 TFT, color (using [7:0]) or mono, using [3:0] or [7:0]
	LCP	O	LCD clock pulse
	LLP	O	LCD line pulse (Hsync for TFT)
	LFP	O	LCD frame pulse (Vsync for TFT)
	LAC	O	LCD AC bias (clock enable for TFT)
	LCDEN	O	Display enable signal for LCD. Enables high voltage to LCD
	LBLEN	Om	LCD backlight enable
Static Memory Interface	RA[24:0]	O	ROM address bus
	RD[31:0]	IOm	ROM data bus
	nRCS[3:0]	Om	ROM chip select outputs
	nROE	O	ROM output enable signal
	nRWE[3:0]	Om	ROM write enable signals
	EXPRDY	I	Wait from external I/O
	BOOTBIT[1:0]	I	8/16/32 bit ROM selection
SDRAM Interface	SCLK	O	SDRAM clock output
	SCKE[1:0]	O	SDRAM clock enable output
	nSRAS	O	SDRAM RAS output
	nSCAS	O	SDRAM CAS output
	nSWE	O	SDRAM write enable output
	nSCS[1:0]	O	SDRAM chip select outputs
	SDQML	O	SDRAM lower data byte enable
	SDQMU	O	SDRAM upper data byte enable
	SD[15:0]	IO	SDRAM data bus
SA[14:0]	O	SDRAM address bus	
DMA Interface	nDMAREQ	Im	DMA request input (active Low)
	nDMAACK	Om	DMA acknowledge output
UART	nUDCD0	Im	UART data carrier detect input
	nUDSR0	Im	UART data set ready input
	nUCTS0	Im	UART clear to send input
	USIN[3:0]	Im	UART serial data inputs
	USOUT[3:0]	Om	UART serial data outputs
	nUDTR0	Om	UART data terminal ready
	nURTS0	Om	UART request to send
	nURING0	Im	UART ring input signal (wake-up signal to PMU)
IrDA	IRDIN1	Im	IrDA infra-red data input
	IRDOUT1	Om	IrDA infra-red data output
USB	AUSBP	AIO	USB positive signal
	AUSBN	AIO	USB negative signal

Function	Signal Name	Signal Type	Description
	AVDDUSB	P	USB analog Vdd
	AVSSUSB	P	USB analog Vss
PWM	PWM[1:0]	Om	Pulse width modulation output
	TIMEROUT	Om	Timer output
Matrix Keyboard	KSCANO[7:0]	Om	Matrix keyboard scan outputs
	KSCANI[7:0]	Im	Matrix keyboard scan inputs
PS/2 Interface	PS2D	ODm	PS2 data signal
	PS2CK	ODm	PS2 clock signal
MMC	SSDO	Om	MMC card controller data output
	SSDI	Im	MMC card controller data input
	SSCLK	Om	MMC card controller clock output
	nSSCS	Om	MMC card controller chip select
SSFDC (SmartCard)	SMD[7:0]	IOm	Smart Media Card (SSFDC) data signals
	nSMWP	Om	Smart Media Card (SSFDC) write protect
	nSMWE	Om	Smart Media Card (SSFDC) write enable
	SMALE	Om	Smart Media Card (SSFDC) address latch enable
	SMCLE	Om	Smart Media Card (SSFDC) command latch enable
	nSMCD	Im	Smart Media Card (SSFDC) card detection signal
	nSMCE	Om	Smart Media Card (SSFDC) chip enable
	nSMRE	Om	Smart Media Card (SSFDC) read enable
	nSMRB	Im	Smart Media Card (SSFDC) READY/nBUSY signal
ADC	ATSXP	IO	Touch screen switch X high drive
	ATSN	O	Touch screen switch X low drive
	ATSYP	IO	Touch screen switch Y high drive
	ATSYN	O	Touch screen switch Y low drive
	ADIN[4:0]	AI	ADC inputs for MIC, battery, touch
	AVDDADC	P	ADC analog Vdd
	AVSSADC	P	ADC analog Vss
	AVREFADC	AI	ADC reference voltage
DAC	AVDDDAC	P	DAC analog Vdd
	AVSSDAC	P	DAC analog Vss
	ADACR	AO	Sound DAC output (Right channel)
	ADACL	AO	Sound DAC output (Left channel)
PLL	PLLVD[1:0]	P	PLL analog Vdd
	PLLVS[1:0]	P	PLL analog Vss
	PLLFILT[2:0]	AI	External PLL loop filter input pins (1 per PLL)
GPIO	PORTA[15:0]	IOm	General purpose input/output signals
	PORTB[11:0]	IOm	General purpose input/output signals
	PORTC[10:0]	IOm	General purpose input/output signals
	PORTD[8:0]	IOm	General purpose input/output signals
	PORTE[24:0]	IOm	General purpose input/output signals
System	nPOR	IS	Power on reset input. Schmitt level input with pullup
	nPMWAKEUP	IS	Wake-up "on-key" input. Low causes PMU to exit standby state.
	nRESET	IO	Reset input (also driven out in POR, until the PLL is locked)
	PMADAPOK	I	Adapter power OK
	PMBATOK	I	Main battery OK
Oscillator	RTCOSCIN	I	RTC oscillator input
	RTCOSCOUT	O	RTC oscillator output
	OSCIN	I	Main oscillator input
	OSCOUT	O	Main oscillator output
Digital Power/Ground	VDDCore[3:0]	P	Core Vdd supply (2.5V)
	VSSCore[3:0]	P	Core Vss supply
	VDD[11:0]	P	IO Vdd supply (3.3V)
	VSS[11:0]	P	IO Vss supply

Function	Signal Name	Signal Type	Description
JTAG	TCK	Iu	JTAG boundary scan and debug test clock
	nTRST	Id	JTAG boundary scan and debug test reset
	TMS	Iu	JTAG boundary scan and debug test mode select
	TDI	Iu	JTAG boundary scan and debug test data input
	TDO	O	JTAG boundary scan and debug test data output
Test	nPLEENABLE	Id	Low to enable PLL. High to bypass PLL with clock from OSCIN
	TESTSCAN	Id	Scan Test Mode Enable
	SCAN_EN	Id	Scan Chain Activated
	nTEST	Iu	Test mode select

Table 2-2 External Signal Functions

2.2.2 Multiple Function Pins

2.2.2.1 PORT A

Data Input/Output

Primary (nTEST nPLEENABLE) & ~AEN* & ~AMULSEL**		GPIO Enable (nTEST nPLEENABLE) & AEN & ~AMULSEL		MultiFunction Enable (nTEST nPLEENABLE) & ~AEN & AMULSEL		BOTH Enable (nTEST nPLEENABLE) & AEN & AMULSEL		Analog Test (~nTEST & ~nPLEENABLE)	
I	O	I	O	I	O	I	O	I	O
	KSCAN00	PORTA0	PORTA0		PORTA0	PORTA0	PORTA0	TPLL3FREQSEL[0]	
	KSCAN01	PORTA1	PORTA1		PORTA1	PORTA1	PORTA1	TPLL3FREQSEL[1]	
	KSCAN02	PORTA2	PORTA2		PORTA2	PORTA2	PORTA2	TPLL3FREQSEL[2]	
	KSCAN03	PORTA3	PORTA3			PORTA3	PORTA3	TPLL3FREQSEL[3]	
	KSCAN04	PORTA4	PORTA4			PORTA4	PORTA4	TPLL3FREQSEL[4]	
	KSCAN05	PORTA5	PORTA5	USIN2		PORTA5	PORTA5	TPLL3FREQSEL[5]	
	KSCAN06	PORTA6	PORTA6		USOUT2	PORTA6	PORTA6	TPLL3PWDN	
	KSCAN07	PORTA7	PORTA7		IRDOUT	PORTA7	PORTA7		TPLL3CLKOut
KSCAN10		PORTA8	PORTA8		PORTA8	PORTA8	PORTA8		TPLL3CLKQOut
KSCAN11		PORTA9	PORTA9		PORTA9	PORTA9	PORTA9		TPLL3LOCKOut
KSCAN12		PORTA10	PORTA10		PORTA10	PORTA10	PORTA10	TAIOSTOP	
KSCAN13		PORTA11	PORTA11			PORTA11	PORTA11	TACH[0]	
KSCAN14		PORTA12	PORTA12			PORTA12	PORTA12	TACH[1]	
KSCAN15		PORTA13	PORTA13	USIN3		PORTA13	PORTA13	TACH[2]	
KSCAN16		PORTA14	PORTA14		USOUT3	PORTA14	PORTA14	TACH[3]	
KSCAN17		PORTA15	PORTA15	IRDIN		PORTA15	PORTA15	TACH[4]	

* AEN : GPIO PORT A Enable Register (0x8002.301C).

** AMULSEL : GPIO PORT A Multi-Function Select Register (0x8002.30A4).

2.2.2.2 PORT B

Data Input/Output

Primary nTEST & ~nPLEENABLE & ~BEN*		GPIO Enable nTEST & ~nPLEENABLE & BEN		Normal Bypass nTEST & nPLEENABLE		Normal TEST ~nTEST & nPLEENABLE & ~BEN		UART TEST ~nTEST & nPLEENABLE & BEN		Analog Test ~nTEST & ~nPLEENABLE	
I	O	I	O	I	O	I	O	I	O	I	O
nURING		PORTB0	PORTB0	nURING		TBCLK		nURING			
	nUDTR	PORTB1	PORTB1		nUDTR	TBCLK			nUDTR		
nUCTS		PORTB2	PORTB2	nUCTS				nUCTS		TACK	
	nURTS	PORTB3	PORTB3		nURTS				nURTS		TAD[9]
nUDSR		PORTB4	PORTB4	nUDSR				nUDSR			TAD[8]
nUDCD		PORTB5	PORTB5	nUDCD				nUDCD			TAD[7]
PORTB6	PORTB6	PORTB6	PORTB6	TBCLK		TBCLK					
PORTB7	PORTB7	PORTB7	PORTB7	TBOFCLK		TBOFCLK					
PORTB8	PORTB8	PORTB8	PORTB8	TBCLK		TBCLK					
PORTB9	PORTB9	PORTB9	PORTB9				TACK		TACK		TACK
PORTB10	PORTB10	PORTB10	PORTB10	TBCLK		TREQB		TREQB		TREQB	
PORTB11	PORTB11	PORTB11	PORTB11	TBCLK		TREQA		TREQA		TREQA	

* BEN : GPIO PORT B Enable Register (0x8002.303C).

2.2.2.3 PORT C
Data Input/Output

Primary (nTEST nPllenable) & ~CEN*		GPIO Enable (nTEST nPllenable) & CEN		Analog Test ~nTEST & ~nPllenable	
I	O	I	O	I	O
	TIMEROUT	PORTC0	PORTC0		TAD[2]
PORTC1	PORTC1	PORTC1	PORTC1		TAD[4]
PORTC2	PORTC2	PORTC2	PORTC2		TAD[3]
PSDAT	PSDAT	PORTC3	PORTC3		TAD[1]
PSCLK	PSCLK	PORTC4	PORTC4		TAD[0]
	PWM0	PORTC5	PORTC5	TDIOSTOP	
	PWM1	PORTC6	PORTC6	TDLEFT	
nDMAREQ		PORTC7	PORTC7	TDD[2]	
	nDMAACK	PORTC8	PORTC8	TDD[1]	
	nRCS2 / [nRCS2dma]	PORTC9	PORTC9		
	nRCS3	PORTC10	PORTC10	TDD[0]	

* CEN : GPIO PORT C Enable Register (0x8002.305C).

2.2.2.4 PORT D
Data Input/Output

Primary (nTEST nPllenable) & ~DEN*		GPIO Enable (nTEST nPllenable) & DEN		Analog Test ~nTEST & ~nPllenable	
I	O	I	O	I	O
	LD8	PORTD0	PORTD0	TPLL1PVDN	
	LD9	PORTD1	PORTD1	TPLL1FREQSEL[0]	
	LD10	PORTD2	PORTD2	TPLL1FREQSEL[1]	
	LD11	PORTD3	PORTD3	TPLL1FREQSEL[2]	
	LD12	PORTD4	PORTD4	TPLL1FREQSEL[3]	
	LD13	PORTD5	PORTD5	TPLL1FREQSEL[4]	
	LD14	PORTD6	PORTD6	TPLL1FREQSEL[5]	
	LD15	PORTD7	PORTD7	TPLL1PCLKIn	
	LLEN	PORTD8	PORTD8		

● DEN : GPIO PORT D Enable Register (0x8002.307C).

**2.2.2.5 PORTE
Data Input/Output**

Primary (nTEST & -HalfWordSel & -EEN*1)		GPIO Enable (nTEST & EEN)		MultiFunction 1 (nTEST & HalfWordSel*3 & -EEN & -SWAP*2)		MultiFunction 2 (nTEST & HalfWordSel & -EEN & SWAP)		Test Mode (-nTEST)		Analog Test (-nTEST & -nPLENABLE)	
I	O	I	O	I	O	I	O	I	O	I	O
RD16	RD16	PORTE0	PORTE0		nUSBOE	SMD7	SMD7	RD16	RD16		
RD17	RD17	PORTE1	PORTE1		UVPO	SMD6	SMD6	RD17	RD17		
RD18	RD18	PORTE2	PORTE2		UVMO	SMD5	SMD5	RD18	RD18		
RD19	RD19	PORTE3	PORTE3		USUSPEND	SMD4	SMD4	RD19	RD19		
RD20	RD20	PORTE4	PORTE4	URCVIN		SMD3	SMD3	RD20	RD20		
RD21	RD21	PORTE5	PORTE5	UVM		SMD2	SMD2	RD21	RD21		
RD22	RD22	PORTE6	PORTE6	UVP		SMD1	SMD1	RD22	RD22		
RD23	RD23	PORTE7	PORTE7	SMD7	SMD7	SMD0	SMD0	RD23	RD23		
RD24	RD24	PORTE8	PORTE8	SMD6	SMD6		nSMWP	RD24	RD24		
RD25	RD25	PORTE9	PORTE9	SMD5	SMD5		nSMWE	RD25	RD25		
RD26	RD26	PORTE10	PORTE10	SMD4	SMD4		SMALE	RD26	RD26		
RD27	RD27	PORTE11	PORTE11	SMD3	SMD3		nSMRE	RD27	RD27		
RD28	RD28	PORTE12	PORTE12	SMD2	SMD2		nSMCE	RD28	RD28		
RD29	RD29	PORTE13	PORTE13	SMD1	SMD1	nSMCD		RD29	RD29		
RD30	RD30	PORTE14	PORTE14	SMD0	SMD0		SMCLE	RD30	RD30		
RD31	RD31	PORTE15	PORTE15		nSMWP	nSMRB		RD31	RD31		
	nRW2	PORTE16	PORTE16		nSMWE	Not use	Not use		PORTE16		
	nRW3	PORTE17	PORTE17		SMALE	Not use	Not Use		PORTE17		
MMCCMD / SSDI	MMCCMD/ ZERO	PORTE18	PORTE18		nSMRE		nUSBOE		PORTE18	TDD[6]	
MMCDAT	MMCDAT / SSDO	PORTE19	PORTE19		nSMCE		UVPO		PORTE19	TDD[5]	
nMMCCD	ZERO/ nSSCS	PORTE20	PORTE20	nSMCD			UVMO		PORTE20	TDD[4]	
	MMCCLK / SSCLK	PORTE21	PORTE21			SMCLE		USUSPEND		PORTE21	TDD[3]
PORTE22	PORTE22	PORTE22	PORTE22	nSMRB		URCVIN			PORTE22	TDD[7]	
PORTE23	PORTE23	PORTE23	PORTE23		PORTE23	UVM			PORTE23	TDRIGHT	
	RA24	PORTE24	PORTE24		RA24	UVP			RA24		

*1 EEN : GPIO PORT E Enable Register (0x8002.309C).

*2 SWAP : SWAP Pin Configuration Register (0x8002.30A8).

*3 When HalfWordSel is enable, MultiFunction 1 or 2 is usable instead of Primary RD16~31. To enable HalfWordSel , you should set bottom bits[1:0] of SMI Registers(MEMCFG0~3 on the Table 7-1) to [01 or 10 or 11].

Note : A 32 bit access is not possible without RD16~RD31.

So User should make program to disable PORTE for 32bit access time.

We are not guarantee that the program is alternated 32bit access(RD0~31) with PORTE.

2.2.2.6 USB Transceiver Test & Analog Test
Data Input/Output

nTEST &		~nTEST &			
Primary		~LCDEn & ~USBTransSel		& ~LCDEn & USBTransSel	
I	O	I	O	I	O
	LD0	TCANCK		TnUSBOE	
	LD1	TCANSM		TUVPO	
	LD2	TCANSI		TUVMO	
	LD3		TCANSO	TUSUSPEND	
	LD4				TURCVIN
	LD5				TUVM
	LD6				TUVP

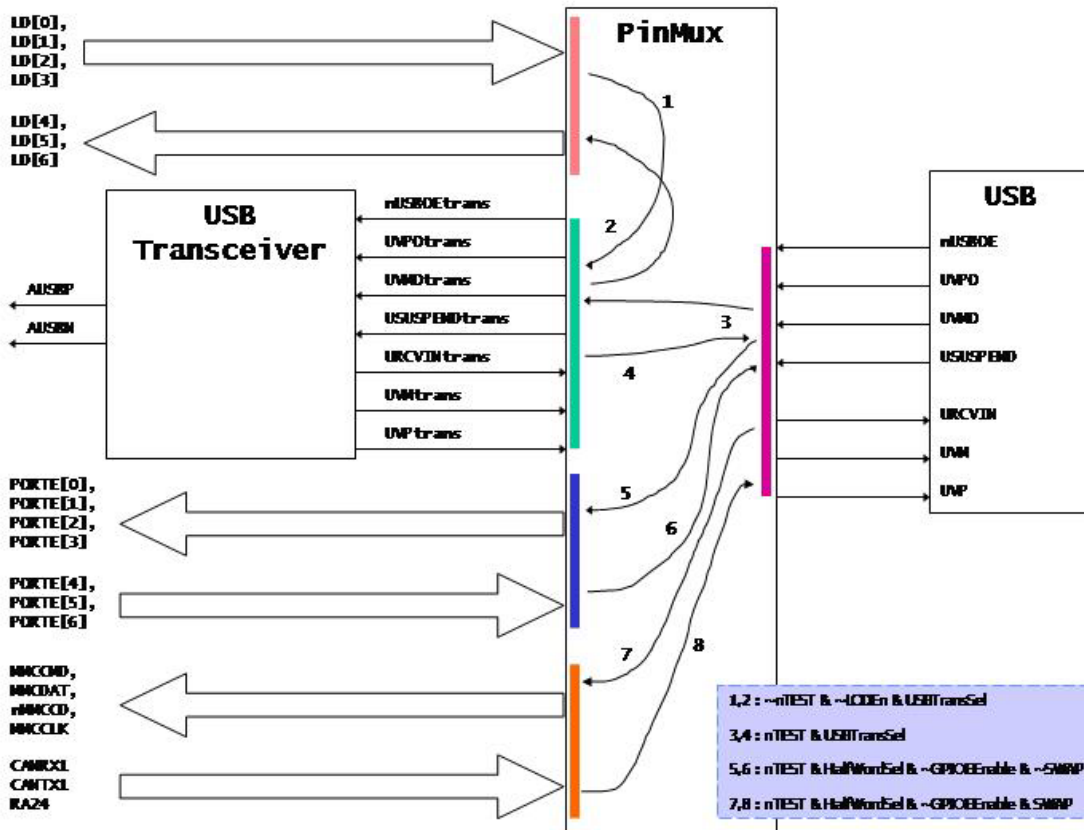

Figure USB Transceiver Test Scheme VER1.5

2.2.2.7 DMA
Data Input/Output

nTEST &			
nDMAACK		~nDMAACK	
I	O	I	O
	nROE		nROEdma
	nRWE0		nRWE0dma

2.2.2.8 Inverter Chain

When nTESTANA == 0, BOOTBIT1 → nRWE1 (total 50ns delay expected)

3 ARM720T MACROCELL

3.1 ARM720T Macrocell

For details of the ARM720T, please refer to the *ARM720T Data Sheet* (DDI 0087).

4 MEMORY MAP

There are five main memory map divisions, outlined in Table 4-1 Top-level address map

Base Address (Byte)	Base Address (Hex)	Size	Description
0 Mbyte	0x0000.0000	32Mbytes	ROM chip select 0
64 Mbytes	0x0400.0000	32Mbytes	ROM chip select 1
128 Mbytes	0x0800.0000	32Mbytes	ROM chip select 2
192 Mbytes	0x0C00.0000	32Mbytes	ROM chip select 3
256 Mbytes	0x1000.0000	256Mbytes	Reserved
512 Mbytes	0x2000.0000	512Mbytes	Reserved
1024 Mbytes	0x4000.0000	32Mbytes	SDRAM chip select 0
1056 Mbytes	0x4200.0000	32Mbytes	SDRAM chip select 1
1088 Mbytes	0x4400.0000		SDRAM mode register chip 0
1120 Mbytes	0x4600.0000		SDRAM mode register chip 1
1152 Mbytes	0x4800.0000	896Mbytes	Reserved
2048 Mbytes	0x8000.0000	336Kbytes	Peripherals

Table 4-1 Top-level address map

The ROM has an address space of 256Mbytes that is split equally between four external ROM chip select. Actual address range for each chip select is 32Mbytes with 25 external address signals.

There is a maximum of 64Mbytes of SDRAM space. Reading from the address space(over 0x4400.0000) above the SDRAM address space(0x4000.0000~0x43ff.ffff) sets the mode registers in the SDRAM (**To set the SDRAM mode register, read operation from the ranges of SDRAM mode register is needed. For more information, refer 6.3.).**

The peripheral address space is subdivided into three main areas: those on the ASB, the fast APB and the slow APB. The base address for the peripherals is given in Table 3-2: Peripherals base addresses.

Function	Base Address (Hex)	Name	Description
ASB Peripherals	0x7F00.0000	IntSRAM Base	Internal SRAM
	0x7F00.0800	Reserved	~0x7FFF.FFFF
	0x8000.0000	SDRAMC Base	SDRAM Controller
	0x8000.1000	PMU Base	PMU/PLL
	0x8000.2000	Reserved	
	0x8000.3000	BUSC Base	Bus controller
	0x8000.4000	DMAC Base	DMAC
Fast APB Peripherals	0x8000.5000	Reserved	~0x8000.FFFF
	0x8001.0000	LCD	LCD
	0x8001.1000	Reserved	
	0x8001.2000	USB Base	USB
	0x8001.3000	Sound Base	SOUND
	0x8001.4000	Reserved	
	0x8001.5000	MMC Base	MMC/ SPI
Slow APB Peripherals	0x8001.6000	SMC Base	SMC
	0x8001.7000	Reserved	~0x8001.FFFF
	0x8002.0000	U0 Base	UART 0
	0x8002.1000	U1 Base	UART 1 (support SIR)
	0x8002.2000	KBD Base	KBD
	0x8002.3000	GPIO Base	GPIO
	0x8002.4000	INTC Base	INTC
	0x8002.5000	Timer Base	TIMER
	0x8002.6000	Reserved	~0x8002.7FFF
	0x8002.8000	RTC Base	RTC
	0x8002.9000	ADC Base	ADC
0x8002.A000	Reserved		
0x8002.B000	WDT Base	WDT	

Function	Base Address (Hex)	Name	Description
	0x8002.C000	PS2 Base	PS2
	0x8002.D000	U2 Base	UART2
	0x8002.E000	U3 Base	UART3
	0x8002.F000	Reserved	
	0x8003.0000	Reserved	
	0x8003.1000	Reserved	~0x8004.FFFF

Table 4-2 Peripherals Base Addresses

5 PMU & PLL

The HMS30C7202 is designed primarily for HPC and other portable computing applications. Therefore there are 4 operating modes to reduce power consumption and extend battery life.

- RUN - normal operation (used for CPU-intensive tasks)
- SLOW - half-speed operation used when the application interacts with a user (e.g. word processing)
- IDLE - where the CPU operation is halted but peripherals operation continue (such as screen refresh, or serial communications)
- SLEEP & DEEP SLEEP - This mode will be perceived as 'OFF' by the user, but the SDRAM contents is maintained and only the real-time clock is running.

The transition between these modes is controlled by the PMU (see also 7.3 Power management states, page 7-5). The PMU is an ASB slave unit to allow the CPU to write to its control registers, and is an ASB master unit to provide the mechanism for stopping the ARM core's internal clock.

5.1 Block Functions

CLOCK generator

The CLOCK generator module controls the PLLs and gating clocks while the PLL outputs are unknown and to ensure that clocks are available during test modes and during RESET sequences.

FCLK (ARM Processor and SDRAM controller clock)

Derived from PLL3, programmable between 49.7664 MHz and 82.944 MHz by a 6-bit register (default frequency is 70.0416 MHz).

There are two methods for updating frequency, depending upon the state of bit 6 of the Clock Control register ClkCtl (see ClkCtl register on page 7-11). If bit 6 is set, then any data written to bits [5:0] of the ClkCtl register are immediately transferred to the pins of PLL3, thus causing the loop to unlock and to mute FCLK. This is only a safe mode of operation if PLL3 frequency and mark-space ratio is guaranteed to be within limits immediately after the Lock Detect signal has become active. If bit 6 is NOT set, then the HMS30C7202 must enter DEEP sleep mode before bits [5:0] of the Clock Control register are transferred to PLL3.

To switch between the two frequencies when bit 6 is not set:

- Software writes the new value into the ClkCtl register
- Set a Real Time Clock Alarm to wake the HMS30C7202 in 2 seconds
- Enter DEEP SLEEP Mode by writing to the PMU Mode Register
- The HMS30C7202 will power up with PLL3 running at the new frequency

BCLK

Bus Clock is generated by the PMU by dividing FCLK by 2.

VCLK

VCLK is generated by PLL1 and clocks the LCD controller. The frequency is selectable between 24.8832MHz or 41.472MHz (default is 30.4128 MHz). The VCLK PLL is disabled when on BnRES is active or when the PMU is put into DEEP SLEEP mode. On exit from either of these conditions, the VCLK PLL must be re-enabled by software.

Changing Frequency:

1. Software must first disable the VCLK pll, by writing a '0' to the PLL1Enable bit of the ClkCtl register.
2. Write the new value to the PLL1Freq bit.
3. Re-enable the VCLK pll by writing 1 to the PLL1Enable bit.

CCLK

CCLK is generated by PLL2 and clocks the USB block - Nominally 48MHz. The CCLK PLL is disabled when BnRES active or when the PMU is put into DEEP SLEEP mode. On exit from either of these conditions, the CCLK PLL must be re-enabled by software.

PMU state machine

The state machine handles the transition between the power management states described below. The CPU

can write to the PMU mode registers (which is what would typically happens when a user switches off the device) and the state machine will proceed to the commanded state.

5.2 Power management

5.2.1 State Diagram

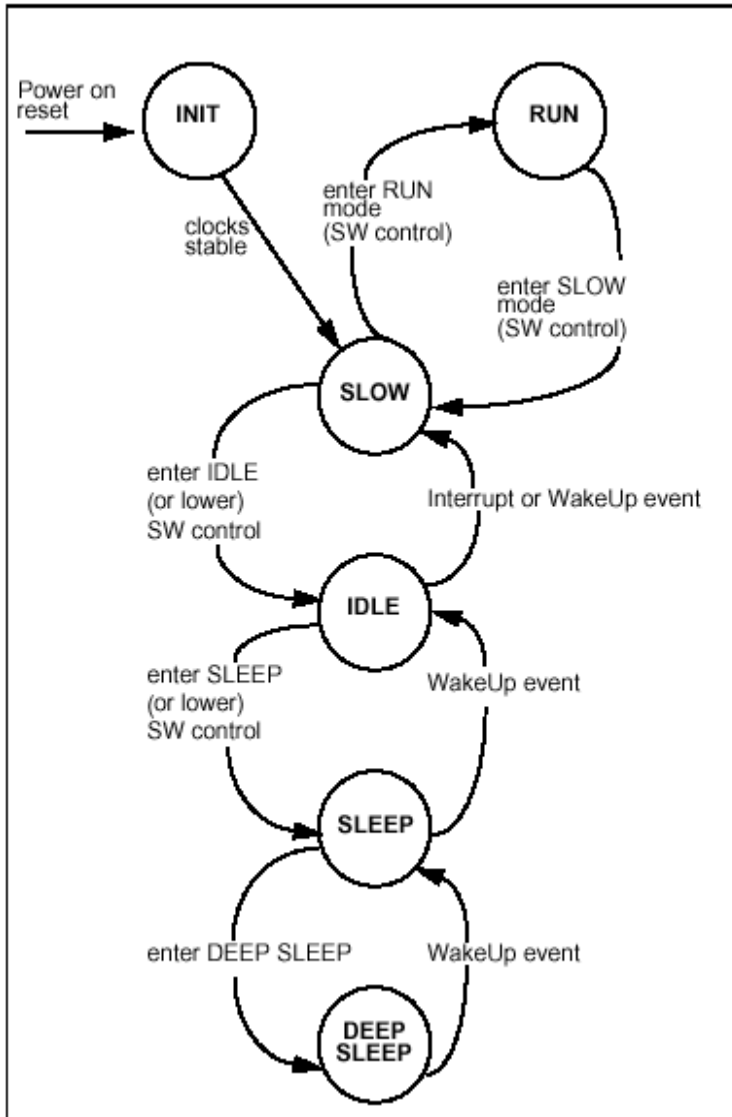

Figure 5-1 PMU Power Management State Diagram

5.2.2 Power management states

RUN

The system is running normally. All Clocks running (except where gated locally). The SDRAM controller is performing normal refresh.

SLOW

The CPU is switched into FastBus mode, and hence runs at the BCLK rate (half the FCLK rate). This is the default mode after exiting SLEEP Mode.

IDLE

In this mode, the PMU becomes the bus master until there is either a fast or normal interrupt for the CPU, or the peripheral DMA controller requests master-ship of the bus.

This will cause the clocks in the CPU to stop when it attempts an ASB access. This mode can be initiated by writing the PMU_IDLE value to the PMU Mode Register (in RUN or SLOW mode), or by a WakeUp signal while the CPU is in SLEEP or DEEP SLEEP mode.

SLEEP

In this mode, the SDRAM is put into self-refresh mode, and internal clocks are gated off. This mode can only be entered from IDLE mode (the PMU bus master must have mastership of the ASB before this mode can be entered). The PMU must be bus master to ensure that the system is stopped in a safe state, and is not half way through a SDRAM write (for example). Both the Video and Communication clocks should be disabled before entering this state.

Usually this state would only be entered briefly, on the way to entering DEEP SLEEP mode.

DEEP SLEEP

In DEEP SLEEP mode, the 3.6864MHz oscillator and the PLL are disabled. This is the lowest power state available. Only the 32 kHz oscillator runs, driving the real time clock and the PMU. Clocked circuitry in the PMU runs at 4kHz (i.e. the RTC clock divided by 8). Everything else is powered down, and SDRAM is in self refresh mode. This is the normal system "off" mode.

SLEEP and DEEP SLEEP modes are exited either by a user wake-up event (generally pressing the "On" key), or by an RTC wake-up alarm, or by a modem ring indicate event. These interrupt sources go directly to the PMU.

5.2.3 Wake-up Debounce and Interrupt

The Wake-up events are debounced as follows:

Each of the event signals which are liable to noise (nRESET, RTC, nPMWAKEUP, and Modem Ring Indicator, Power Adapter Condition) is re-timed to a 250 Hz clock derived from the low power (4 kHz) clock. After filtering to a quarter of 250 Hz, each event has an associated 'sticky' register bit. nPMWAKEUP is an external input, which may be typically connected to an "ON" key.

A 'sticky' bit is a register bit that is set by the incoming event, but is only reset by the CPU. Thus should a PLL drop out of lock momentarily (for example) the CPU will be informed of the event, even if the PLL has regained lock by the time the CPU can read its associated register bit.

The nPMWAKEUP, Modem, Real Time Clock, HotSync(GPIOB[10]) and Power Adapter condition inputs are combined to form the PMU Interrupt. Each of these four interrupt sources can wake up from deep-sleep mode individually and all wake-up operation can not mask able. But when wake-up occur, user can mask interrupt signal to inform interrupt controller.

To make use of the nPMWAKEUP Interrupt, (for example) controlling software will need to complete the following tasks:

- Enable the nPMWAKEUP interrupt bit, by writing 1 to bit[11] of the Reset / Status register (PMUSTAT register).
- Once an interrupt has occurred, read the RESET / Status register to identify the source(s) of interrupt. In the case of a nPMWAKEUP event, the register will return 0x10.
- Clear the appropriate 'sticky' bit by writing a 1 to the appropriate location (in the nPMWAKEUP case, this will be 0x10.).

But Even though the nPMWAKEUP interrupt mask bit is masked, by writing 0 to bit[11] of the Reset Status register, chip shall wake-up with nPMWAKEUP signal.

PORTB[10] (HotSync) Wake-up Sequence

The HotSync interrupt is OR gated with nPMWAKEUP to support additional wake up sources.

HotSync input signal can be used as a wake up source; they are enabled using the Interrupt MASK Register. After wake up, s/w should program the PORTB Interrupt Mask Register and/or the PMU ResetStatus Register.

One other possible application is to use the nDCD signal, from the UART interface, as a wake up source, by connecting nDCD to a PORTB input. In Deep Sleep mode, nDCD can wake up the system by generating a PORTB interrupt request to the PMU block. The PMU state machine then returns the system to the operational mode.

5.3 Registers

Address	Name	Width	Default	Description
0x8000.1000	PMUMODE	4		PMU Mode Register
0x8000.1010	PMUID	32		PMU ID Register
0x8000.1020	PMUSTAT	17		PMU Reset/PLL Status Register
0x8000.1028	PMUCLK	16	0x1B	PMU Clock Control Register
0x8000.1030	PMUDBCT	9		PMU Debounce Test Register
0x8000.1038	PUMPLLTR	21		PMU PLL Test Register

Table 5-1 PMU Register Summary

5.3.1 PMU Mode Register (PMUMODE)

This read/write register is to change from RUN mode or SLOW mode into a different mode. The encoding is shown below, in PMU Mode encoding. The register can only be accessed in RUN mode or SLOW mode (these are the only modes in which the processor is active). Therefore, the processor will never be able to read values for modes other than mode 0x00 and mode 0x 01. A test controller may read other values as long as clocks are enabled with bit 8 of the PMU Debounce Counter Test Register. For more information, please refer 5.3.6.

				0x80001000				
31	...	3	2	1	0			
			WAKEUP	MODE SEL				
Bits	Type	Function						
31:4	-	Reserved						
3	R/W	Writing a `1` to this bit allows PMU to exit DEEP SLEEP mode when pins PMBATOK and PMADAPOK are both low. Writing a `0` to this bit prevents the PMU from leaving DEEP SLEEP mode when PMBATOK and PMADAPOK are both low						
2:0	R/W	Value	PMU Mode encoding					
		0x04	Initialization mode					
		0x01	RUN mode					
		0x00	SLOW mode					
		0x02	IDLE mode					
		0x03	SLEEP mode					
		0x07	DEEP SLEEP mode					

Note: All other values in the above table are undefined.

5.3.2 PMU ID Register (PMUID)

This read-only register returns a unique chip revision ID. Revision 0 of the HMS30C7202 device (the first revision) will return the constant value 0x00720200.

				0x80001010			
31	...					0	
0x00720200							

5.3.3 PMU Reset /PLL Status Register (PMUSTAT)

This read/write register provides status information on power on reset and the PLL status. The allocation is shown in following two tables: ResetStatus Register Bits. The bits in this register are `sticky` bits. For a definition of a sticky bit, please refer to 5.2.3 Wake-up Debounce and Interrupt. Generally, this register will be

read each time the ARM exits reset mode, so that the ARM can identify what event has caused it to exit from reset mode.

0x80001020

							16
							WARM RESET
15	14	13	12	11	10	9	8
HOTSYNC INTR	ADAPTOR INTR	RTC INTR	MRING INTR	WAKEUP INTR	HOTSYNC STATUS	WDT RST	WARM RST STATUS
7	6	5	4	3	2	1	0
ADAPTOR STATUS	RTC STATUS	MRING STATUS	WAKEUP STATUS	PLL3 LOCK	PLL2 LOCK	PLL1 LOCK	POR STATUS

Bits	Type	Function
31:17	-	Reserved
16	W	Warm RESET. Writing a `1' causes nRESET to be asserted. Writing `0' has no effect.
15	R/W	HOTSYNC interrupt Mask. When reads, 0 = Disable Hotsync interrupt from External pin. 1 = Enable Hotsync interrupt from External pin.
14	R/W	No External Power Interrupt Mask. When reads, 0 = Disable PMU interrupt from PMADAPOK LOW. 1 = Enable PMU interrupt from PMADAPOK LOW.
13	R/W	RTCEvt Interrupt Mask. When reads, 0 = Disable PMU interrupt from RTC 1 = Enable PMU interrupt from RTC
12	R/W	RIEvt Interrupt MASK PMU Interrupt Request / Clear When reads, 0 = Disable PMU interrupt from MRING 1 = Enable PMU interrupt from MRING
11	R/W	OnEvt Interrupt MASK PMU Interrupt Enable When reads, 0 = Disable PMU interrupt from nPMWAKEUP 1 = Enable PMU interrupt from nPMWAKEUP
10	R/w	HOTSYNC Event When reads, 0 = Not Hot Sync state; 1 = Hot Sync status When writes, HotSync Interrupt Clear. Writing a `1' to this bit clears the event bit
9	R/w	WDTEvt: Watch Dog Reset (Warm reset) When reads, 0 = No Watch dog Timer event occurred 1 = A Watch dog timer event has occurred since last cleared When writes, Watch dog Reset Clear. Writing a `1' to this bit clears the event bit
8	R/w	RESETEvt: Warm RESET Event (debounced) When reads, 0 = No Warm RESET event has occurred 1 = A Warm RESET event has occurred since last cleared When writes, Warm Reset Clear. Writing a `1' to this bit clears the event bit.
7	R/w	PowerFailEvt: ADPATOR NOT OK (debounced) When reads, 0 = No Power Fail event since last cleared 1 = A Power Fail event has occurred since last cleared When writes, Power Fail Interrupt Clear. Writing a `1' to this bit clears a pending interrupt bit.
6	R/w	RTCEvt When reads, 0 = No Real Time Clock (RTC) calendar wake-up event since last cleared 1 = Real Time Clock (RTC) calendar wake-up event since last cleared When writes, RTC Interrupt Clear. Writing a `1' to this bit clears a pending interrupt bit.
5	R/w	RIEvt (debounced) When reads, 0 = No Modem Ring Indicate wake-up event since last cleared 1 = Modem Ring Indicate wake-up event since last cleared When writes, RI Interrupt Clear. Writing a `1' to this bit clears a pending interrupt bit.

4	R/w	OnEvt (debounced) When reads, 0 = No On key event since last cleared; 1 = On key event since last cleared When writes, OnEvt Interrupt Clear. Writing a `1` to this bit clears a pending interrupt bit.
3	R/w	PLLLock3 When reads, 0 = System PLL has been locked since last cleared 1 = System PLL has fallen out of lock since last cleared When writes, writing a `1` to this bit causes the PLL3 Unlock event flag to be cleared.
2	R/w	PLLLock2 When reads, 0 = Comms PLL has been locked since last cleared 1 = Comms PLL has fallen out of lock since last cleared When writes, writing a `1` to this bit causes the PLL2 Unlock event flag to be cleared.
1	R/w	PLLLock1 When reads, 0= LCD PLL has been locked since last cleared 1= LCD PLL has fallen out of lock since last cleared When writes, writing a `1` to this bit causes the PLL1 Unlock event flag to be cleared.
0	R/w	PORStatus When reads, 0 = No POR since last cleared; 1 = POR since last cleared When writes, writing a `1` to this bit causes the nPOR event flag to be cleared.

5.3.4 PMU Clock Control Register (PMUCLK)

This register is used to control the frequency of PLL3, the system clock PLL and PLL1, the LCD clock. Six bits are defined which control the frequency of FCLK, and a further bit is used to control the frequency of PLL1, the LCD clock. The Default (Power on Reset) value for this register is 0x2126.

0x80001028

15	14	13	12	11	10	9	8
PLL2 ENABLE	PLL1 ENABLE	PLL1 FREQ					
7	6	5	4	3	2	1	0
PLL3 MUTE	PLL3 FREQ UPDATE	PLL3 FREQ					

Bits	Type	Function																																
31:16	-	Reserved																																
15	R/W	Set for PLL2 enable. Output will be gated until PLL2 Lock Detect (LD) is received. Reset for disable PLL2																																
14	R/W	Set for PLL1 enable. Output will be gated until PLL1 Lock Detect (LD) is received. Reset for disable PLL1																																
13:8	R/W	Same with bit [5:0]. But output clock frequency will be half of PLL3 – default 30.4128 MHz																																
7	R/W	Reset: PLL3 is muted when Lock detect = 0 (default) Set: PLL3 only muted after nPOR or nRESET. Subsequent unlock condition does not mute the clock. Allows dynamic changes to the clock frequency without halting execution. Care: this only will be legal if PLL3 is under-damped (i.e. will not exhibit overshoot in its lock behavior).																																
6	R/W	Reset: PLL3 frequency control frequency is only updated when PMU exits DEEP SLEEP mode (default) Set: PLL3 frequency control frequency is updated instantaneously																																
5:0	R/W	<table border="1"> <thead> <tr> <th>Value</th> <th>Frequency</th> <th>Value</th> <th>Frequency</th> </tr> </thead> <tbody> <tr> <td>0x1B</td> <td>49.7664 MHz</td> <td>0x25</td> <td>68.1984 MHz</td> </tr> <tr> <td>0x1C</td> <td>51.6096 MHz</td> <td>0x26</td> <td>70.0416 MHz - default</td> </tr> <tr> <td>0x1D</td> <td>53.4528 MHz</td> <td>0x27</td> <td>71.8848 MHz</td> </tr> <tr> <td>0x1E</td> <td>55.2960 MHz</td> <td>0x28</td> <td>73.7280 MHz</td> </tr> <tr> <td>0x1F</td> <td>57.1392 MHz</td> <td>0x29</td> <td>75.5712 MHz</td> </tr> <tr> <td>0x20</td> <td>58.9824 MHz</td> <td>0x2A</td> <td>77.4144 MHz</td> </tr> <tr> <td>0x21</td> <td>60.8256 MHz</td> <td>0x2B</td> <td>79.2576 MHz</td> </tr> </tbody> </table>	Value	Frequency	Value	Frequency	0x1B	49.7664 MHz	0x25	68.1984 MHz	0x1C	51.6096 MHz	0x26	70.0416 MHz - default	0x1D	53.4528 MHz	0x27	71.8848 MHz	0x1E	55.2960 MHz	0x28	73.7280 MHz	0x1F	57.1392 MHz	0x29	75.5712 MHz	0x20	58.9824 MHz	0x2A	77.4144 MHz	0x21	60.8256 MHz	0x2B	79.2576 MHz
Value	Frequency	Value	Frequency																															
0x1B	49.7664 MHz	0x25	68.1984 MHz																															
0x1C	51.6096 MHz	0x26	70.0416 MHz - default																															
0x1D	53.4528 MHz	0x27	71.8848 MHz																															
0x1E	55.2960 MHz	0x28	73.7280 MHz																															
0x1F	57.1392 MHz	0x29	75.5712 MHz																															
0x20	58.9824 MHz	0x2A	77.4144 MHz																															
0x21	60.8256 MHz	0x2B	79.2576 MHz																															

0x22	62.6688 MHz	0x2c	81.1008 MHz
0x23	64.5120 MHz	0x2D	82.9440 MHz
0x24	66.3552 MHz	Other values	Reserved

IF BIT 6 is `0`

When the CPU writes to bits 5:0 of this register, these bits are stored in a temporary buffer, which is not transferred to the PLL until the next time the PLL lock signal becomes inactive. This means that for a new value to take effect, it is necessary for the device to enter DEEP SLEEP mode first.

IF BIT 6 is `1`

The first effect that writing a new value to bits [5:0] will have is that PLL3 will go out of lock, and the Clock control circuit will immediately inhibit FCLK and BCLK, without first verifying that SDRAM operations have completed.

5.3.5 PMU Debounce Counter Test Register (PMUDBCT)

			0x80001030
Bits	Type	Function	
		Read	Write
31:9	-	Reserved	
8	W	Reset: Normal operation Set: Forces FCLK and BCLK to be active in all PMU states (test purposes only)	
7:6	-	Reserved	
5	R	Selected debounce counter bits	Reserved
4	R/W		Reset: normal operation Set: disables Bus Request from the PMU to allow CPU to read state machine for test purposes during PMU IDLE state.
3	R/W	Prescaler bits	Reset: nTEST takes value from input pin Set: forces local test mode
2:0	R/W		Select Debounce counter for Value Function
			0x0 nPMWAKEUP
			0x1 RING event
			0x3 Power Adapter event
			0x4 Warm Reset

In order that the debounce counters (which would normally be clocked at 4 kHz) may be independently exercised and observed, the counters may be triggered and observed using the above registers. **These registers are for testing only and are not required in normal use.**

5.3.6 PMU PLL Test Register (PMUPLLTR)

								0x80001038
31	...	21	20	19	18	17	16	
Reserved			Select LCLK, CCLK	Select BCLK	Select PLL Test 01(PLL1), 10(PLL2), 11(PLL3)		PLL TEST MUX	
15	14	13	12	11	10	9	8	
PMUTEST	PWRDN1	PWRDN2	PWRDN3	PLL1 Frequency				
7	6	5	4	3	2	1	0	
PLL3 Frequency								
Bits	Type	Function						
31:21	-	Reserved						
20								
19								

18:17
16
15
14
13
12
11:6
5:0

5.4 Timings

5.4.1 Reset Sequences of Power On Reset

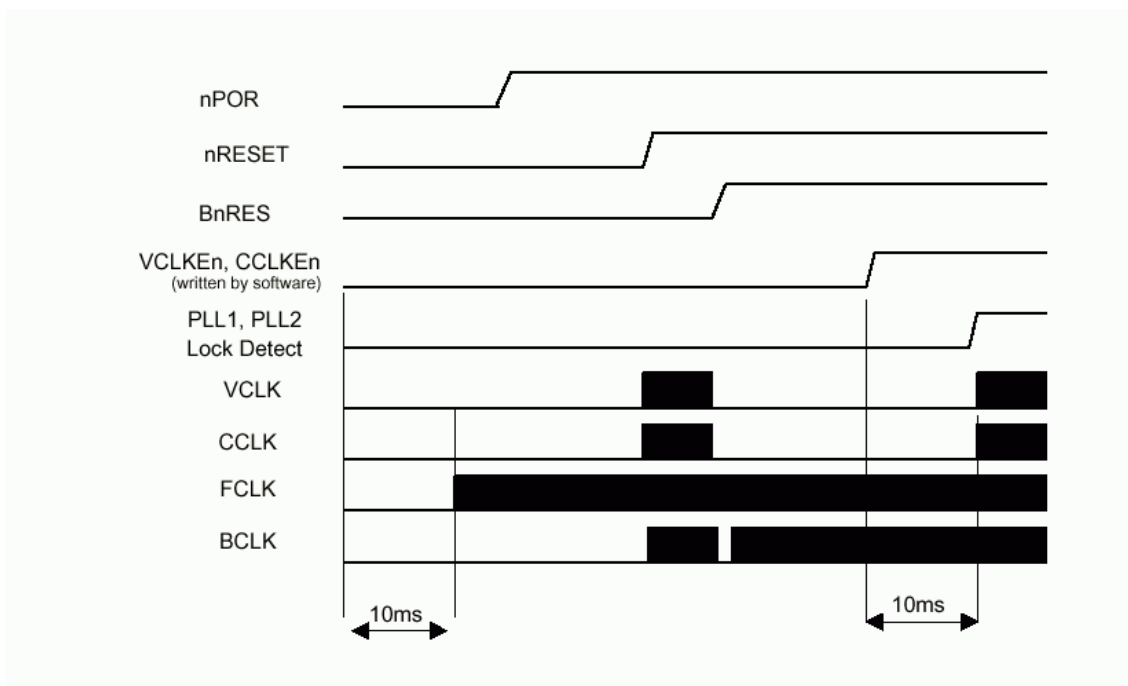

Figure 5-2 PMU Cold Reset Event

In the event of removal and re-application of all power to the HMS30C7202, the following sequence may be typical:

- nPOR input is active. All internal registers are reset to their default values. The PMU drives nRESETout LOW to reset any off-chip peripheral devices.
- BnRES becomes active on exit from the nPOR condition. Clocks are enabled temporarily to allow synchronous resets to operate.
- The default frequency of FCLK on exit from nPOR will be 70.0416 MHz.
- When FCLK is stable, the CPU clock is released. If the CPU were to read the RESET/Status register at this time, it will return 0x10f as a initial value.
- If you are to clear these flag bits, write 0x10f to the RESET register. (Refer 5.3.4 PMU Reset/PLL Status Register).
- The CPU writes 0x20 to the clock control register, which will set a FCLK speed of 58.9824MHz. The new clock frequency, however, is not adopted until the
- PMU has entered and left DEEP SLEEP mode.
- The CPU sets a RTC timer alarm to expire in approximately 2 seconds
- The CPU sets DEEP SLEEP into the PMU Mode Register
- The PMU state machine will enter DEEP SLEEP mode (via the intermediate states shown in Figure 5-1: Power Management State Diagram).
- When the RTC timer alarm is activated, the PMU automatically wakes up into SLOW mode, but with the new FCLK

frequency of 58.9824Mhz.

- The CPU may write 0xE120 to the Clock Control register, which enables CCLK and VCLK, and retains the new FCLK frequency.

Bit	Meaning
Bit 0 set:	Power On Reset event has occurred
Bit 1 set:	PLL1 has been `unlocked'
Bit 2 set:	PLL2 has been `unlocked'
Bit 3 set:	PLL3 has been `unlocked'

Table 5-2 PMU Bit Settings for a cold Reset Event within PMUSTAT Register

5.4.2 Software Generated Warm Reset

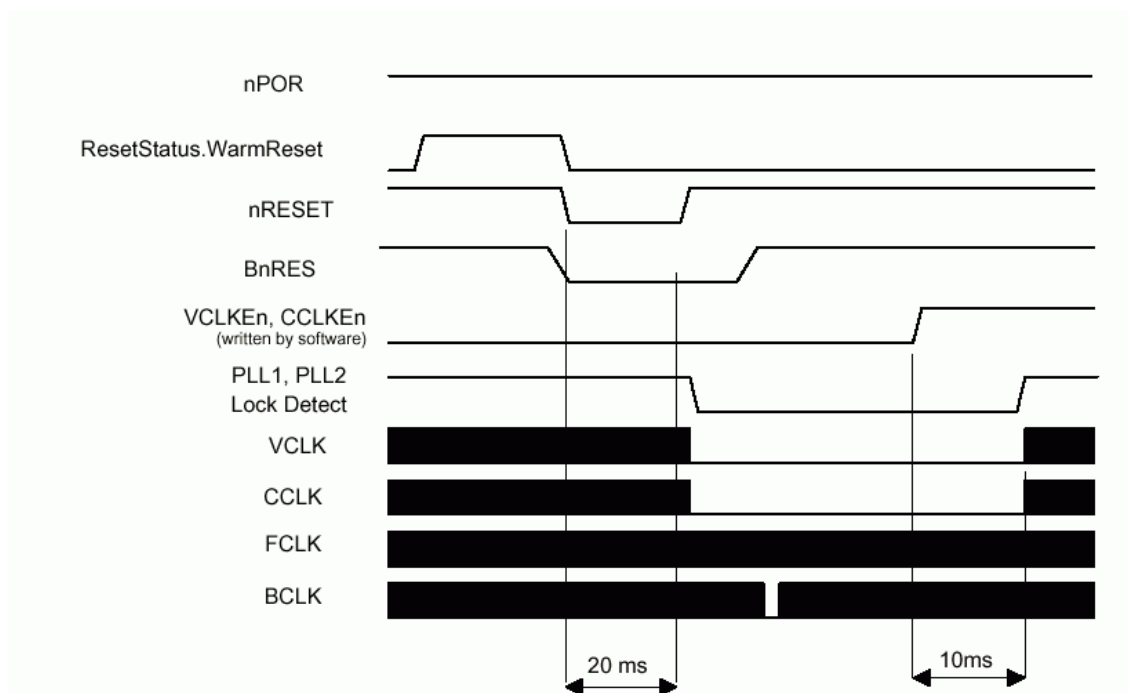

Figure 5-3 PMU Software Generated Warm Reset

The CPU writes `1' to the WarmReset bit of PMUSTAT register. The PMU drives nRESET low. The internal chip reset, BnRES is driven low. The PMU detects that the bi-directional nRESET pin is low. nRESET is filtered by a de-bounce circuit. Note that this means that nRESET will remain low for a minimum of 16ms. BnRES becomes active once the de-bounced nRESET goes high once more, which disables PLL1 and PLL2. The CPU may read the PMUSTAT register, which will return 0x106:

Bit	Meaning
Bit 1 set:	PLL1 has been `unlocked'
Bit 2 set:	PLL2 has been `unlocked'
Bit 8 set:	A RESET event has occurred.

Table 5-3 PMU Bit Settings for a Software Generated Warm Reset within PMUSTAT Register

5.4.3 An Externally generated Warm Reset

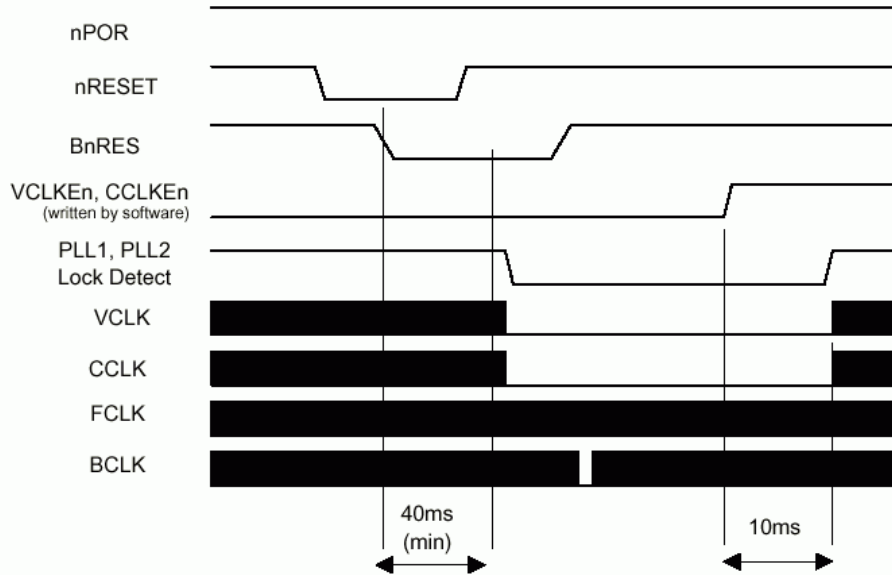

Figure 5-4 PMU An Externally Generated Warm Reset

nRESET is driven to '0' by external hardware. The nRESET input is filtered by a de-bounce circuit. Note that this means that nRESET must remain low for a minimum of 40ms. BnRES (the on-chip reset signal) becomes active as soon as nRESET is low, and high once the de-bounced nRESET goes high once more. BnRES disables PLL1 and PLL2. The CPU may read the RESET register, which will return 0x106:

Bit	Meaning
Bit 1 set:	PLL1 has been 'unlocked'
Bit 2 set:	PLL2 has been 'unlocked'
Bit 8 set:	A RESET event has occurred.

Table 5-4 PMU Bit Settings for a Warm Reset within PMUSTAT Register

Note

The internal chip reset, BnRES, remains active for 20ms after an externally generated nRESET. External devices should not assume that the HMS30C7202 is in an active state during this period.

6 SDRAM CONTROLLER

The SDRAM controller operates at the full CPU core frequency (FCLK = SCLK) and is connected to the core via the ASB bus. Internally the SDRAM controller arbitrates between access requests from the main AMBA bus, and the video bus.

It can control up to two SDRAMs of 16Mx16 density maximum. To reduce the system power consumption it can power down these individually using the Clock Enable (CKE). When the MCU is in standby mode the SDRAMs are powered down into self-refresh mode.

SDRAMs achieve the highest throughput when accessed sequentially – like video data. However accesses from the core are less regular. The SDRAM controller uses access predictability to maximize the memory interface bandwidth by having access to the LCD address buses.

Video accesses to the SDRAM occur in fixed-burst lengths of 16 words; At each Video access, SDRAM controller issues 4 consecutive "Read" commands of which burst length is 8 half-word. So, If you want to get the successive 16 words, the start address of SDRAM read must be arranged to 4-Word(8-HalfWord) boundary - The start address of SDRAM must be 0xXXXX_XXX0.

ARM and DMA controller accesses occur in a fixed-burst length of four words. If the requested accesses are shorter than four words, then the extra data is ignored. In Addition, ARM/DMA Access SDRAM Controller discards the data of which the address is not sequentially increased. For example, If ARM do the 4-Word "ldm(load Block data)" of which start address is 0x4000_0004, the Address output from SDRAM Controller to SDRAM is start from 2 (just 4bits from LBS). SDRAM do the 8-HalfWord Burst Read and it's address sequence is 2-3-4-5-6-7-0-1. In that case, SDRAM Controller discards data from address 0,1 and just get the 6-HalfWord Data(Address from 2 to 7). After that, SDRAM Controller issue the "Read" Command again of which Start address to SDRAM is 8 and gets the 2-HalfWord data(data from SDRAM address 8,9).

FEATURES

- 16 Bits wide external bus interface (two access requires for each word)
- Supports 16/64/128/256Mbit device
- Supports 2~64 Mbytes in up to two devices (the size of each memory device may be different)
- Programmable CAS latency
- Supports 2/4 banks with page lengths of 256 or 512 half words
- Programmable Auto Refresh Timer
- Support low power mode when IDLE (each device's CKE is disable individually).
- Support External Device interface with DMA channel 2.

6.1 Supported Memory Devices

2-64Mbytes of SDRAM are supported with any combination of one or two 16/64/128/256Mbit devices. Each device is mapped to a 32 Mbyte address space. The MMU (memory management unit) maps different device combinations (e.g. 16- and 64Mbit devices) into a continuous address space for the ARM core. Note that 16Mbit devices appear eight times, and 64Mbit devices appear twice in the memory map.

Total Memory	16Mbit devices	64Mbit devices	128Mbit devices	256Mbit devices
2Mbyte	1	-	-	-
4Mbyte	2	-	-	-
8Mbyte	-	1	-	-
16Mbyte	-	2	1	-
32Mbyte	-	-	2	1
64Mbyte	-	-	-	2

Note

The MMU (memory management unit) must be programmed according to the actual memory configuration (combination of 16/64/128/256 Mbit SDRAMs).

The SDRAM controller allows up to four memory banks to be open simultaneously. The open banks may exist in different physical SDRAM devices.

6.2 Registers

The SDRAM controller has four registers: the configuration, refresh timer, the Write Buffer Flush timer and wait driver. The configuration register's main function is to specify the number of SDRAMs connected, and whether they are 2- or 4-bank devices. The refresh timer gives the number of BCLK ticks that need to be counted in-between each refresh period. The Write Buffer Flush timer is used to set the number of BCLK ticks since the last write operation, before the write buffer's contents are transferred to SDRAM. The wait driver is used to set wait delay for external slow device.

Address	Name	Width	Default	Description
0x8000.0000	SDCON	32	0x00700000	Configuration register
0x8000.0004	SDREF	16	0x0080	Refresh timer
0x8000.0008	SDWBF	3	0x1	Write back buffer flush timer
0x8000.000C	SDWAIT	4	0x1	Wait driver register

Table 6-1 SDRAM Controller Register Summary

In addition to the SDRAM control registers, the ARM may access the SDRAM mode registers by writing to a 64MByte address space referenced from the SDRAM mode register base address. Writing to the SDRAM mode registers is discussed further in 6.3 Power-up Initialization of the SDRAMs.

6.2.1 SDRAM Controller Configuration Register (SDCON)

31	30	...	24	23	22	21	20	19	18	17	...	7	6	...	3	2	...	0x8000.0000
S1	S0	-	W	R	A	C1	C0	D	C	B	-	E1	B1	-	E0	B0	-	
Bits	Type	Function																
31:30	R	SDRAM controller Status 11:Reserved 10:Self refresh 01:Busy 00:Idle																
24	R/W	<i>Wait driver enable bit for test purpose</i>																
23	R/W	Normal SDRAM controller refresh enable 1 = the SDRAM controller provides refresh control 0 = the SDRAM controller does not provide refresh																
22	R/W	Auto pre-charge on ASB accesses 1 = auto pre-charge (default) 0 = no auto pre-charge If auto pre-charge is enabled, SDRAM controller issues "Read/Write with Auto Pre-charge" command instead of normal "Read/Write" command. So, SDRAM controller generates "Active" command before each Read/Write operation. If auto-pre-charge is disabled, SDRAM controller uses normal "Read/Write" command and SDRAM page that is accessed before remains active. So, SDRAM Controller automatically issues "Pre-charge" command only in the case that One SDRAM page is active and there is need to read/write the other page address in the same bank. You had better disable auto pre-charge bit, if a number of SDRAM accesses occur in the same page boundary - You can perform SDRAM "Read/Write" command fastly without "Pre-charge" & "Active" command.																
21:20	R/W	11:CAS latency3	10:CAS latency2 01:CAS latency1 00:Reserved															
19	R/W	SDRAM bus tri-state control 0 = the controller drives the last data onto the SDRAM data bus (default) 1 = the SDRAM bus is tri-stated except during writes																

		This bit should be cleared before the IC enters a low power mode. Driving the data lines avoids floating inputs that could increase device power consumption. During normal operation the D bit should be set, to avoid data bus drive conflicts with SDRAM.
18	R/W	SDRAM clock enable control 0 = the clock of IDLE devices are disabled to save power (default) 1 = all clock enables are driven HIGH continuously
17	R/W	Write buffer enable Value = 1 if the write buffer is enabled Value = 0 if the write buffer is disabled
7	R/W	1 = a device is present at address range 32-64Mbyte 0 = no device present at address range 32-64Mbyte The bit E is used to control the auto-refresh
6	R/W	Specifies the number of banks of the SDRAM at address range 32-64Mbyte 1 = the SDRAM is a four-bank device 0 = the SDRAM is a two-bank device
3	R/W	1 = a device is present at address range 0-32MByte 0 = no device present at address range 0-32Mbyte The bit E is used to control the auto-refresh
2	R/W	Specifies the number of banks of the SDRAM at address range 0-32Mbyte 1 = the SDRAM is a four-bank device 0 = the SDRAM is a two-bank device

The SDRAM controller powers-up with E[1:0]=00 and R=0. This indicates that the memory interface is IDLE. Next, the software should set at least one E bit to 1 with the R bit 0. This will cause both devices to be precharged (if present). The next operation in the initialization sequence is to auto-refresh the SDRAMs. Note that the number of refresh operations required is device-dependent. Set R=1 and E[1:0]=00 to start the auto-refresh process. Software will have to ensure that the prescribed number of refresh cycles is completed before moving on to the next step. The final step in the sequence is to set R=1 and to set the E bits corresponding to the populated slots. This will put the SDRAM controller (and the SDRAMs) in their normal operational mode. After that SDRAM mode register (in the SDRAM, not SDICON) must be initialized as to Write Burst Mode = "Programmed Burst Length", Burst Type = "Sequential", Burst Length = "8".

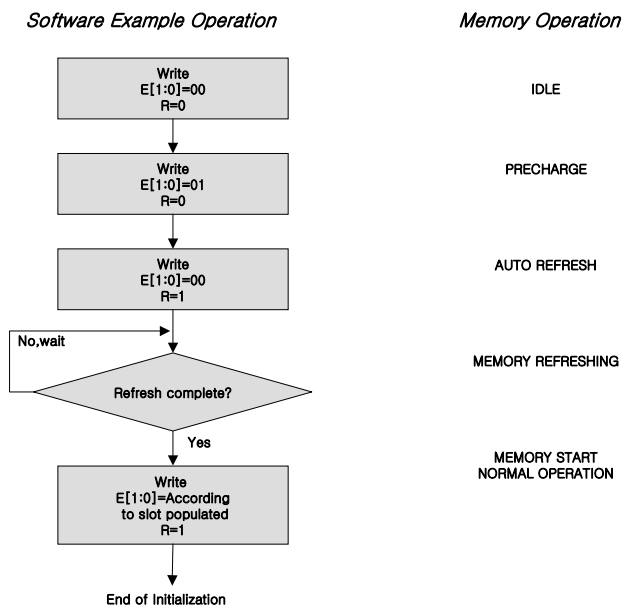

Figure 6-1 SDRAM Controller Software Example and Memory Operation Diagram

6.2.2 SDRAM Controller Refresh Timer Register (SDREF)

	0x8000.0004
-	15 - 0
Reserved	SDREF

Bits	Type	Function
15:0	R/W	<p>A 16-bit read/write register that is programmed with the number of BCLK ticks that should be counted between SDRAM refresh cycles. For example, for the common refresh period of 16μs, and a BCLK frequency of 50MHz, the following value should be programmed into it:</p> $16 \times 10^{-6} * 50 \times 10^6 = 800$ <p>The refresh timer defaults to a value of 128, which for a 16μs refresh period assumes a worst case (i.e. slowest) clock rate of:</p> $128 / (16 \times 10^{-6}) = 8 \text{ MHz}$ <p>The refresh register should be programmed as early as possible in the system start-up procedure, and in the first few cycles if the system clock is less than 8MHz.</p>

6.2.3 SDRAM Controller Write buffer flush timer Register (SDWBF)

	0x8000.0008
-	2 - 0
Reserved	SDWBF

Bits	Type	Function																		
2:0	R/W	<p>A 3-bit read/write register that sets the time-out value for flushing the quad word merging write buffer. The times are given in the following table.</p> <table style="margin-left: 20px; border-collapse: collapse;"> <thead> <tr> <th style="text-align: left;">Timer value</th> <th style="text-align: left;">BCLK ticks between time-outs</th> </tr> </thead> <tbody> <tr><td>111</td><td>128</td></tr> <tr><td>110</td><td>64</td></tr> <tr><td>101</td><td>32</td></tr> <tr><td>100</td><td>16</td></tr> <tr><td>011</td><td>8</td></tr> <tr><td>010</td><td>4</td></tr> <tr><td>001</td><td>2</td></tr> <tr><td>000</td><td>Time-out disabled</td></tr> </tbody> </table>	Timer value	BCLK ticks between time-outs	111	128	110	64	101	32	100	16	011	8	010	4	001	2	000	Time-out disabled
Timer value	BCLK ticks between time-outs																			
111	128																			
110	64																			
101	32																			
100	16																			
011	8																			
010	4																			
001	2																			
000	Time-out disabled																			

6.2.4 SDRAM Controller Wait Driver Register (SDWAIT)

	0x8000.000C
-	3 - 0
Reserved	SDWAIT

Bits	Type	Function
3:0	R/W	<p>This value specifies the waited delay time (BCLK cycles) of the BWAIT signal of the system bus (AMBA ASB); default value is 1. This register affects only the external device with DMA channel-2 operation and does not affect channel-0 and channel-1. During access to the external device with DMA channel-2, Write-Back buffer is always enable even if SDCON (SDRAM Controller Configuration Register)'s W bit (Write-Back buffer enable) is reset (disabling the operation of Write-Back Buffer).</p>

6.3 Power-up Initialization of the SDRAMs

The SDRAMs are initialized by applying power, waiting a prescribed amount of settling time (typically 100 μ s), performing at least 2 auto-refresh cycles and then writing to the SDRAM mode register. The exact sequence is

SDRAM device-dependent.

The settling time is referenced from when the SDRAM CLK starts. The processor should wait for the settling time before enabling the SDRAM controller refreshes, by setting the R bit in the SDRAM control register. The SDRAM controller automatically provides an auto refresh cycle for every refresh period programmed into the Refresh Timer when the R bit is set. The processor must wait for sufficient time to allow the manufacturer's specified number of auto-refresh cycles before writing to the SDRAM's mode register.

The SDRAM's mode register is written to via its address pins (A[14:0]). Hence, when the processor wishes to write to the mode register, it should read from the binary address (AMBA address bits [24:9]), which gives the binary pattern on A[14:0] which is to be written. The mode register of each of the SDRAMs may be written to by reading from a 64Mbyte address space from the SDRAM mode register base address. The correspondence between the AMBA address bits and the SDRAM address lines (A[14:0]) is given in the Row address mapping of Table 6-2 SDRAM Row/Column Address Map. Bits [25] of the AMBA address bus select the device to be initialized.

The SDRAM must be initialized to have the same CAS latency as is programmed into C[1:0] bits of the SDRAM control register, and always to have a burst length of 8.

6.4 SDRAM Memory Map

The SDRAM controller can interface with up to two SDRAMs of 1Mx16, 4Mx16, 8Mx16 or 16Mx16 density. The SDRAMs may be organized in either two or four banks. The controller can address 64Mbyte, subdivided into two 32Mbyte blocks, one for each SDRAMs.

The mapping of the AMBA address bus to the SDRAM row and column addresses is given in Table 6-2. The first row of the diagram indicates the SDRAM Controller Address output (SA[14:0]) and the SDRAM address bit (BS1, BS0, A12~A0); If you use 64Mbit SDRAM, you should connect A11~A0 to SA[11:0] and BS0~1 to SA[13:12].

The remaining numbers indicate the AMBA address bits MBA[24:1].

SDRAM ADDR	SA[14] A12	SA[13] BS0	SA[12] BS1	SA[11] A11	SA[10] A10	SA[9] A9	SA[8] A8	SA[7] A7	SA[6] A6	SA[5] A5	SA[4] A4	SA[3] A3	SA[2] A2	SA[1] A1	SA[0] A0
Row 16Mbit	24	10*	9*	22	20*	Note 1	19*	18*	17*	16*	15*	14*	13*	12*	11*
Col 16Mbit	24	10*	9*	Note1	20	Note 1	23	8*	7*	6*	5*	4*	3*	2*	Note2
Row 64Mbit	24	10*	9*	22*	20*	21*	19*	18*	17*	16*	15*	14*	13*	12*	11*
Col 64Mbit	24	10*	9*	22	20	21	23	8*	7*	6*	5*	4*	3*	2*	Note2
Row 128Mbit	24	10*	9*	22*	20*	21*	19*	18*	18*	16*	15*	14*	13*	12*	11*
Col 128Mbit	24	10*	9*	22	20	21	23*	8*	7*	6*	5*	4*	3*	2*	Note2
Row 256Mbit	24*	10*	9*	22*	20*	21*	19*	18*	18*	16*	15*	14*	13*	12*	11*
Col 256Mbit	24	10*	9*	22	20	21	23*	8*	7*	6*	5*	4*	3*	2*	Note2
Mode Write	24*	10*	9*	22*	20*	21*	19*	18*	17*	16*	15*	14*	13*	12*	11*
Summary	24	10	9	22	20	21	19/23	18/8	17/7	16/6	15/5	14/4	13/3	12/2	11*

Table 6-2 SDRAM Row/Column Address Map

Notes

(1) For the 16Mbit device, SDRAM address line A11 should be connected to the HMS30C7202 pin SA[13](BS0), and the SDRAM address line A9 should be connected to the HMS30C7202 pin SA[12](BS1). The HMS30C7202 address lines SA[11] and SA[9] should not be connected.

(2) Since all burst accesses commence on a word boundary, and SDRAM addresses are non-incrementing (the address incremented is internal to the device), column address zero will always be driven to logic '0'.

* An asterisk denotes the address lines that are used by the SDRAM.

The start address of each SDRAM is fixed to a 32Mbyte boundary. The memory management unit will be used to map the actual banks that exist into contiguous memory as seen by the ARM. Bits [25] of the AMBA address

bus select the device to be initialized, as described in Table 6-3.

A25	Device selected
0	Device 0
1	Device 1

Table 6-3 SDRAM Device Selection

6.5 AMBA Accesses and Arbitration

The SDRAM controller bridges both the AMBA Main and Video buses. On the Main bus, the SDRAM appears as a normal slave device. On the Video DMA bus, the SDRAM controller integrates the functions of the bus arbiter and address decoder. Writes from the main bus may be merged in the quad word merging write buffer. A Main/Video arbiter according to the following sequence arbitrates access requests from either the Main or Video buses:

- Highest Priority: LCD Refresh request
- Lowest Priority: Main bus peripheral (PMU, ARM, DMA)--order determined by Main bus arbiter.

Video SDRAM accesses always occur in bursts of 16 words. Once a burst has started, the SDRAM controller provides data without wait states. Video data is only read from SDRAM, no write path is supported.

If a refresh cycle is requested, then it will have lower priority than the Video bus, but will be higher than any other accesses from the Main bus. Assuming a worst-case BCLK frequency of 8MHz, the maximum, worst-case latency that the arbitration scheme enforces is 11.5us before a refresh cycle can take place. This is comfortably within the 16us limit. Note that the 2 external SDRAM devices are refreshed on 2 consecutive clock cycles to reduce the peak current demand on the power source.

The arbitration of the Main bus is left to the Main bus arbiter. Data transfers requested from the Main bus always occur as a burst of eight half-word accesses to SDRAM. The Main bus arbiter cannot break into access requests from the Main bus. In the case where fewer than four words are actually requested by the Main bus peripheral, the excess data from the SDRAM is ignored by the SDRAM controller in the case of read operations, or masked in the case of writes. In the case where more than four words are actually requested by the Main bus peripheral, the SDRAM controller asserts BLAST to force the ASB decoder to break the burst.

In the case of word/half-word/byte misalignment to a quad word boundary (when any of address bits [3:0] are non-zero at the start of the transfer), BLAST is asserted at the next quad word boundary (bits 3, 2, 1 and 0 properly set 1 for each type) to force the ASB decoder to break the burst.

Sequential half word (or byte) reads are supported and the controller asserting BLAST at quad word boundary.

In the case of byte or half word reads, data is replicated across the whole of the ASB data bus.

Data bus for word access:

31 23 15 7 0
d31 d30 d29 d28 d27 d26 d25 d24 d23 d22 d21 d20 d19 d18 d17 d16 d15 d14 d13 d12 d11 d10 d9 d8 d7 d6 d5 d4 d3 d2 d1 d0

Data bus for half word access:

31 23 15 7 0
d15 d14 d13 d12 d11 d10 d9 d8 d7 d6 d5 d4 d3 d2 d1 d0 d15 d14 d13 d12 d11 d10 d9 d8 d7 d6 d5 d4 d3 d2 d1 d0

Data bus for byte access:

31 23 15 7 0
d7 d6 d5 d4 d3 d2 d1 d0 d7 d6 d5 d4 d3 d2 d1 d0 d7 d6 d5 d4 d3 d2 d1 d0 d7 d6 d5 d4 d3 d2 d1 d0

6.6 Merging Write Buffer

An eight word merging Write-Buffer is implemented in the SDRAM controller to improve write performance. The write buffer can be disabled, but its operation is completely transparent to the programmer. The eight words of the buffer are split into two quad words, the same size as all data transactions to the SDRAMs. The split into two quad words allows one quad word to be written to at the same time as the contents of the other

are being transferred to SDRAM. The quad word buffer currently being written to may be accessed with non-contiguous word, half word or byte writes, which will be merged into a single quad word. The buffered quad word will be transferred to the SDRAM when:

- There is a write to an SDRAM address outside the current quad word being merged into
- There is a read to the address of the quad word being merged into
- There is a time-out on the write back timer

The two quad-words that make up the write buffer operate in "ping-pong" fashion, whereby one is initially designated the buffer for writes to go into, and the other is the buffer for write backs. When one of the three events that can cause a write-back occurs, the functions of the two buffers are swapped. Thus the buffer containing data to be written back becomes the buffer that is currently writing back, and the buffer that was the write-back buffer becomes the buffer being written to.

In the case of a write-back initiated by a read from the same address as the data in the merge buffer, the quad word in the buffer is written to SDRAM, and then the read occurs from SDRAM. The write before read is essential, because not all of the quad word in the buffer may have been updated, so its contents need to be merged with the SDRAM contents to fill any gaps where the buffer was not updated. The write buffer flush timer forces a write back to occur after a programmable amount of time. Every time a write into the buffer occurs, the counter is re-loaded with the programmed time-out value, and starts to counts down. If a time-out occurs, then data in the write buffer is written to SDRAM.

7 STATIC MEMORY INTERFACE

The Static Memory Controller (SMI) interfaces the AMBA Advanced System Bus (ASB) to the External Bus Interface (EBI). It controls four separate memory or expansion banks. Each bank is 32MB in size and can be programmed individually to support:

- 8-, 16- or 32-bit wide, little-endian memory
- Variable wait states (up to 16)
- Burst mode read access

Burst mode access allows fast sequential access within quad word boundaries. This can significantly improve bus bandwidth in reading from memory (that must support at least four word burst reads). In addition, bus transfers can be extended using the EXPRDY input signal.

7.1 External Signals

Pin Name	Type	Description
EXPRDY	I	Expansion channel ready. When LOW, during phase one this signal will force the current memory transfer to be extended.
nRWE [3:0]	O	These signals are active LOW write enables for each of the memory byte lanes on the external bus.
nROE	O	This is the active LOW output enable for devices on the external bus.
nRCS [3:0]	O	Active LOW chip selects.
RA [24:0]	O	ROM Address Bus
RD [31:0]	I/O	ROM Data Bus
BOOTSBIT [1:0]	I	Configuration input. 00 - Select bank 0 as 32-bit memory 01 - Select bank 0 as 16-bit memory 10 - Select bank 0 as 8-bit memory 11 - Reserved

7.2 Functional Description

The main functions of the Static Memory Controller (SMI) are :

- Memory bank select
- Access sequencing
- Wait states generation
- Burst read control
- Byte lane write control

These are described below

7.2.1 Memory bank select

Start Address	Address (Hex)	Size	Description
0 Mbytes	0x0000.0000	32Mbytes	ROM chip select 0
64 Mbytes	0x0400.0000	32Mbytes	ROM chip select 1
128 Mbytes	0x0800.0000	32Mbytes	ROM chip select 2
192 Mbytes	0x0C00.0000	32Mbytes	ROM chip select 3

7.2.2 Access sequencing

The bank configuration also determines the width of the external memory devices. When the external memory bus is narrower than the transfer initiated from the current master, the internal transfer will take several external bus transfers to complete. For example, in case that memory Bank0 is configured as 8-bit wide memory and a 32-bit read is initiated the AMBA bus stalls while the SMI read four consecutive bytes from the

memory. During these accesses the data path is controlled (in the EBI) to demultiplex the four bytes into one 32-bit word on the AMBA ASB bus.

7.2.3 Wait states generation

The Static Memory Controller supports wait states for read and write accesses. This is configurable between one and 16 wait states for standard memory access, and zero and 15 wait states for burst mode. The Static Memory Controller also allows transfers to be extended indefinitely, using the EXPRDY signal. To hold the current transfer, EXPRDY must be LOW on the falling edge of BCLK before the last cycle of the accesses. The transfer cannot complete until EXPRDY is HIGH for at least one cycle.

7.2.4 Burst read control

Up to four consecutive locations in 8-, 16- or 32-bit memories can be read in one burst. If the bus width of external memory is less than that of internal bus, you have to set the value of **BURST READ WAIT STATE** in 7.3.1 *MEM Configuration Register* more than 1 cycle for stable data transfers between them.

7.2.5 Byte lane write control

This controls nRWE [3:0] according to transfer width, BA [1:0] and the access sequencing. The table below shows nRWE coding case by little endian accessing to 32,16,8-bit external memory bus.

CASE1. ACCESS: Write, 32-Bit external bus

BSIZE [1:0]	BA [1:0]	nRWE [3:0]
10(WORD)	XX	0000
01(HALF)	1X	0011
	0X	1100
00(BYTE)	11	0111
	10	1011
	01	1101
	00	1110

CASE2. ACCESS: Write, 16-Bit external bus

BSIZE [1:0]	BA [1:0]	IA [1:0]^{†1}	nRWE [3:0]
10(WORD)	XX	1X	1100
	XX	0X	1100
01(HALF)	1X	1X	1100
	0X	0X	1100
00(BYTE)	11	1X	1101
	10	1X	1110
	01	0X	1101
	00	0X	1110

CASE3. ACCESS: Write, 8-Bit external bus

BSIZE [1:0]	BA [1:0]	IA [1:0]^{†1}	nRWE [3:0]
10(WORD)	XX	11	1110
	XX	10	1110
	XX	01	1110
	XX	00	1110
01(HALF)	1X	11	1110
	1X	10	1110
	0X	01	1110

	0X	00	1110
00(BYTE)	11	11	1110
	10	10	1110
	01	01	1110
	00	00	1110

Note *1 IA [1:0] : internal SMI address

7.3 Registers

Address	Name	Width	Default	Description
0x8000.3000	MEMCFG0		0x0	Memory Configuration Register 0
0x8000.3004	MEMCFG1		0x0	Memory Configuration Register 1
0x8000.3008	MEMCFG2		0x0	Memory Configuration Register 2
0x8000.300C	MEMCFG3		0x0	Memory Configuration Register 3

Table 7-1 Static Memory Controller Register Summary

7.3.1 MEM Configuration Register

				11	10	9	8	7	6	5	4	3	2	1	0
				BUR EN	BURST READ WAIT STATE				NORMAL ACCESS WAIT STATE					MEM WIDTH	
Bits	Type	Function													
31:12	-	Reserved													
11	R/W	Burst Enable. Setting this bit enables burst reads to take advantage of faster access times from memory devices that support burst mode.													
10:7	R/W	Value	Number of Burst Read Wait State												
		1111	0												
		1110	1												
													
		0001	14												
		0000	15 (default)												
6:3	R/W	Value	Number of Normal Access Wait State												
		1111	1												
		1110	2												
													
		0001	15												
		0000	16 (default)												
2	-	Reserved													
1:0	R/W	Value	Memory Width												
		11	Reserved												
		10	8 bit memory access												
		01	16 bit memory access												
		00	32 bit memory access												

7.4 Examples of the SMI Read, Write wait timing diagram

The following timing diagrams show sequential and non-sequential read and write accesses. For information on the AMBA bus internal signals refer to the AMBA specification (ARM IHI 0011A)

7.4.1 Read normal wait (Non-Sequential mode)

This timing diagram shows a non-sequential read accesses with 5 wait cycles (MEM config register = 0x058).

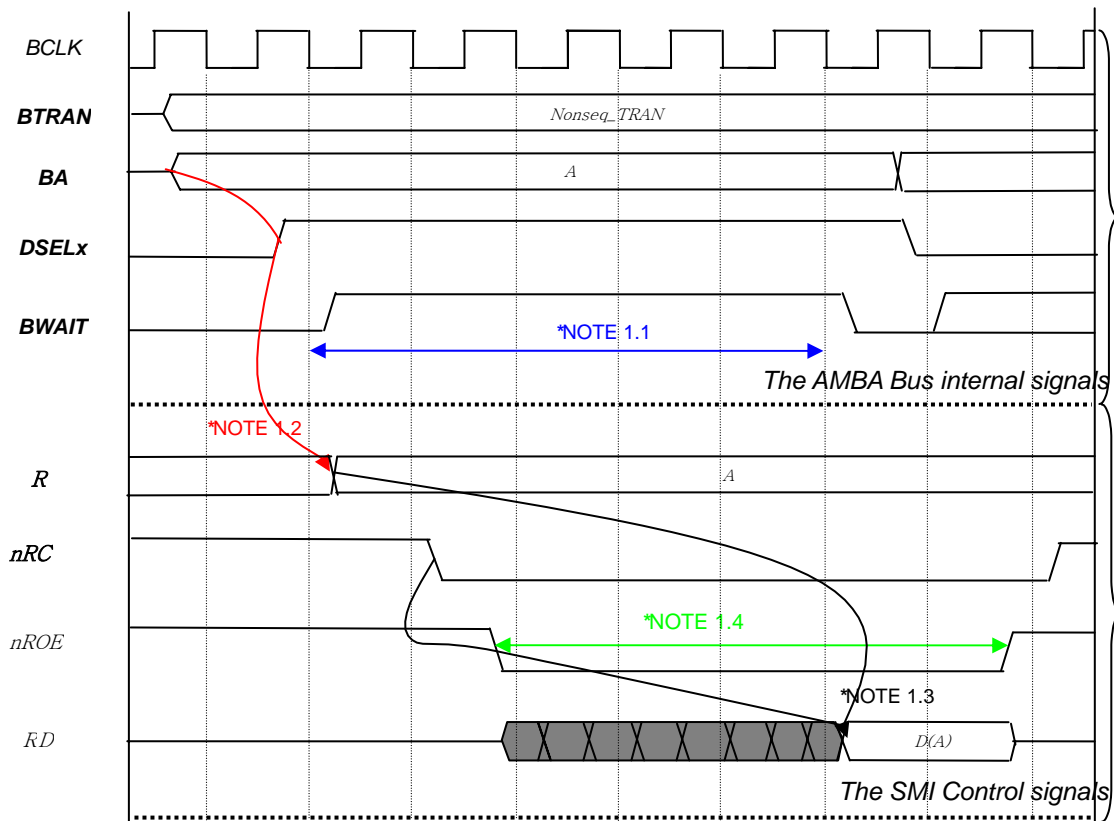

*NOTE 1.1: BWAIT time = BCLK x 5 wait cycle

*NOTE 1.2: Valid the SMI address latch on the ASB Bus address when BA and DSEL are valid condition.

*NOTE 1.3: After generated SMI control signals and the end of 5wait cycles, external device read data is valid with SMI address (RA), nRCS, and nROE.

*NOTE 1.4: External Memory access time. It is the same as Wait time (i.e. BWAIT cycle time = 5 wait cycle)

7.4.2 Read normal wait (Sequential mode)

This timing diagram shows a sequential read accesses with 3 wait cycles (MEM config register = 0x068)

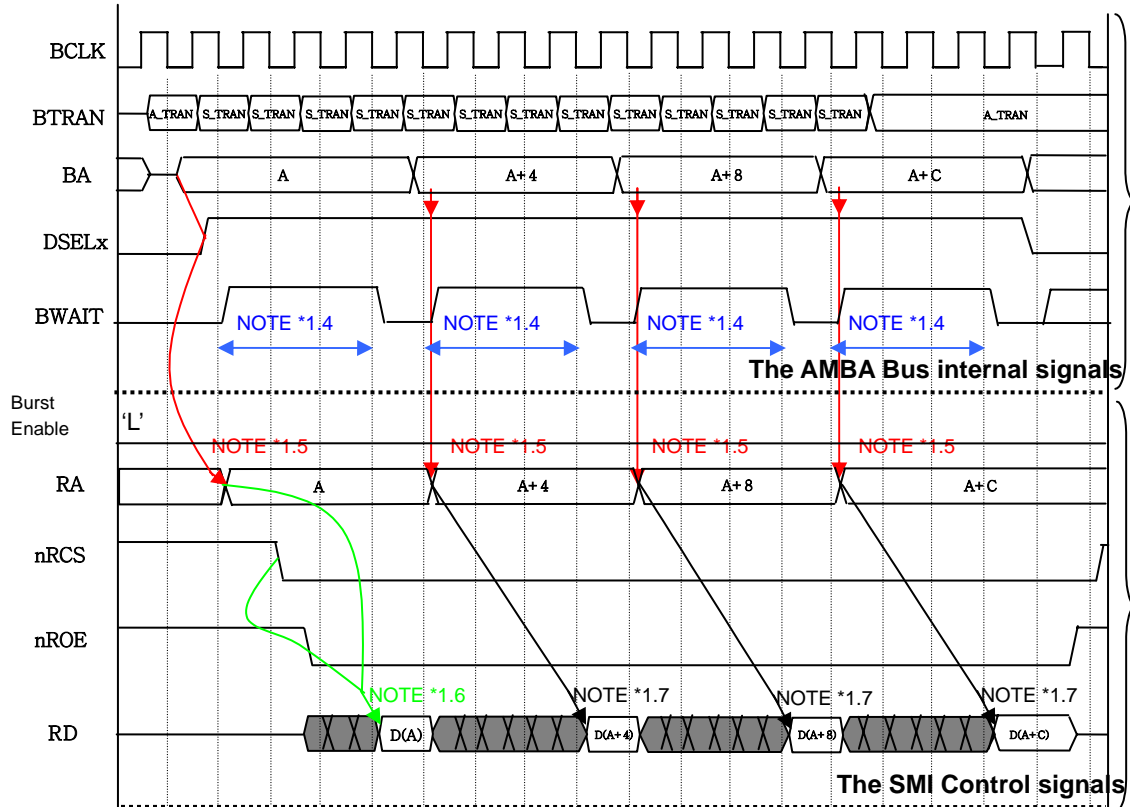

*NOTE 1.4: BWAIT time = BCLK x 3 wait cycle (If MCR is set)

*NOTE 1.5: Valid the SMI address latch on the ASB Bus address when BA and DSEL are valid condition.

*NOTE 1.6: After generated SMI control signals, external device read data is valid with SMI address(RA), nRCS, and nROE.

*NOTE 1.7: The BTRAN is sequential transfer so the SMI control signal (nRCS, nROE) are not asserted any more, and then external device read data is valid with SMI address (RA).

7.4.3 Read burst wait (Sequential mode)

This timing diagram shows a sequential burst read accesses with 3 wait cycles (MEM config register = 0xE60)

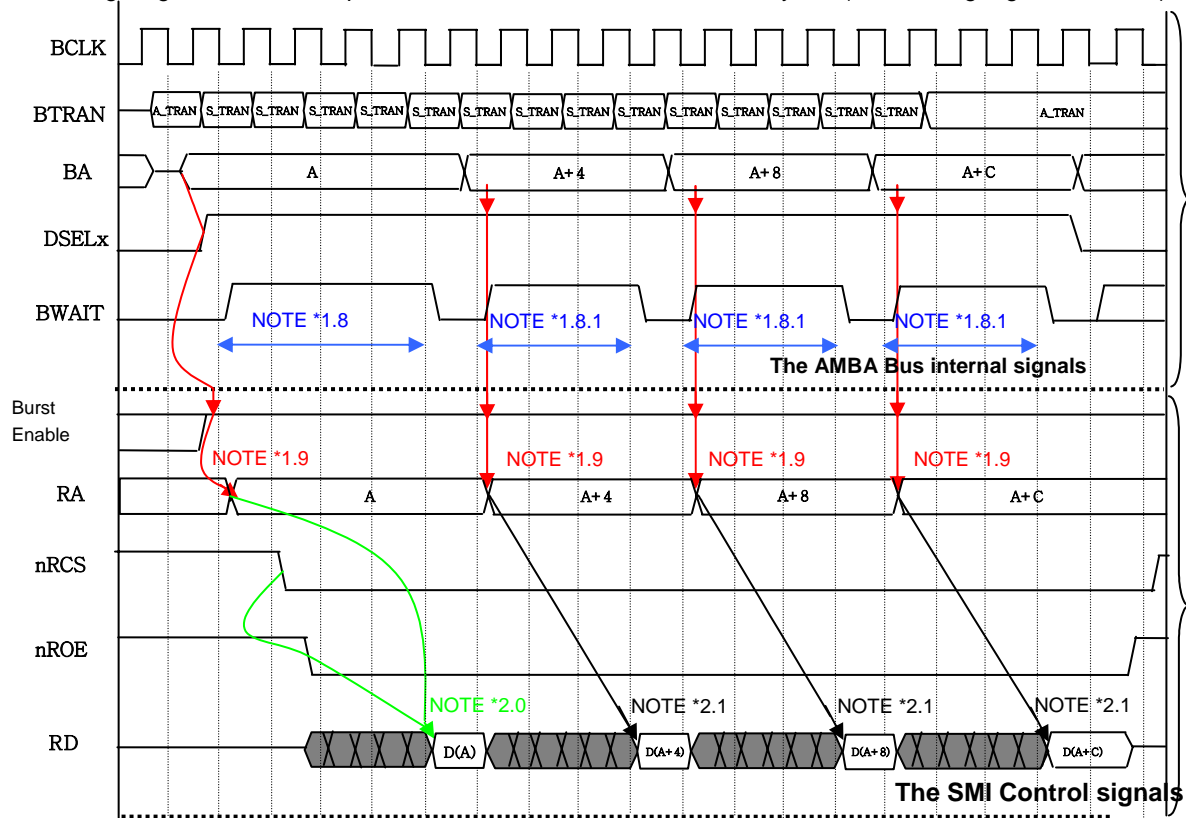

- *NOTE 1.8 : For the 1st read of a Burst read transfer the wait time is Normal Wait time (in this example 4 cycles).
- *NOTE 1.8.1: BWAIT time = BCLK x 3 wait cycle (If MCR is set)
- *NOTE 1.9: Valid the SMI address latch on the ASB Bus address when BA, DSEL, and BurstEnable are valid condition.
- *NOTE 2.0: After generated SMI control signals, external device read data is valid with SMI address (RA), nRCS, and nROE.
- *NOTE 2.1: The BTRAN is sequential transfer so the SMI control signal (nRCS, nROE) are not asserted any more, and then external device read data is valid with SMI address (RA).

Above the figure of burst wait signals; make sure that BurstEnable signal will be change (High to Low) at the BA is become to different value.

7.4.4 Write normal wait (Sequential mode)

This timing diagram shows a sequential write accesses with 3 wait cycles (MEM config register = 0x068).

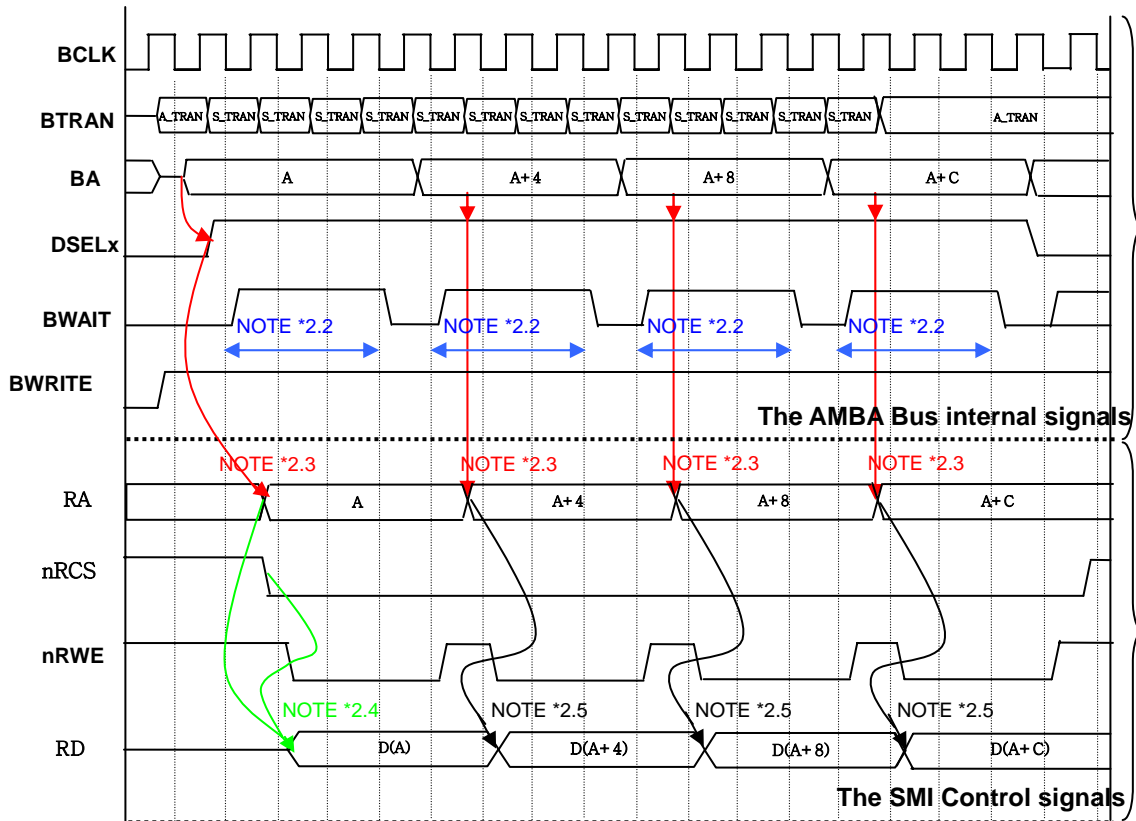

*NOTE 2.2: BWAIT time = BCLK x 3 wait cycle (If MCR is set)

*NOTE 2.3: Valid the SMI address latch on the ASB Bus address when BA and DSEL are valid condition.

*NOTE 2.4: After generated SMI control signals, external device write data is valid with SMI address (RA), nRCS, and nRWE.

*NOTE 2.5: The BTRAN is Sequential transfer so nRCS external chip enable signal is not asserted, but nRWE external write enable signal asserted on the falling edge of BCLK.

7.5 Internal SRAM

7.5.1 Remapping Enable Register

HMS30C7202 allows the remapping of the internal SRAM block (Base address : 0x7F00.0000 - 2KB size) to enhance the performance.

								0x8000.1040
31	30	29	28	27	26	25	24	
Reserved								
23	22	21	20	19	18	17	16	
Reserved								
15	14	13	12	11	10	9	8	
Reserved				Remap Size				
7	6	5	4	3	2	1	0	
Remap Size					Reserved		RemapEn	

Bits	Type	Function
31:13	-	Reserved
12:3	R/W	Remap Size (word Boundary) Caution : Max size of remapping is 0x7FF(2KB area). If remap size setting exceeds this value, the correct operation can not be guaranteed
2:1		Reserved
0	R/W	1 : Enable Remap 0 : Disable Remap

7.5.2 Remap Source Address Register

								0x8000.1048
31	30	29	28	27	26	25	24	
Reserved								
23	22	21	20	19	18	17	16	
Remap Source Address								
15	14	13	12	11	10	9	8	
Remap Source Address								
7	6	5	4	3	2	1	0	
Remap Source Address						Reserved		

Bits	Type	Function
31:25	-	Reserved
24:2	R/W	Remap Source Address Start address of Remapping(Word Boundary)
0:1		Reserved

8 LCD CONTROLLER

FEATURES

- Single panel color and monochrome STN displays
- TFT color displays
- Resolution programmable up to 640x480
- Single panel mono STN displays with either 4- or 8-bit interfaces
- 15 gray-level mono support, 3375 color STN support
- 4bpp mono, 4 or 8bpp palletized color displays
- 16bpp color 'true-color' color displays(TFT)
- Programmable timing for different display panels
- 3 x 256 entry, 5-bit Red, Blue and 6-bit Green palette RAM in TFT mode
- 3 x 256 entry, 4-bit palette RAM in STN mode
- Patented grayscale algorithm
- Little-endian operation

Note

The controller does not support dual panel STN displays.
There is no hardware cursor support, since WinCE does not use a cursor.

8.1 Video operation

A block diagram of the video system is shown in Figure 8-1: Video System Block Diagram. The video system has a data path for STN LCD and for TFT LCDs.

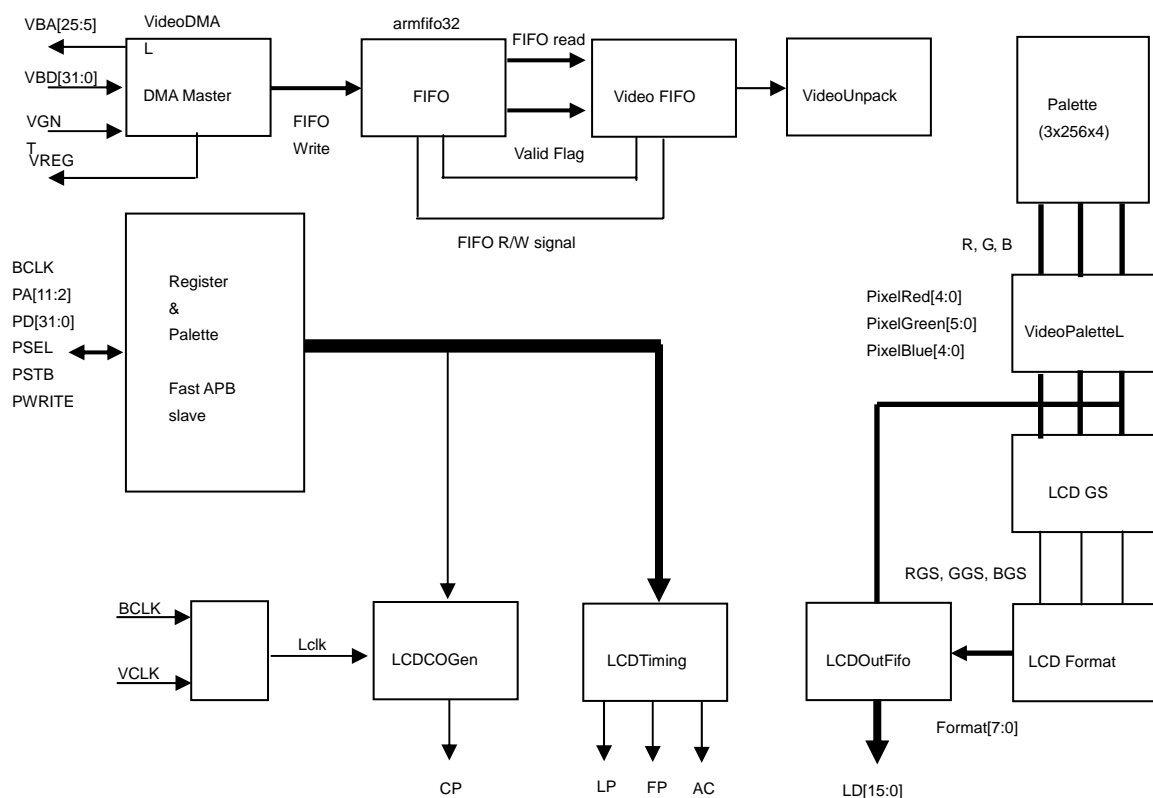

Figure 8-1 Video System Block Diagram

8.1.1 LCD datapath

In TFT mode the digital RGB data is directly available at output pins. However, in STN mode, the data must be gray scaled, and then formatted for the LCD panel. The grayscale block converts the 4 bit per color gun data into a single bit per gun, using a patented time/space dither algorithm. In mono mode, only the B gun data is used. The output of the grayscale is fed to the formatter, which formats the pixels in the correct order for the LCD panel type in use. (4 or 8 mono pixels per clock for mono panels, or 2 2/3pixels per clock for color data.) The output of the formatter in color mode is bursty, due to the 2 2/3pixels per clock that are output, so the formatter output goes to a small FIFO, which smoothes out this burstiness, before data is output to the LCD panel at a constant rate.

8.1.1.1 Palette RAM & 16bpp mode

Logical pixels are either 8 or 16 bits. In 8-bit mode, the logical pixel value is used to index into the three palette arrays to select the three color components of the physical pixel value. In 16-bit pseudo true-color mode, a patented technique is used to allow 2^{16} colors to be selected from 2^{24} possible colors. Separate color gun values are independently used to index into the three palette arrays, to select an 8-bit value for each of the color guns. By splitting the palette RAM into three separate RAM arrays, it allows 16-bit mode to generate 8-bit color gun data. The method used is an ARM patented technique, where 16bpp data is split into three overlapping 8-bit fields that are used to index into the three RAM arrays. The red gun is indexed by bits 15:8 of the 16-bit pixel value, the blue gun is indexed by bits 7:0 of the pixel value, and the green gun is indexed by bits 11:4 of the pixel value. By programming the palette with the correct values, 5:5:5, 5:6:5, 4:8:4, and many other combinations of 16-bit data may be used. Thus:

8 bpp : 256 palette entries are used for each palette array. All three palette RAMs are indexed by pixel[7:0]

16 bpp : 256 palette entries are used for each palette array. Red array is indexed by pixel[15:8], green array is indexed by pixel[11:4], and blue array is indexed by pixel[7:0]

Figure 8-2 shows 5:6:5 combination. Least significant 3bits are don't cares for red index, most significant 3bits are don't cares for blue index. Bit0 and bit7 are don't cares for green index.

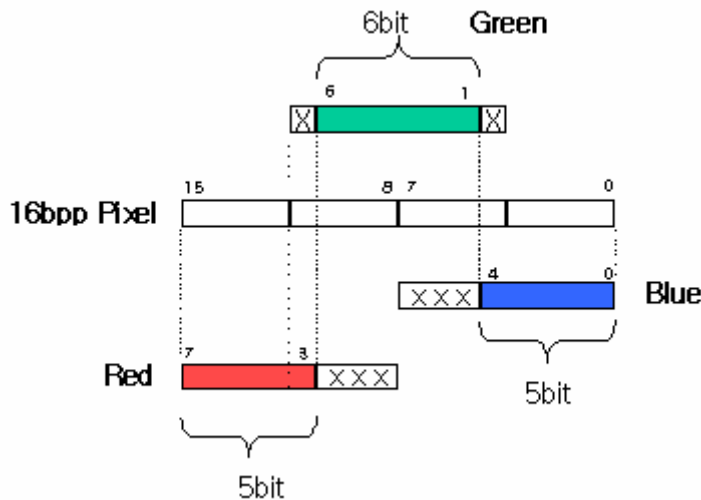

Figure 8-2 5:6:5 Combination of 16bpp Data

The effective 5, 6, and 5 bits are indexes to HMS30C7202 palette RAM for TFT mode. Figure 8-3 shows HMS30C7202 palette register mapping for 16bpp(5:6:5) representation.

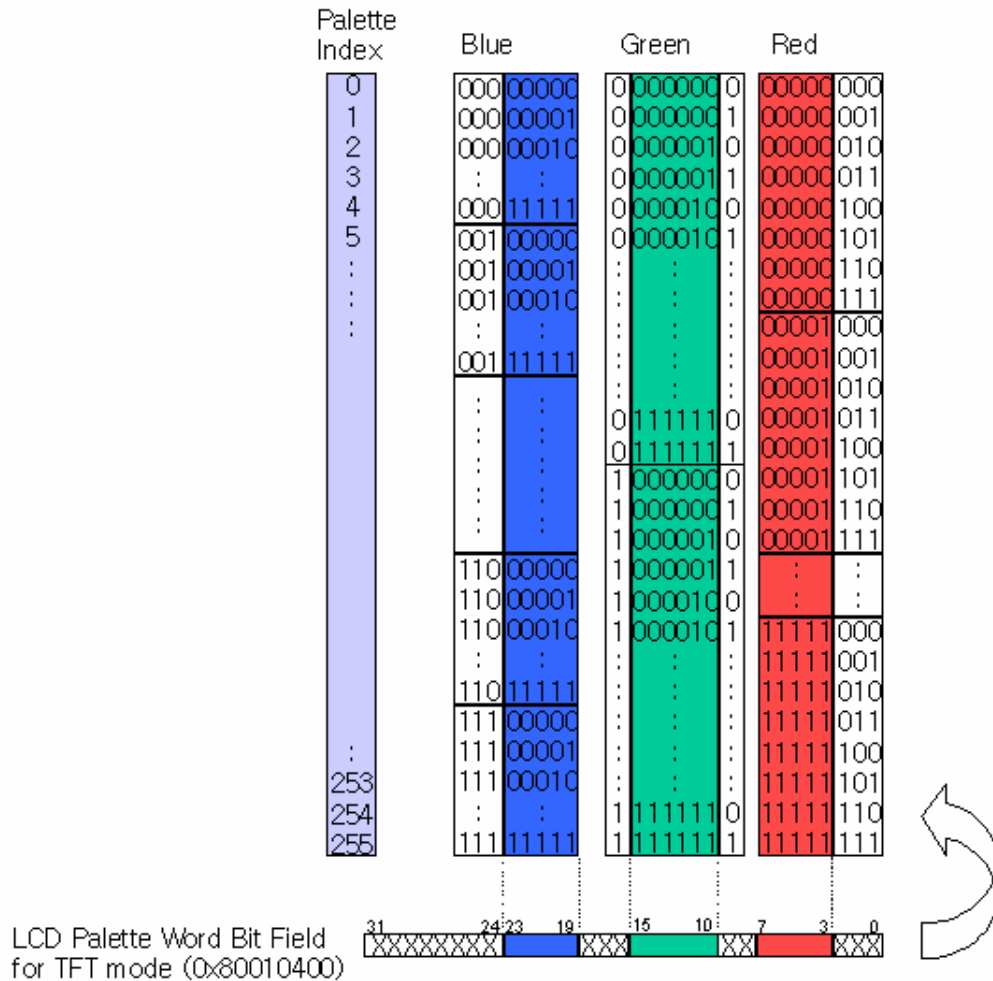

Figure 8-3 Palette RAM Entries for 5:6:5 Combination

To program palette RAM as in Figure 8-3, refer to the code in Figure 8-4.

```

unsigned long palette[256];

main ( )
{
    int i;

    for (i=0; i<256; i++)
    {
        // store 5 bits red, 6 bits green, and 5 bits blue
        palette[i] = ((i&0x1f) << 19) | ((i&0x7e) << 9) | ((i&0xf8));

        printf("%d, %02X, %02X, %02X\r\n", i, (i&0x1f) << 3, (i&0x7e) << 1, (i&0xf8) << 0);
    }
}
    
```

Figure 8-4 Sample Code for 5:6:5 Palette Generation

8.1.2 Color/Grayscale Dithering

Entries selected from the look-up palette are sent to the color/grayscale space/time base dither generator. Each 4-bit value is used to select one of 15 intensity levels.

Note that two of the 16 dither values are identical. The table below assumes that a pixel data input to the LCD panel is active HIGH. That is, a `1' in the pixel data stream will turn the pixel on, and a `0' will turn it off. If this is not the case, the intensity order will be reversed, with "0000" being the most intense color. This polarity is LCD panel dependent.

The gray/color intensity is controlled by turning individual pixels on and off at varying periodic rates. More intense grays/colors are produced by making the average time that the pixel is off longer than the average time that it is on. The proprietary dither algorithm is optimized to provide a range of intensity values that match the eye's visual perception of color/gray gradations, with smaller changes in intensity nearer to the mid-gray level, and greater nearer the black and the white levels. In color mode, red, green and blue components are gray-scaled simultaneously as if they were mono pixels. The duty cycle and resultant intensity level for all 15 color/grayscale levels is summarized in Table 8-1: Color/grayscale intensities and modulation rates.

Dither Value (4 bit value from palette)	Intensity (0% is white)	Modulation Rate (ration of ON to ON+OFF pixels)
1111	100.0	1
1110	100.0	1
1101	88.9	8/9
1100	80.0	4/5
1011	73.3	11/15
1010	66.6	6/9
1001	60.0	3/5
1000	55.6	5/9
0111	50.0	1/2
0110	44.4	4/9
0101	40.0	2/5
0100	33.3	3/9
0011	26.7	4/15
0010	20.0	1/5
0001	11.1	1/9
0000	0.0	0

Table 8-1 LCD Colorgrayscale intensities and modulation rates

8.1.3 How to order the bit on LD[7:0] output

In STN mode, the low order LD signals are the first pixels on the line, and the high order LD signals are later pixels on the line.

In color mode things are different once again. LD[7] is the red component of the first pixel on the line, and LD[6] is the green component of the pixel, and LD[5] the blue, with LD[4] being the red component of the next pixel. This pattern continues, with LD[0] being the green component of the third pixel, and LD[7] of the next clock being the blue component of the same pixel.

LCD Pin	Time Sequence						
	→						
LD[7]	R0	B2	G5	R8	...	R0	B2
LD[6]	G0	R3	B5	G8	...	G0	R3
LD[5]	B0	G3	R6	B8	...	B0	G3
LD[4]	R1	B3	G6	R9	...	R1	B3
LD[3]	G1	R4	B6	G9	...	G1	R4
LD[2]	B1	G4	R7	B9	...	B1	G4
LD[1]	R2	B4	G7	R10	...	R2	B4
LD[0]	G2	R5	B7	G10	...	G2	R5

Table 8-2 How to order the bit on LD[7:0] in 8-bit color STN mode

8.1.4 TFT mode

When TFT display mode is enabled, the timing of the pixel, line and frame clocks as well as the AC-bias pin change. The pixel clock transitions continuously in this mode as long as the LCD is enabled. The AC-bias pin functions as an output enable. When it is HIGH, the display latches data from the LCD's pins using the pixel clock. The line clock pin is used as the horizontal synchronization signal (HSYNC), and the frame clock is used as the vertical synchronization signal (VSync). Pixel data is output one pixel per clock, rather than 4, 8 or 22/3pixels per clock, as it is in the passive LCD modes.

8.2 Registers

Address	Name	Width	Default	Description
0x8001.0000	LcdControl			LCD Control Register
0x8001.0004	LcdStatus			LCD Status Register
0x8001.0008	LcdStatusM			LCD Status Mask Register
0x8001.000C	LcdInterrupt			LCD Interrupt Register
0x8001.0010	LcdDBAR			LCD DMA Channel Base Address Register
0x8001.0014	LcdDCAR			LCD DMA Channel Current Address Register
0x8001.0020	LcdTiming0			LCD Timing 0 Register
0x8001.0024	LcdTiming1			LCD Timing 1 Register
0x8001.0028	LcdTiming2			LCD Timing 2 Register
0x8001.0040	LcdTest			LCD Test register
0x8001.0044	GsfState			Grayscale production test register
0x8001.0048	GsrState			Grayscale production test register
0x8001.004C	GscState			Grayscale production test register
0x8001.0400~ 0x8001.07FC	LCDPalette			LCD Palette programming registers

Table 8-3 LCD Controller Register Summary

8.2.1 LCD Power Control

LCD displays require that the LCD is running before power is applied. For this reason, the LCD's power on control is not set to "1" unless both LcdEn and LcdPwr are set to "1". Note that most LCD displays require the LcdEn must be set to "1" approximately 20ms before LcdPwr is set to "1" for powering up. Likewise, LcdPwr is set to "0" 20ms before LcdEn is set to "0" for powering down.

0x80010000						
						24
						LDbusEn
23	22	21		19	18	
LcdBLE	LcdPwr	LcdMono8		LcdVComp		
			12			
			BGR			

			4	3	2	1	0	
			LcdTFT	LcdBW	LcdBpp		LcdEn	
Bits	Type	Function						
31:25	-	Reserved						
24	R/W	LD data bus Enable 0 – LD data bus disable (initial value) 1 – LD data bus Enable						
23	R/W	Lcd Backlight enable This drives "0" or "1" out to the Lcd backlight enable pin						
22	R/W	Lcd power enable 0 - Lcd is off 1 - Lcd is on when LcdEn=1						
21	R/W	Lcd monochrome data width 0 - 4 bits Lcd module 1 - 8 bits Lcd module						
20	-	Reserved						
19:18	R/W	Generate interrupt at: 00 - start of VSync 01 - start of BACK PORCH 10 - start of ACTIVE VIDEO 11 - start of FRONT PORCH						
17:13	-	Reserved						
12	R/W	0 - RGB normal video output for LCD 1 - BGR red and blue swapped for LCD						
11:5	-	Reserved						
4	R/W	LCD TFT 0 - Passive or STN display operation enabled 1 - Active or TFT display operation enabled						
3	R/W	LCD Monochrome 0 - Color operation enabled 1 - Monochrome operation only enabled						
2:1	R/W	LCD Bits Per Pixel 00 - 4bpp 01 - 8bpp 10 - 16bpp 11 – Reserved						
0	R/W	LCD Controller Enable 0 - LCD controller disabled 1 - LCD controller enabled						

8.2.2 LCD Controller Status/Mask and Interrupt Registers

The LCD controller status, mask and interrupt registers all have the same format. Each bit of the status register is a status bit that may generate an interrupt. The corresponding bits in the mask register mask the interrupt. The interrupt register is the logical AND of the status and mask registers, and the interrupt output from the LCD controller is the logical OR of the bits within the interrupt register.

The LCD controller status register contains bits that signal an under-run error for the FIFO, the DMA next base update ready status, and the DMA done status. Each of these hardware-detected events can generate an interrupt request to the interrupt controller.

			0x80010004 ~ 0x800100c			
			3	2	1	0
			LDone	VComp	LNext	LFUF
Bits	Type	Function				
31:4	-	Reserved				
3	R	LCD Done frame status/mask/interrupt bit The LCD Frame Done (Done) is a read-only status bit that is set after the LCD has been				

		disabled (LcdEn = 0) and the frame that is current active finishes being output to the LCD's data pins. It is cleared by writing the base address (LcdDBAR) or enabling the LCD, or, by writing "1" to the LDone bit of the Status Register. When the LCD is disabled by clearing the LCD enable bit (LcdEn=0) in LcdControl, the LCD allows the current frame to complete before it is disabled. After the last set of pixels is clocked out onto the LCD's data pins by the pixel clock, the LCD is disabled and Done is set.
2	R/W	Vertical compare interrupt This bit is set when the Lcd timing generator reaches the vertical region programmed in the Video Control Register. This bit is "sticky", meaning it remains set until it is cleared by writing a "1" to this bit
1	R	LCD Next base address update status/mask/interrupt bit The LCD Next Frame (LNext) is a read-only status bit that is set after the contents of the LCD DMA base address register are transferred to the LCD DMA current address register at the start of frame, and it is cleared when the LCD DMA base address register is written.
0	R/W	FIFO underflow status/mask/interrupt bit The LCD FIFO underflow (LFUF) status bit is set when the LCD FIFO under-runs. The status bit is "sticky", meaning it remains set after the FIFO is no longer underrunning. The status bit is cleared by writing a `1' to this bit.

8.2.3 LCD DMA Base Address Register

The LCD DMA base address register (LcdDBAR) is a read/write register used to specify the base address of the off-chip frame buffer for the LCD. Addresses programmed in the base address register must be aligned on sixteen-word boundaries, thus the least significant six bits (LcdDBAR [5:0]) must always be written with zeros. Only 26 bits of the register are valid (including the LS 6 bits which must be zero), because LCD DMA is only allowed from SDRAM.

The 26 bits address range allows the LCD DMA to access any address within the SDRAM. The upper address lines are not needed, because these are the address lines used to select which device is accessed, but the LCD always accesses SDRAM. The user must initialize the base address register before enabling the LCD, and may also write a new value to it while the LCD is enabled to allow a new frame buffer to be used for the next frame. The user can change the state of LcdDBAR while the LCD controller is active, after the Next Frame (Next) status bit is set within the LCD's status register that generates an interrupt request. This status bit indicates that the value in the base address pointer has been transferred to the current address pointer register and that it is safe to write a new base address value. This allows double-buffered video to be implemented if required.

0x80010010

Bits	Type	Function
31:26	-	Reserved. Keep these bits zero
25:6	R/W	LcdDBAR : LCD DMA Channel Base Address Pointer 16-word aligned base address in SDRAM of the frame buffer within off-chip memory.
5:0	-	Reserved. Keep these bits zero

8.2.4 LCD DMA Channel Current Address Register

This read-only register allows the processor to read the current value of the LCD DMA channel current address register. This is not something that would normally be done, but it allows additional test observability. Its value cannot be expected to be exact, it could change at an moment. However, its contents can be read to determine the approximate line that the LCD controller is currently displaying and driving out to the display

0x80010014

Bits	Type	Function
31:26	-	Reserved. Keep these bits zero
25:6	R/W	LcdDCAR : LCD DMA Channel Current Address Pointer 16-word aligned current address pointer to data in SDRAM frame buffer currently being displayed
5:0	-	Reserved. Keep these bits zero

8.2.5 LCD Timing 0 Register

LCD Timing 0 Register (LcdTiming0) controls horizontal LCD timing. See 8.6.2 Pixel Clock Divider (PCD) on

page 8-13 for a description of the terms "PixelClock" and "LcdClk"

0x80010020

31	30	29	28	27	26	25	24	23	22	21	20	19	18	17	16
HBP								HFP							
15	14	13	12	11	10	9	8	7	6	5	4	3	2		
HSW								PPL							

Bits	Type	Function
31:24	R/W	Horizontal Back Porch The 8-bit Horizontal Back Porch (HBP) field is used to specify the number of pixel clock periods to insert at the beginning of each line or row of pixels. After the line clock for the previous line has been negated, the value in HBP is used to count the number of pixel clocks to wait before starting to output the first set of pixels in the next line. HBP generates a wait period ranging from 1-256 pixel clock cycles (Number of LcdClk clock periods to add to the beginning of a line transmission before the first set of pixels is output to the display minus 1).
23:16	R/W	HFP Horizontal Front Porch The 8-bit Horizontal Front Porch (HFP) field is used to specify the number of pixel clock periods to insert at the end of each line or row of pixels before pulsing the line clock pin. Once a complete line of pixels is transmitted to the LCD driver, the value in HFP is used to count the number of pixel clocks to wait before pulsing the line clock. HFP generates a wait period ranging from 1-256 pixel clock cycles. (Program to value required minus one).
15:8	R/W	Horizontal Sync Pulse Width The 6-bit horizontal sync pulse width (HSW) field is used to specify the pulse width of the line clock in passive mode, or horizontal synchronization pulse in active mode. Number of LcdClk clock periods to pulse the line clock at the end of each line minus 1
7:2	R/W	The pixels-per-line (PPL) bit-field is used to specify the number of pixels in each line or row on the screen. PPL is a 6-bit value that represents between 16-1024 pixels per line. PPL is used to count the correct number of pixel clocks that must occur before the line clock can be pulsed. Program the value required divided by 16, minus 1.
1:0	-	Reserved

8.2.6 LCD Timing 1 Register

LCD Timing 1 Register (LcdTiming1) controls LCD vertical timing parameters.

0x80010024

31	30	29	28	27	26	25	24	23	22	21	20	19	18	17	16
VBP								VFP							
15	14	13	12	11	10	9	8	7	6	5	4	3	2	1	0
VSW								LPS							

Bits	Type	Function
31:24	R/W	Vertical Back Porch The 8-bit Vertical Back Porch (VBP) field is used to specify the number of line clocks to insert at the beginning of each frame, i.e. number of inactive lines at the start of a frame, after VSync period. The VBP count starts just after the VSync signal for the previous frame has been negated for active mode, or the extra line clocks have been inserted as specified by the VSW bit-field in passive mode. After this has occurred, the value in VBP is used to count the number of line clock periods to insert before starting to output pixels in the next frame. VBP generates from 0-255 extra line clock cycles. This should be programmed to zero in passive mode, unless sensing LCD to VGA to share DMA data
23:16	R/W	Vertical Front Porch The 8-bit Vertical Front Porch (VFP) field is used to specify the number of line clocks to insert at the end of each frame, i.e. number of inactive lines at the end of frame, before VSync period. Once a complete frame of pixels is transmitted to the LCD display, the value in VFP is used to count the number of line clock periods to wait. After the count has elapsed the VSync (LcdFP) signal is pulsed in active mode, or extra line clocks are inserted as specified by the VSW bit-field in passive mode. VFP generates from 0-255 line clock cycles. This should be zero for passive display modes, unless synchronizing to the VGA to share data.

15:10	R/W	Vertical Sync Pulse Width The 6-bit vertical sync pulse width (VSW) field is used to specify the pulse width of the vertical synchronization pulse in active mode, or is used to add extra dummy line clock delays between frames in passive mode. Should be small for passive LCD, but should be long enough to re-program the video palette under interrupt control, without writing the video palette at the same time as video is being displayed. The register is programmed with the number of lines of VSync minus one.
9:0	R/W	Lines Per Screen The Lines Per Screen (LPS) bit-field is used to specify the number of lines or rows per LCD panel being controlled. LPS is a 10-bit value that represents 1-1024 Lines Per Screen. The register is programmed with the number of lines per screen minus 1.

8.2.7 LCD Timing 2 Register

LCD Timing 2 Register (LcdTiming2) controls various functions associated with the timing of the LCD controller.
0x80010028

				27	26	25	24	23	22	21	20	19	18	17	16
				Skip4	BCD	CPL									
15	14	13	12	11	10	9	8	7	6	5	4	3	2	1	0
SLV	IEO	IPC	IHS	IVS	ACB					LCS	PCD				

Bits	Type	Function
31:28	-	Reserved
27	R/W	Set this bit to "1" when running a color passive LCD with slave mode. This produces an irregular clock to the LCD, where every fourth clock pulse is suppressed (the clock stays LOW for one clock period). This is necessary because two-and-two-third pixels per clock, which are sent to the LCD, is not an integer multiple. This means that three clocks will be output every four-clock period. If PCD is zero, then eight pixels will be output every eight LcdClk periods, since the LCD CP clock will be half the frequency of LcdClk.
26	R/W	Bypass Pixel Clock Divider Setting this bit allows an undivided LCD clock to be output on LCD. This bit could only be set for TFT mode but not in normal cases.
25:16	R/W	Clocks Per Line This is the actual number of clocks output to the LCD panel each line, minus one. This must be programmed, in addition to the PPL field in the LCD Timing 0 Register. The number of clocks per line is the number of pixels per line divided by 1, 4, 8 or two-and-two-thirds for TFT mode, mono 4-bit mode, mono 8-bit, or color STN mode (22/3) respectively.
15	R/W	Slave mode Slave (or genlock) LCD to VGA video. The HSync and VSync are locked to the VGA timing generator. The LCD horizontal timing must be carefully programmed if sharing DMA data
14	R/W	Invert Output Enable The Invert Output Enable (IEO) bit is used to select the active and inactive state of the output enable signal in active display mode. In this mode, the AC-bias pin is used as an enable that signals the off-chip device when data is actively being driven out using the pixel clock. When IEO=0, the LcdAC pin is active HIGH. When IEO=1, the LcdAC pin is active LOW. In active display mode, data is driven onto the LCD's data lines on the programmed edge of LcdCP when LcdAC is in its active state. 0 - LcdAC pin is active HIGH in TFT mode 1 - LcdAC pin is active LOW in TFT mode
13	R/W	Invert Pixel Clock The Invert Pixel Clock (IPC) bit is used to select which edge of the pixel clock pixel data is driven out onto the LCD's data lines. When IPC=0, data is driven onto the LCD's data lines on the rising-edge of LcdCP. When IPC=1, data is driven onto the LCD's data lines on the falling-edge of LcdCP. 0 - Data is driven on the LCD's data lines on the rising-edge of LcdCP. 1 - Data is driven on the LCD's data lines on the falling-edge of LcdCP.
12	R/W	Invert Hsync The Invert HSync (IHS) bit is used to invert the polarity of the LcdLP signal. 0 - LcdLP pin is active HIGH and inactive LOW.

		1 - LcdLP pin is active LOW and inactive HIGH.
11	R/W	Invert Vsync The Invert VSync (IVS) bit is used to invert the polarity of the LcdFP signal. 0 - LcdFP pin is active HIGH and inactive LOW. 1 - LcdFP pin is active LOW and inactive HIGH.
10:6	R/W	AC Bias Pin Frequency The 5-bit AC-bias frequency (ACB) field is used to specify the number of line clock periods to count between each toggle of the AC-bias pin (LcdAC). This pin is used to periodically invert the polarity of the power supply to prevent DC charge build-up within the display. The value programmed is the number of lines between transitions, minus 1. Note The ACB bit field had no effect on LcdAC in active mode. The pixel clock transitions continuously in active mode and the AC Bias line is used as an output enable signal
5	R/W	LCD Clock source selection 0 - DMA bus clock (system bus clock) 1 - Video PLL clock (VCLK; in normal operation)
4:0	R/W	Pixel Clock Divisor Used to specify the frequency of the pixel clock based on the LCD clock (LcdCLK) frequency. Pixel clock frequency can range from LcdCLK/2 to LcdCLK/33, where LcdClk is the clock selected by LCS. Pixel Clock Frequency = LcdCLK/(PCD+2). Note that in the case of the LCD, the pixel clock is not the frequency of some nominal clock rate that individual pixels are output to the LCD. It is the frequency of the LcdCP signal. In normal mono mode (4-bit interface), four pixels are output per LcdCP cycle, so the PixelClock is one quarter the nominal pixel rate. In the case of 8-bit interface mono, PixelClock is one-eighth the nominal pixel rate, since 8 pixels are output per LcdCP cycle. In the case of color, PixelClock is 0.375 times the nominal pixel rate, because 22/3 pixels are output per LcdCP cycle. If the LCD and VGA are operating concurrently, and sharing DMA data, then in color mode the pixel clock should normally be 3/8 the VGA clock. To achieve this, PCD should be 7programmed to the value 0 and the skip4 bit set to "1". The skip4 bit produces a null clock cycle (no high phase) every fourth clock cycle.

8.2.8 LCD Test Register

The LCD test register contains bits that allow certain LCD signals to be output on the LCD pins for test purposes. This register should not normally be used. The register is reset to all zero, and this will result in normal operation.

0x80010040

							8
							TCOUNT
7	6	5	4	3	2	1	0
TCC	TLC	TCR	TLR	TCF	TRF	TLDATA	TEST MODE

Bits	Type	Function
31:9	-	Reserved
8	R/W	Separates the 10-bit counter into nibbles for the test purpose
7	R/W	For production test of grayscale, never write a "1" to these registers in normal use.
6	R/W	For production test of grayscale, never write a "1" to these registers in normal use.
5	R/W	For production test of grayscale, never write a "1" to these registers in normal use.
4	R/W	For production test of grayscale, never write a "1" to these registers in normal use.
3	R/W	For production test of grayscale, never write a "1" to these registers in normal use.
2	R/W	For production test of grayscale, never write a "1" to these registers in normal use.
1	R/W	Walking one's pattern used in place of SDRAM data for the LCD controller
0	R/W	Test mode bit for grey-scaler

8.2.9 Grayscale Test Registers

The registers GSFrame State, GSRow State and GS Column State are used for the purpose of production test

and **must not** be written to or read from in normal use.

0x80010044, 0x80010048, 0x8001004c

8.2.10 LCD Palette registers

The LCD palette registers are a set of 256 word-aligned registers that allow the LCD to be programmed. The format of the palette data is shown below. At the TFT mode, the palette RAM bit width will be increased as Figure 8-6.

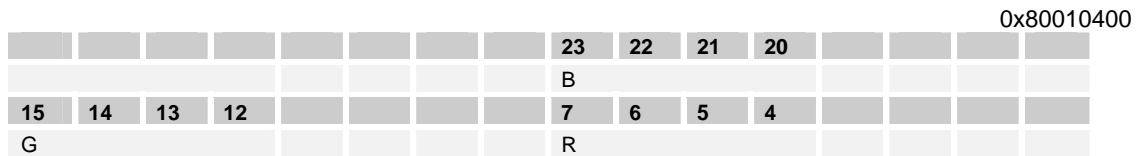

Figure 8-5 LCD Palette Word Bit Field for STN mode

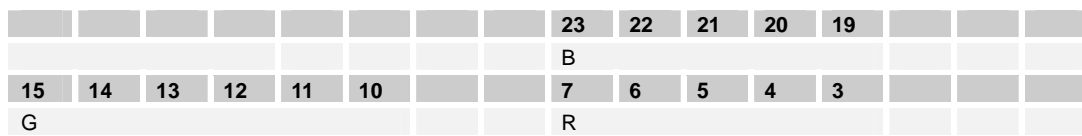

Figure 8-6 LCD Palette Word Bit Field for TFT mode

8.3 Timings

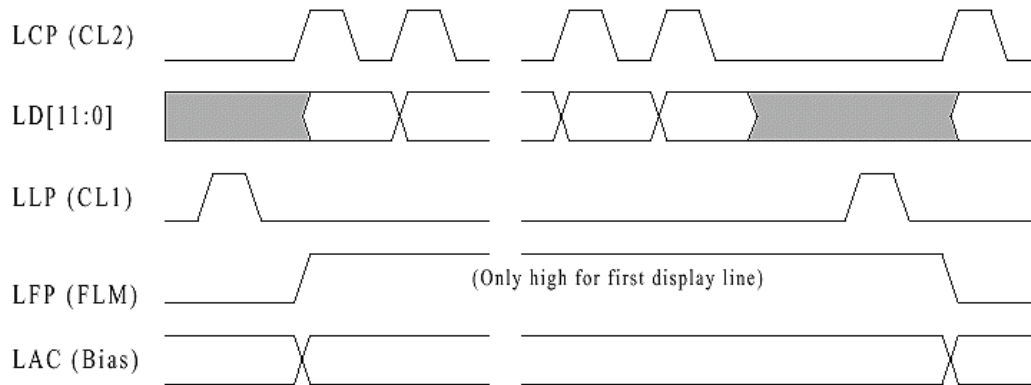

Figure 8-7 Example Mono STN LCD Panel Signal Waveforms

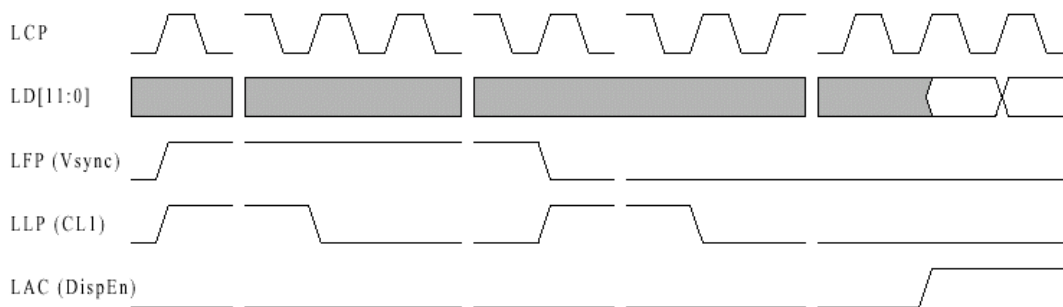

Figure 8-8 Example TFT Signal Waveforms, Start of Frame

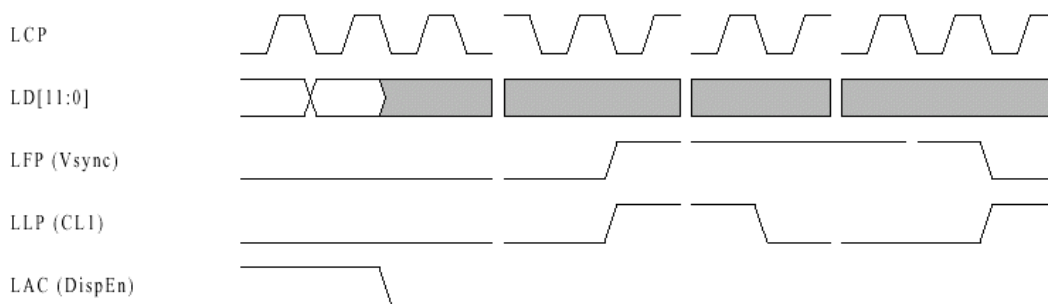

Figure 8-9 Example TFT Signal Waveforms, End of Last Line

9 FAST AMBA PERIPHERALS

9.1 DMA Controller

This chip includes a three-channel direct memory access controller (DMAC). High-speed transfers between peripheral devices and the SDRAM can be controlled by the DMAC instead of the CPU core. Transfers using addresses other than SDRAM will produce unpredictable results.

Features

- Three Channels.
- Max Transfer rate: 133MB/s.
- Max Buffer size: 16383.
- Address mode: Single(SDRAM) address is supported.
- Channel function: Transfer modes are different in each channel.
 - i. **Channel 0:** Dedicated to the sound interface controller. This channel has a source address reload function. The memory space of the sound I/O device consists of a double buffer. The sound interface uses exception bus mode and word access. The channel performs only DMA transfers for transmitting data (transfers from SDRAM to the sound interface).
 - ii. **Channel 1:** Dedicated to the SMC/MMC interface block. The channel uses exception bus mode and word access. It controls DMA transfers for both transmitting (from SDRAM) and receiving (to SDRAM). Word is the only supported transfer size. Correct DMA operation of this channel is guaranteed only if the SDRAM write buffer is enabled and LCD operation is disabled. Otherwise it will produce unpredictable results.
 - iii. **Channel 2:** Used by external IO device. The channel supports both exception and burst bus modes. Transfer sizes of byte, half word (16 bits) and word are all supported.
- Channel priority: Configured by register setting.
- Interrupt request: The DMAC interrupt request can be triggered by each channel whenever the DMA transfer is completed by buffer size. Since only one interrupt ID is assigned to the DMAC, the interrupt flag register (FLAGR) maintains the information on which DMA channel requested the interrupt.
- The channel 2 should not be enabled with either of the other channels at the same time.

9.1.1 External Signals

Pin Name	Type	Description
nDMAREQ	I	DMA request input signal from external device (level sensitive, active Low)
nDMAACK	O	DMA acknowledge output signal to external Device.

9.1.2 Registers

Address	Name	Width	Default	Description
0x8000.4000	ADR0	32	0x0	Write: Start address of the first buffer of Channel 0 Read: Current address of the first buffer of Channel 0
0x8000.4004	ASR	32	0x0	Write: Start address of the second buffer of Channel 0 Read: Current address of the second buffer of Channel 0
0x8000.4008	TNR0	14	0x3FFF	Write: Size of the first buffer of Channel 0 (in words) Read: Number of words in the first buffer of Channel 0 which remain to be transferred
0x8000.400C	TSR	14	0x3FFF	Write: Size of the second buffer of Channel 0 (in words) Read: Number of words in the second buffer of Channel 0 which remain to be transferred
0x8000.4010	CCR0	4	0x0	Channel 0 control
0x8000.4014	ADR1	32	0x0	Write: Start address of Channel 1 buffer Read: Current address of Channel 1 buffer
0x8000.4018	TNR1	14	0x3FFF	Write: Size of Channel 1 buffer (in words) Read: Number of words in Channel 1 buffer which remain to be transferred

0x8000.401C	CCR1	3	0x0	Channel 1 control
0x8000.4020	ADR2	32	0x0	Write: Start address of Channel 2 buffer Read: Current address of Channel 2 buffer
0x8000.4024	TNR2	14	0x3FFF	Write: Size of Channel 2 buffer (in unit of transfer size). Read: Number of data in Channel 2 buffer which remain to be transferred (in unit of transfer size)
0x8000.4028	CCR2	8	0x0	Channel 2 control
0x8000.4038~ 0x8000.4040	-	-	-	Reserved
0x8000.4044	FLAGR	5	0x0	DMA interrupt flags
0x8000.4048~ 0x8000.4050	-	-	-	Reserved
0x8000.4054	DMAOR	3	0x0	Operation control of the DMAC

Table 9-1 DMA Controller Register Summary
9.1.2.1 ADR0

			0x8000.4000
31	30	29	...
			2
			1
			0
ADR0			
Bits	Type	Function	
31:0	R/W	Write: Start address of the first buffer (Buffer 0) of Channel 0 (for the sound interface) Read: Current address of the first buffer of Channel 0	

9.1.2.2 ASR

			0x8000.4004
31	30	29	...
			2
			1
			0
ASR			
Bits	Type	Function	
31:0	R/W	Write: Start address of the second buffer (Buffer 1) of Channel 0 Read: Current address of the second buffer of Channel 0	

9.1.2.3 TNR0

			0x8000.4008
-	13	12	...
			1
			0
Reserved			
TNR0			
Bits	Type	Function	
13:0	R/W	Write: Size of the first buffer of Channel 0 (in words, max. 16383) Read: Number of words in the first buffer of Channel 0 which remain to be transferred	

9.1.2.4 TSR

			0x8000.400C
-	13	12	...
			1
			0
Reserved			
TSR			
Bits	Type	Function	
13:0	R/W	Write: Size of the second buffer of Channel 0 (in words, max. 16383) Read: Number of words in the second buffer of Channel 0 which remain to be transferred	

9.1.2.5 CCRO

			0x8000.4010
-	2	1	0
		MASK01	MASK00
		DMEN0	
Reserved			
Bits	Type	Function	

2	R/W	Buffer 1 transfer end interrupt mask bit of Channel 0 1 = Interrupt request is generated when the whole DMA transfer of Buffer 1 is completed. 0 = No Interrupt request is generated when the whole DMA transfer of Buffer 1 is completed.
1	R/W	Buffer 0 transfer end interrupt mask bit of Channel 0 1 = Interrupt request is generated when the whole DMA transfer of Buffer 0 is completed. 0 = No Interrupt request is generated when the whole DMA transfer of Buffer 0 is completed.
0	R/W	Channel 0 enable bit 1 = Channel 0 is enabled. 0 = Channel 0 is disabled.

9.1.2.6 ADR1

				0x8000.4014		
31	30	29	...	2	1	0
ADR1						
Bits	Type	Function				
31:0	R/W	Write: Start address of Channel 1 buffer (for SMC/MMC) Read: Current address of Channel 1 buffer				

9.1.2.7 TNR1

				0x8000.4018		
-	13	12	...	1	0	
Reserved				TNR1		
Bits	Type	Function				
13:0	R/W	Write: Size of Channel 1 buffer (in words, max. 16383) Read: Number of words in Channel 1 buffer which remain to be transferred				

9.1.2.8 CCRI

				0x8000.401C		
-	2	1	0			
Reserved				MASK1	MODE1	DMEN1
Bits	Type	Function				
2	R/W	Transfer end interrupt mask bit of Channel 1 1 = Interrupt request is generated when the DMA transfer of the whole buffer is completed. 0 = No Interrupt request is generated when the DMA transfer of the whole buffer is completed.				
1	R/W	Transfer direction 0 = Transfer from SDRAM to SMC/MMC 1 = Transfer from SMC/MMC to SDRAM				
0	R/W	Channel 1 enable bit 1 = Channel 1 is enabled. 0 = Channel 1 is disabled.				

9.1.2.9 ADR2

				0x8000.4020		
31	30	29	...	2	1	0
ADR2						
Bits	Type	Function				
31:0	R/W	Write: Start address of Channel 2 buffer (for external I/O device) Read: Current address of Channel 2 buffer				

9.1.2.10 TNR2

				0x8000.4024		
-	13	12	...	1	0	
Reserved				TNR2		

Bits	Type	Function
13:0	R/W	Write: Size of Channel 2 buffer (in unit of transfer size, max. 16383) Read: Number of data in Channel 2 buffer which remain to be transferred (in unit of transfer size)

9.1.2.11 CCR2

0x8000.4028

-	8	7	6	5	4	3	2	1	0
Reserved	ISA	BURST		TYPE	SIZE		MASK2	MODE2	DMEN2

Bits	Type	Function
8	R/W	External bus type 0: not ISA type (Default) 1: ISA type
7:6	R/W	Burst length 11: 32 beats 10: 16 beats 01: 8 beats 00: 4 beats
5	R/W	Transfer type 0: exception mode 1: burst mode
4:3	R/W	Transfer size 11: reserved 10: word 01: half word 00: byte
2	R/W	Transfer end interrupt mask bit of Channel 2 1 = Interrupt request is generated when the DMA transfer of the whole buffer is completed. 0 = No Interrupt request is generated when the DMA transfer of the whole buffer is completed.
1	R/W	Transfer direction 0 = Transfer from SDRAM to external I/O 1 = Transfer from external I/O to SDRAM
0	R/W	Channel 2 enable bit 1 = Channel 2 is enabled. 0 = Channel 2 is disabled.

* Note: The burst mode must be used in the external bus type of ISA

9.1.2.12 FLAGR

0x8000.4044

-	3	2	1	0
Reserved	FLAG2	FLAG1	FLAG01	FLAG00

Bits	Type	Function
3	R/W	Interrupt flag of Channel 2 Set when the whole transfer of Channel 2 buffer is completed. If MASK2 (Bit 2 of CCR2) is set, there is an interrupt request.
2	R/W	Interrupt flag of Channel 1 Set when the whole transfer of Channel 1 buffer is completed. If MASK1 (Bit 2 of CCR1) is set, there is an interrupt request.
1	R/W	Interrupt flag of the first buffer of Channel 0 Set when the whole transfer of the first buffer of Channel 0 is completed. If MASK01 (Bit 2 of CCR0) is set, there is an interrupt request.
0	R/W	Interrupt flag of the second buffer of Channel 0 Set when the whole transfer of the second buffer of Channel 0 is completed. If MASK00 (Bit 1 of CCR0) is set, there is an interrupt request.

Note: Each flag bit is cleared by writing '1' to its bit position.

9.1.2.13 DMAOR

0x8000.4054

-	2	1	0
Reserved	PRMD	DMAEN	

Bits	Type	Function
2:1	R/W	Defines the channel priorities in case of simultaneous transfer requests for multiple channels. 11: ch0 > ch1 > ch2 10: ch2 > ch1 > ch0 01: ch1 > ch0 > ch2 00: ch1 > ch2 > ch0 (initial value)

0	R/W	DMA operation enable bit 1 = DMA operation is enabled. 0 = DMA operation is disabled. A specific DMA channel is enabled when both of this bit and the corresponding channel enable bit (DMENx) are set.
---	-----	--

9.1.3 DMAC operation

For correct DMA operation, the DMA address register (ADR_x or ASR), DMA buffer size register (TNR_x), DMA channel control register (CCR_x), and DMA operation register (DMAOR) must be set properly. Then the DMAC performs DMA data transfers as follows.

- The DMAC checks if the corresponding channel enable bit (DMEN_x, Bit 0 of CCR_x) and the DMAEN (Bit 0 of DMAOR) are enabled.
- When there is a transfer request from internal or external I/O and the DMA transfer in the corresponding channel is enabled, the DMAC initiates DMA data transfers according to the bus size, transfer direction and bus mode.
- The DMAC ends data transfers and sets the corresponding interrupt flag (FLAG_x of FLAGR) when the whole buffer is transferred (when the internal count value equals TNR_x or TSR). If the interrupt mask bit of the channel is set (and the DMA interrupt is enabled in the interrupt controller), a DMA transfer end interrupt request is sent to the CPU core.

DMA Channel Priority

When the DMAC receives simultaneous DMA transfer requests, the channel with the higher priority is served first. The channel priorities are programmable in the DMAOR register.

DMA bus mode

Burst mode (for Channel 2)

Once the bus mastership is obtained, the transfer is performed continuously by the burst length (BURST, Bit 7 of CCR2) as long as nDMAREQ pin is driven high. Then the bus mastership is given to the CPU.

Exception mode (cycle-steal mode)

In the exception mode, the bus mastership is given to the CPU core whenever one transfer is completed

DMA transfer request

The DMA transfer request should be disabled by I/O device module.

9.2 MMC/ SPI Controller

The SPI is a high-speed synchronous serial port. This chapter describes the SPI communication with a MMC device.

The communication between CP (master) and MMC is controlled by the CP. The data transmission starts when the CS (chip-select) goes LOW and ends when the CS goes HIGH.

SPI-MMC messages are built from command, response and data-block tokens. Every command, response and data block is built with one byte (8-bit). Generally every MMC token transferred on the data signal is protected by CRC bits. But MMC offers also a non-protected mode that allows a system, built with reliable data links to exclude the hardware or firmware required for CRC generation and verification.

In the non-protected mode, the CRC bits of the command, response and data tokens are still required in the tokens; they are, however, defined as "don't care" for the transmitters and are ignored by the receivers.

MMC is initialized in the non-protected mode. The CP can turn this option on and off using the CRCONOFF command (CMD39). We assume that CRC is processed by software.

9.2.1 External Signals

Pin Name	Type	Description
SSDO	O	MMC card controller data output
SSDI	I	MMC card controller data input
SSCLK	O	MMC card controller clock output
nSSCS	O	MMC card controller chip select

9.2.2 Registers (SPI Mode)

Address	Name	Width	Default	Description
0x8001.5000	SPICR	0x20		SPI control register
0x8001.5004	SPISR	0x0		SPI status register
0x8001.5008	XCHCNT	0x0		Number of exchange data
0x8001.500C	TXBUFF	0x0		TX data buffer (8*8 bits)
0x8001.5010	RXBUFF	0x0		RX data buffer (8*8 bits)
0x8001.5014	TestReg1	0x0		Test register 1
0x8001.5018	TestReg2	0x0		Test register 2
0x8001.501C	ResetReg	0x0		SPI reset register
0x8001.5024	TicReg	0x0		Tic register

Table 9-3 SPIMMC Controller Register Summary

9.2.2.1 SPIMMC Control Register (SPICR)

0x8001.5000							
	6	5	4	3	2	1	0
	DataRate	CS	XCHMode	TestMode	LOOP	SPIEN	XCH
Bits	Type	Function					
7	-	Reserved					
6	R/W	This bit sets the baud rate (SPICLK) 0 : SPICLK=BCLK/2 1 : SPICLK=BCLK/4					
5	R/W	This bit is the Chip select signal. To communicate with external devices (MMC), CP asserts 0 in this bit. 0 = CP can exchange data with external device (MMC) 1 = CP cannot exchange data with external device (MMC)					
4	R/W	This bit determines the direction of transfer 0 = CP have valid data to send to MMC (send mode) 1 = CP have valid data to receive from MMC (receive mode)					
3	R/W	0 = Normal operation 1 = the SPI-MMC block is in TIC mode. In this mode the Clock source is not BCLK/2 but TCLK that is made in the block.					

2	R/W	0 = Normal operation 1 = The SPI-MMC block is in loopback mode. In the loopback mode the transmitter output is internally connected to the receiver input. MISO is internally connected to MOSI.
1	R/W	0 = SPI master disable (reduce power consumption) 1 = SPI master enable The SPI must be enabled before initiating an exchange and should be disabled after the exchange is complete to reduce the power consumption.
0	R/W	This bit triggers the state machine to generate clocks at the selected bit rate. 1 = Initiate exchange 0 = No exchange occurs

9.2.2.2 SPIMMC Status Register (SPISR)

0x8001.5004

7	6	5							
TXET	XCHDONE	RXFULL							

Bits	Type	Function
7	R	When the TX data buffer is empty this bit is set and a serial peripheral interrupt is generated. The bit is reset by reading the SPISR.
6	R	When the exchange is completed between CP and MMC this bit is set and a serial peripheral interrupt is generated. The bit is reset by reading the SPISR.
5	R	When the RX data buffer is full this bit is set and a serial peripheral interrupt is generated. The bit is reset by reading the SPISR.
4:0	-	Reserved

9.2.2.3 SPIMMC XCH Counter Register (XCHCNT)

0x8001.5008

9	8	7	6	5	4	3	2	1	0
XCH COUNTER									

Bits	Type	Function
9:0	R/W	Number of bytes to be exchanged between CP and SPI

9.2.2.4 SPIMMC TX Data Buffer Register (TXBUFF)

0x8001.500C

This 8-bit register is the entry point of the TX FIFO. When CP writes an 8-bit data to this register, the SPI-MMC block shifts the content of the TX FIFO and appends the new data to the FIFO.

7	6	5	4	3	2	1	0
TX FIFO ENTRY POINT							

Bits	Type	Function
7:0	W	TX FIFO's Entry Point

9.2.2.5 SPIMMC RX Data Buffer Register (RXBUFF)

0x8001.5010

This register is the access point of the RX FIFO. When CP reads one data item from this register, the SPI-MMC block shifts the RX FIFO so that the next data item becomes available at this location.

7	6	5	4	3	2	1	0
RX FIFO ACCESS POINT							

Bits	Type	Function
7:0	R	RX FIFO's Access Point

9.2.2.6 SPIMMC Reset Register (ResetReg)

							0x8001.501C
							0
							RESET

Bits	Type	Function
7:1	-	Reserved
7:0	R/W	When CP writes 0 to this location, all registers and counters of the SPI-MMC block are cleared.

9.2.3 Timings

All timing diagrams use the following schematics and abbreviations.

Name	Description	Name	Description
H	Signal is HIGH (logic 1)	Busy	Busy token
L	Signal is LOW (logic 0)	Command	Command token
X	Don't care	Response	Response token
Z	High Impedance State	DataBlk	Data token
*	Repeater		

All timing values are defined as outlined below.

Command/Response

Host command to card response: card is ready

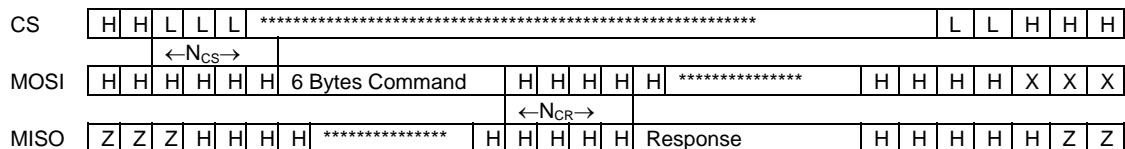

Host command to card response: card is busy

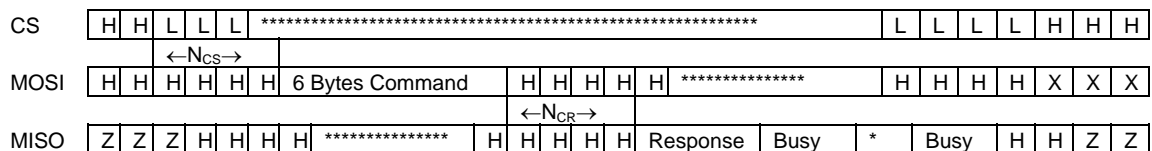

Card response to host command:

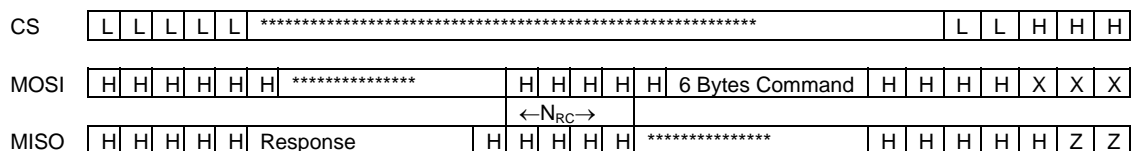

Data read

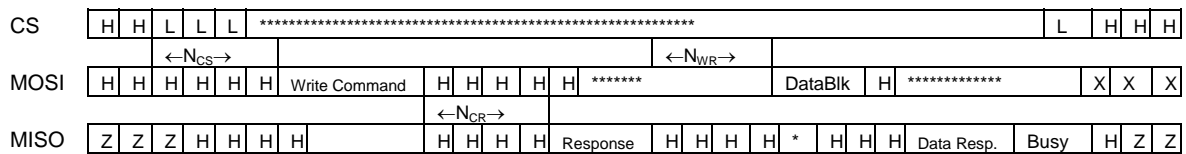

Data write

Timing constants definitions

Name	Minimum	Maximum	Unit
N _{CS}	0	-	8 Clock Cycles
N _{CR}	1	2	8 Clock Cycles
N _{RC}	1	-	8 Clock Cycles
N _{AC}	1	-	8 Clock Cycles
N _{WR}	1	-	8 Clock Cycles

9.2.4 SPI Operation for MMC

After CP writes a sequence of data to the TX FIFO, the content of the FIFO is loaded into the TX shift register and shifted out serially one byte at a time. When all elements in the TX FIFO are transferred to the TX shift register, the SPI-MMC issues an interrupt to CP, which may fill the TX FIFO for further data transfer.

Serial input data is shifted into the RX shift register. After 8 bits are shifted in, the content of the RX shift register is copied into the RX FIFO. When the RX FIFO is full, the SPI-MMC issues an interrupt to CP through the SPIIRQ signal. CP reads the content of the RX FIFO in an interrupt service routine.

The timing and control block produces all necessary control signals of the SPI-MMC block including SPICLK. The frequency of SPICLK signal is programmable.

SPI-MMC transfer's protocol is command and response. Whenever CP sends a command to MMC (via SPI), MMC sends CP (via SPI) a response. The length of the response depends on the command – e.g. there are 1-, 6-, and 17-byte responses. There is only 6 bytes in command.

Consider the sequence of operations that occur in a read transfer.

- CP sends a reset signal to the SPI-MMC block. In other word, CP writes "0" to bit in the ResetReg register. The signal is used to clear counters inside the block. Before new exchange begins and the content of XHCOUNTER is changed, and transmit mode is changed (XCHMODE BIT in the SPICR), CP must send a reset signal to the SPI-MMC block.
- First, CP set up the SPICR register. In this example, XCHMODE is send mode.
- CP writes number to send into XHCOUNTER register.
- CP writes "Data read command (CMD17)" into the TX FIFO.
- CP asserts CS signal. In other words, CP write 0 to CS bit in the SPICR.
- CP sends a start signal to SPI-MMC. In other word, CP set XCH bit in the SPICR.
- The SPI-MMC block sends out 6 bytes of command data from TX FIFO through TX shift register.
- The SPI-MMC block issues the interrupt after it send all data in TX FIFO.
- The CP reads the SPISR register in The SPI-MMC block and disable start signal (reset XCH bit). In other words, CP writes the SPICR register.
- CP sends a reset signal to the SPI-MMC block. In other word, CP writes 0 to bit in the ResetReg register. The signal is used to clear counters inside the block. Before new exchange begins and the content of XHCOUNTER is changed, and transmit mode is changed (XCHMODE BIT in the SPICR), CP must send a reset signal to the SPI-MMC block.
- CP changes transmit mode (XCHMODE is receive mode).
- The CP writes number to be received into XHCOUNTER register.
- CP sends a start signal to SPI-MMC (set XCH bit).
- Then SPI-MMC controller receives response from MMC.
- After SPI-MMC receives 1 byte (for CMD17 command), it sets XCH DONE status bits and it issues an interrupt to a CP.
- The CP reads the SPISR register in the SPI-MMC block and disable start signal (reset XCH bit). In other words, CP writes the SPICR register.
- The CP reads data RX FIFO.

18. After CP takes this response data and examine it, CP act as response data. If there is no error indication in response, CP informs SPI-MMC block that MMC sends data to it.
19. CP sends a reset signal to the SPI-MMC block. In other words, CP writes 0 to bit in the Reset register. The signal is used to clear counters inside the block. Before new exchange begins and the content of XCHCOUNTER is changed, and transmit mode is changed (XCHMODE BIT in the SPICR), CP must send a reset signal to the SPI-MMC block.
20. The CP writes number to be received into XCHCOUNTER register.
21. CP sends a start signal to SPI-MMC (set XCH bit).
22. The SPI-MMC block receives data from MMC (for example, data length is from 4 byte to 515 byte).
23. If SPI-MMC receives data like RX FIFO size, SPI-MMC block sets the "RX FIFO full" status bit and issues an interrupt to CP. At this time SPICLK disable start signal for prevention of RX FIFO overrun. If CP takes all data in RX FIFO, CP sends a start signal and receives response to remain. Repeat it.
24. After SPI-MMC block receive all data from MMC, it sets the XCH DONE status bit and issues an interrupt to CP.
25. The CP reads the SPISR register in the SPI-MMC block and disable start signal (reset XCH bit). In other words, CP writes the SPICR register.
26. After CP takes last data from RX FIFO, CP de-asserts CS signal.

9.2.5 Multimedia Card Host Controller

This document will describe the basic operation about the MMC Host controller for the ARM7202. This controller operates in MMC mode to communicate with Multimedia Card.

9.2.6 Registers

The MMC host controller has 12 registers. Following table shows the register map and its reset value.

Address	Name	Width	Default	Description
0x8001.5040	mmcModeReg	9		MMC Mode Register
0x8001.5044	mmcOperationReg	9		MMC Operation Register
0x8001.5048	mmcStatusReg	15		MMC Status Register
0x8001.504C	mmclntrEnReg	7		MMC interrupt Enable Register
0x8001.5050	mmcBlockSizeReg	11		MMC Block Size Register
0x8001.5054	mmcBlockNumberReg	16		MMC Block Number Register
0x8001.5058	mmcTimePeriodReg	24		MMC Time Period Register
0x8001.505C	mmcCMDBufferReg	6		MMC Command Buffer Register
0x8001.5060	mmcARGBufferReg	32		MMC ARG Buffer Register
0x8001.5064	mmcRESPBufferReg	32		MMC RESP Buffer Register
0x8001.5068	mmcDATABufferReg	32		MMC Data Buffer Register
0x8001.507C	mmcReadyTimeoutReg	24		MMC Ready Timeout Register

Table 9-4 MMC Host Controller Register Summary

9.2.6.1 MMC Mode Register

0x8001.5040	8	7	6	5 : 3	2	1	0
	IntrReq	DmaReq	SoftReset	ClkRate	DmaEn	Reserved	Enable

Bits	Type	Function
8	R	Interrupt Request Signal.
7	R	DMA Request Signal.
6	R/W	Software Reset.
5:3	R/W	Clock Rate Divisor Value. BCLK is 50MHz.

MMCCLK speed will be one of these values according to divisor value.

- 0 for 25MHz (1/2 BCLK)
- 1 for 12.5MHz (1/4 BCLK)
- 2 for 6.25MHz (1/8 BCLK)
- 3 for 3.125MHz (1/16 BCLK)

		4 for 1.5625MHz (1/32 BCLK)
		5 for 0.78125MHz (1/64 BCLK)
		6 for 0.390625MHz (1/128 BCLK)
		7 for 0.1953125MHz (1/256 BCLK)
2	R/W	DMA Enable.
1	-	Reserved
0	R/W	MMC Enable.

Table 9-5 MMC Mode Register

MMC Controller can be reset by the two methods. First is the system reset. In this case, most registers are initialized to the default value. But two registers (response FIFO and data FIFO) are not initialized. Second is the software reset. It is accomplished by writing the 7th bit of MMC mode control register with 1. Its effect is same with the first. Following table shows the MMC mode control register.

This controller sends the DMA request signal in two cases (Rx & Tx). And if you want to use DMA, you must set the DmaEn bit of MMC Mode register. For Rx, when the number of data in the FIFO is more then zero, it generates the request signal. For Tx, when the number of data in the FIFO are less then eight, it generate the request signal.

Operation frequency can be controlled by setting the ClkRate bit of MMC Mode register. Divisor controls the rate of MMC clock (MMCCLK). Assume that BCLK has 50MHz frequency.

9.2.6.2 MMC Operation Register

							0x8001.5044
8	7	6	5	4:3	2	1	0
BusyCheck	StreamEn	WriteEn	DataEn	RespFormat	Initialization	ClkEn	StartEn
Bits	Type	Function					
8	R/W	Current command needs the busy check after command operation.					
7	R/W	Define stream mode(1 = stream mode, 0 = block mode)					
6	R/W	1 = write, 0 = read. default is read					
5	R/W	Indicate that current command contains the data operation					
4:3	R/W	Response format (No response, R1, R2, and R3) 0 for No response 1 for format R1 2 for format R2 3 for format R3					
2	R/W	Add the 128 clocks before sending the command					
1	R/W	Enable the clock					
0	R/W/C	Start the mmc operation					

Table 9-6 MMC Operation Register

All Multimedia Cards require at least 74 clock cycles prior to starting bus communication. and the clock frequency must be less then the Open-Drain frequency($F_{od}=0.5\text{Mhz}$). Therefore the host controller must do these during power-on.

For generating 74 clock cycles, set initialization bit of MMC Operation register. If initialization bit is set, then the controller will send additional 128 clocks before send start bit. Although this bit is zero, the controller sends 16 clocks before the start bit for safe operation. And add 8 clocks after the stop bit.

MMC has the four types of the response (No response, R1, R2, and R3). And each format is similar to the command format. But you need not know what they shape. You just only need to know the length of response to be stored after the response end. R1 and R3 have one word. And R2 has four words. Its contents are different according to the each command. You must analysis this content according to the each command after operation. And the response format can be specified by the RespFormat bits of the operation control register.

9.2.6.3 MMC Status Register

							0x8001.5048
14	13	12	11	10	9	8	
Detected_n	DetIntr	ReadyTimeout	RespCrcErr	DataCrcErr	RespTimeout	DataTimeout	
7	6	5	4	3	2	1	
0							

CardBusy	DataOperEnd	DataTransEnd	CmdRespEnd	ClkOnv	RxFifoFull	TxFifoEmpty	RxFifoReady
Bits	Type	Function					
14	R	card detection status					
13	R/WC	card detection interrupt					
12	R/WC	ready timeout error status					
11	R/WC	response data CRC error					
10	R/WC	Rx or Tx data CRC error					
9	R/WC	response timeout error					
8	R/WC	data timeout error					
7	R	card busy status					
6	R/WC	MMC operation status					
5	R/WC	data transfer status for Rx and Tx					
4	R/WC	command response end status					
3	R	clock status					
2	R	Rx FIFO is full					
1	R	Tx FIFO is empty					
0	R	Rx FIFO contains more than the one word					

Table 9-7 MMC Status Register

WC : To clear these bit, you need to write any dummy value to these register.

9.2.6.4 MMC Interrupt Enable Register

							0x8001.504C
6	5	4	3	2	1	0	
mmcDetIntr	croErrIntr	timeoutIntr	OpEndIntr	dataTranfEndIntr	CmdRespEndIntr	dataFifoIntr	
Bits	Type	Function					
6	R/W	Card detection interrupt (insertion, remove). This interrupt can be used to check the card insertion and removal					
5	R/W	CRC errors interrupt (response CRC error, data CRC error). This interrupt is generated in two cases (response CRC error, data CRC error). If CRC interrupt is generated, MMC host controller will stop the current operation.					
4	R/W	Timeout interrupt (Response timeout, data timeout, and ready timeout). MMC host controller generates three types of timeout interrupt (response, data, and busy). These three timeout values are specified in MMC Time Period register and MMC Ready Timeout register. ISR can check the each timeout interrupt by reading MMC Status register.					
3	R/W	Operation end interrupt. This interrupt is generated when all operation is finished. Before the start operation, you need to set MMC Operation register. This register contains information about the operation. If an operation does not need the response and data, this interrupt is generated after the end of command transfer. If an operation just needs response, it is generated when MMC host controller receives the response. If an operation needs the data operation, it is generated when MMC host controller finish all operation including busy checking.					
2	R/W	Data transfer end interrupt. This interrupt is generated when MMC Host controller receives or sends the data specified by MMC Block Size register and MMC Block Number register. In most case, Multimedia Card goes into the ready state to write internal buffer data into flash memory. So after data transfer, Multimedia Card can be ready state for some time. This interrupt can be used to inform the data transfer end without busy check.					
1	R/W	Command response ends interrupt. This interrupt is generated when MMC Host controller finishes receiving of command response. For data read operation, because the response and data is transmitted currently, you can use this interrupt to check the data FIFO and the response FIFO independently.					
0	R/W	Data fifo interrupt (Rx fifo full, Tx fifo empty). This interrupt is generated in two cases (Rx FIFO full, Tx FIFO empty). You can use this interrupt to check the FIFO status during the read and write operation. And by reading the status register, you can know which interrupt is taken.					

Table 9-8 MMC Interrupt Enable Register

MMC Host controller has the seven interrupt sources (Rx/Tx Fifo interrupt, command response interrupt, data transfer end interrupt, MMC operation interrupt, timeout interrupt, CRC error interrupt and MMC detection interrupt). Setting the each interrupt enable bit of MMC Interrupt Enable register can enable each interrupt.

We can consider the card detection in the two cases.

Firstly, In case that MMC Host controller is not enabled, clock is not supplied into the controller. So the detection logic can operate without the clock. To detect the MMC without clock, the detection signal is passed into the interrupt request directly. If the card detection interrupt is enabled, interrupt signal will be passed into the interrupt controller. Secondly, If MMC host controller is enabled; it means the detection logic now operates with clock. In this case, MMC Host controller detects both card insertion and card removal. When this interrupt is generated, you can detect if current interrupt is the card insertion or removal by reading the Detected_n bit of MMC Status register. If the value is zero, it indicates card insertion. If not, it notifies card removal.

9.2.6.5 MMC Block Size Register

10	...	0	0x8001.5050
Max. Block Length			
Bits	Type	Function	
10:0	R/W	Maximum Block Length Definition up to 2048 bytes.	

Table 9-9 MMC Block Size Register

9.2.6.6 MMC Block Number Register

15	...	0	0x8001.5054
Max. Number of Block			
Bits	Type	Function	
15:0	R/W	Maximum Number of Block Transfer Definition up to 64K blocks.	

Table 9-10 MMC Block Number Register

9.2.6.7 MMC Time Period Register

23	...	16	15	...	0	0x8001.5058
RespTimeout			DataTimeout			
Bits	Type	Function				
23:16	R/W	Response Timeout Period				
15:0	R/W	Data Timeout Period				

Table 9-11 MMC Time Period Register

9.2.6.8 MMC Command Buffer Register

5	...	0	0x8001.505C
Command Buffer			
Bits	Type	Function	
5:0	R/W	Command Buffer	

Table 9-12 MMC Command Buffer Register

9.2.6.9 MMC Argument Buffer Register

31	...	0	0x8001.5060
Argument Buffer			
Bits	Type	Function	
31:0	R/W	Argument Buffer	

Table 9-3-6-9 MMC Argument Buffer Register
9.2.6.10 MMC Response Buffer Register

31	...	0	0x8001.5064
Response Buffer			
<hr/>			
Bits	Type	Function	
31:0	RO	Response Buffer	

Table 9-13 MMC Response Buffer Register

This controller has two FIFO, which are response and data FIFO. Each has 4-word depths and 8-word depths. And Both FIFOs are cleared at the start of the command. If there were some data before starting, incorrect data will be transmitted, so you have to confirm that the FIFO is empty to writing any value into the status register. There is no way to write the MMC Resp Buffer directly. This Register can be written only when the Response from MMC Card is received.

For data FIFO, it used two modes. If the current operation is read, it will be used the Rx FIFO, if not, the Tx FIFO.

9.2.6.11 MMC Data Buffer Register

31	...	0	0x8001.5068
Data Buffer			
<hr/>			
Bits	Type	Function	
31:0	R/W	Data Buffer	

Table 9-14 MMC Data Buffer Register
9.2.6.12 MMC Ready Timeout Register

23	...	0	0x8001.507C
ReadyTimeout			
<hr/>			
Bits	Type	Function	
23:0	R/W	Ready Timeout Period	

Table 9-15 MMC Ready Timeout Register
9.2.7 Basic Operation in MMC Mode

MMC command format consists of six parts. Four parts (start bit, transmitter bit, CRC, and stop bit) are automatically generated by MMC Host controller. For remain two parts (command index, argument), you must inform the MMC Host controller by setting registers properly.

After power-on, all Multimedia Cards need at least 74 clock cycles prior to starting the operation. It can be achieved by setting the third bit (Initialization) of the MMC Operation register. If set, MMC Host controller sends 128 clock cycles prior to sending start bit.

In case of data operation, you need to define the type of operation.

For example, at the case of block write, both DataEn and WriteEn are '1'. To enable stream read, both DataEn and StreamEn are '1' while WriteEn is '0'.

For some command, it needs the busy check after the command end. In this case, busy check bit of MMC Operation register is must be set (For more details, refer to "Multimedia Card Product Manual").

Finally, to initiate operation, write '1' to StartEn and ClkEn. Then MMC Host controller starts to send command to Multimedia Cards. And StartEn bit is cleared automatically when the MMC Host controller finishes current operation. ClkEn bit makes MMC clock to be enabled. In this case, the MMC clock (MMCCLK) is generated during the operation. If this bit is zero, clock to operate control block is not generated.

You can check the end of response or operation from MMC Status register. This register also contains lots of useful information about what MMC Host controller is doing.

If the current operation does not contain data operation, you just need to poll CmdRespEnd or DataOperEnd bit. But if not, you need to have another step prior to starting. If current command requires multiple block operation, you must inform the block length and the number of block to be transferred to MMC Host controller. These controllers (mmcBlockSizeReg, mmcBlockNumberReg) can specify up to 2048 bytes for the length of block, and 64K blocks for the number of block.

Following shows the procedure for the write and read operation.

9.2.7.1 Write Operation

MMC Host controller starts the sending of data at the end of response end. And if the controller does not receive response during a specified period, it will generate response timeout error. Anyway, after the response end, if Tx FIFO is not ready (FIFO is empty), waits until the data is ready. The data transfer can be done by the three methods (polling, interrupt, and DMA (Direct Memory Access)). Polling method checks the Tx FIFO empty bit of the status register and if it is empty, you can write less than the eight word. And again wait until Tx FIFO is empty. Repeat this procedure until the operation end bit is set. Interrupt method uses the Tx FIFO empty interrupt. For every interrupt, you can write the eight words. And exit the ISR (Interrupt Service Routine). And then wait for the next interrupt. DMA method uses not ARM720T core but the DMA controller, so you must program the DMA controller before start operation. MMC Host controller must set the DmaEn bit of MMC Mode register. DMA request signal is generated whenever the number of data in Tx FIFO is less then equal to seven.

9.2.7.2 Read Operation

Multimedia Card can send both response and data currently after receiving the command from the host controller. So, MMC Host controller waits the response and data at the same time. Therefore, you must check response and data concurrently. Or you can use the response end interrupt. But in most case, after the response end, you can start read data from the Rx FIFO. This is reason why the Rx FIFO sizes with the eight words (32*8 cycles), so to fill it, the controller needs the 256 cycles. The data transfer also can be done by the three methods like the write operation. Polling method checks the Rx FIFO ready bit of the status register. This bit is activated when Rx FIFO has more than two word data. So you just read two times when you check this bit is set. Interrupt method uses the Rx FIFO full interrupt. Because the Rx FIFO has eight word depths, whenever interrupt is called, ISR reads the eight words form the Rx FIFO. In the case of the Rx FIFO full, you don't worry about it because the MMC Host controller stops the output clock not to loss on the bus. In DMA mode, the DMA request is generated when the Rx FIFO has one more words.

* Note: Errata sheet (version 1.0) includes contents of the lower subject
[Subject] A way for using both MMC and SPI mode on a system board

9.3 SMC Controller

This SmartMedia™ Card Controller is an Advanced Microcontroller Bus Architecture (AMBA) compliant System-on-a-Chip peripheral providing an interface to industry-standard SmartMedia™ Flash Memory Card. A channel has 8 control signal outputs and 8 bits of bi-directional data ports.

FEATURES

- One 3.3V SmartMedia support
- 4MB to 128MB media (both Flash and Mask ROM type)
- Interrupt mode support when erase/write operation is finished
- Unique ID SmartMedia support
- Multi-page DMA access
- Marginal timing operation settable.

9.3.1 External Signals

Pin Name	Type	Description
SMD [7:0]	I/O	Smart Media Card (SSFDC) 8bit data signals
nSMWP	O	Smart Media Card (SSFDC) write protect
nSMWE	O	Smart Media Card (SSFDC) write enable
SMALE	O	Smart Media Card (SSFDC) address latch enable
SMCLE	O	Smart Media Card (SSFDC) command latch enable
nSMCD	I	Smart Media Card (SSFDC) card detection signal
nSMCE	O	Smart Media Card (SSFDC) chip enable
nSMRE	O	Smart Media Card (SSFDC) read enable
nSMRB	I	Smart Media Card (SSFDC) READY/nBUSY signal. This is open-drain output so it requires a pull-up resistor.

9.3.2 Registers

Address	Name	Width	Default	Description
0x8001.6000	SMCCMD	32	0x0	SmartMedia Card Command register
0x8001.6004	SMCADR	27	0x0	SmartMedia Card Address register
0x8001.6008	SMCDATW	32	0x0	Data written to SmartMedia Card
0x8001.600C	SMCDATR	32	0x0	Data received from SmartMedia Card
0x8001.6010	SMCCONF	8	0x0	SmartMedia Card controller configuration register
0x8001.6014	SMCTIME	20	0x0	Timing parameter register
0x8001.601C	SMCSTAT	32	0x0	SmartMedia Card controller status register

Table 9-16 SmartMedia Controller Register Summary

9.3.2.1 SMC Command Register (SMCCMD)

0x8001.6000															
31	30	29	28	27	26	25	24	23	22	21	20	19	18	17	16
Hidden Command 0								Hidden Command 1							
15	14	13	12	11	10	9	8	7	6	5	4	3	2	1	0
Main Command								Second Command							
Bits	Type	Function													
31:24	R/W	Hidden Command 0. This Unique ID feature will be available to 128Mb NAND Flash and upward density products to prevent illegal copy of music files. Unique ID is put into redundant block of SmartMedia. Use this hidden command to access redundant block that cannot be accessed with open command, This byte filed is ignored when user block is accessed. For more information, refer to SmartMedia Maker's datasheet.													
23:16	R/W	Hidden Command 1. Read ID command returns whether the SmartMedia card supports unique ID or not. Hidden 2 step command for Samsung is 30h-65h and for Toshiba is 5Ah-													

B5h. To return back to user block after accessing redundant block area, Reset command (FFh) should be carried out.

15:8 R/W There are 9 commands to operate SmartMedia card. This controller supports only parts of them (bold type). Set 1ST command into this byte field except writing to SmartMedia. For write operation, set this byte field to Serial Data Input (80h) and set Second Command byte field to Page Program (10h).

Function	1 ST cycle	2 ND cycle	Function	1 ST cycle	2 ND cycle
Serial Data Input	80h		Page Program		10h
Read 0	00h		Block Erase	60h	D0h
Read 1	01h		Status Read	70h	
Read 2	50h		ID Read	90h	
Reset	FFh				

7:0 R/W Set 2ND command here

9.3.2.2 SMC Address Register (SMCADR)

0x8001.6004

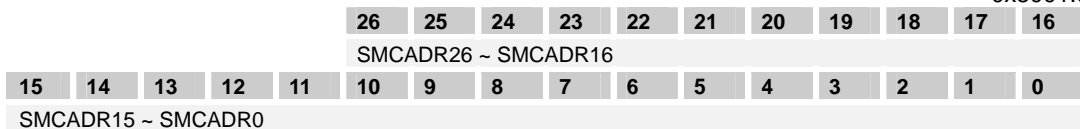

Bits	Type	Function														
26:0	R/W	<p>SMC Address. SMC controller begins to operate after writing an address to SMCADR. Hence a valid command must be set to SMCCMD before writing to SMCADR. However, reset and status read commands activate SMC controller after writing to SMCCMD because they do not require an address.</p> <p>Following table shows valid address range according to SmartMedia card size.</p> <table border="1"> <thead> <tr> <th>Model</th> <th>Valid Page Address</th> </tr> </thead> <tbody> <tr> <td>4 MB</td> <td>SMCADR0 ~ SMCADR21</td> </tr> <tr> <td>8 MB</td> <td>SMCADR0 ~ SMCADR22</td> </tr> <tr> <td>16 MB</td> <td>SMCADR0 ~ SMCADR23</td> </tr> <tr> <td>32 MB</td> <td>SMCADR0 ~ SMCADR24</td> </tr> <tr> <td>64 MB</td> <td>SMCADR0 ~ SMCADR25</td> </tr> <tr> <td>128 MB</td> <td>SMCADR0 ~ SMCADR26</td> </tr> </tbody> </table>	Model	Valid Page Address	4 MB	SMCADR0 ~ SMCADR21	8 MB	SMCADR0 ~ SMCADR22	16 MB	SMCADR0 ~ SMCADR23	32 MB	SMCADR0 ~ SMCADR24	64 MB	SMCADR0 ~ SMCADR25	128 MB	SMCADR0 ~ SMCADR26
Model	Valid Page Address															
4 MB	SMCADR0 ~ SMCADR21															
8 MB	SMCADR0 ~ SMCADR22															
16 MB	SMCADR0 ~ SMCADR23															
32 MB	SMCADR0 ~ SMCADR24															
64 MB	SMCADR0 ~ SMCADR25															
128 MB	SMCADR0 ~ SMCADR26															

9.3.2.3 SMC Data Write Register (SMCDATW)

0x8001.6008

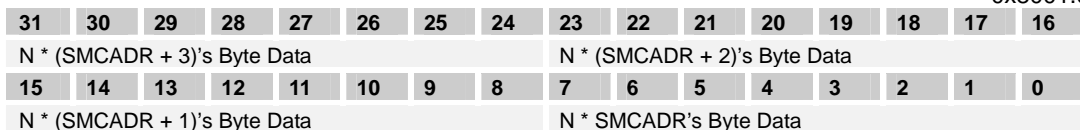

Bits	Type	Function
31:0	R/W	<p>Four byte data written to this register will be sent to SmartMedia. SMC controller receives a 32bit data from host controller or DMA controller. Then It starts to transmit from least significant byte to most significant byte, one byte at a time. This SMC controller writes a whole page at a single write transaction, so it requires 132 times consecutive writing (528 = 512+16 bytes). A page program process is as follows:</p> <ol style="list-style-type: none"> Set SMCCMD to xxxx8010h (Sequential Data Input + Page Program), SMCADR to desired target page address space, and then write first 4 byte data onto SMCDATW. If DMA mode enabled, DMA interrupt will be repeated until it writes 528 byte data to SmartMedia. In normal mode, interrupt will be generated every 4 bytes write. At the end of sequential data input, SmartMedia goes into page program mode by transmitting the second command to SmartMedia. Usually page program takes long time, no polling status register is recommended. SMC controller automatically generates write finish

interrupt when SmartMedia comes back to ready mode.

9.3.2.4 SMC Data Read Register (SMCDATR)

0x8001.600C

31	30	29	28	27	26	25	24	23	22	21	20	19	18	17	16
N * (SMCADR + 3)'s Byte Data								N * (SMCADR + 2)'s Byte Data							
15	14	13	12	11	10	9	8	7	6	5	4	3	2	1	0
N * (SMCADR + 1)'s Byte Data								N * SMCADR's Byte Data							

Bits	Type	Function
31:0	R	<p>Four byte data read from SmartMedia is stored in this register. SMC controller receives a byte data from SmartMedia and stores it into 4 byte internal buffer to create 32bit data. First read byte data is stored at least significant byte and fourth byte data is stored at most significant byte of buffer. Host controller or DMA controller read this register to get 4 byte data at a time. This SMC controller reads a whole page at a single read transaction, so it requires 132 times consecutive reading. A page reading process is as follows:</p> <ol style="list-style-type: none"> 1. Set SMCCMD to xxxx00yyh (xxxx can be unique ID if redundant area accessed, yy is don't care. Only 00h command is valid. No 01h or 50h command supported) and then set SMCADR to target page address. 2. SMC controller will access SmartMedia with given command and address. 3. Interrupt (or DMA interrupt according to interrupt mode setting) will be generated after first four byte read. Like writing process, reading process reads a whole 528 byte in a page at a single transaction, so interrupt will be 132 times. <p>Against to write operation, there is no read finish interrupt because we can count the number of read transfers in software or can get the total access word size from BYTE COUNT of SMCSTAT.</p>

9.3.2.5 SMC Configuration Register (SMCCONF)

0x8001.6010

31	6	5	4	3	2	1	0
POWER ENABLE	SAFE MARGIN	SMC ENABLE	CONT PAGE EN	INTR EN	DMA EN	UNIQUE ID EN	BIG CARD ENABLE

Bits	Type	Function
31	R/W	Power on bit. To activate SMC controller, set this bit. Reset will fall the controller into the deep sleep mode.
30:7	-	Reserved. Keep these bits to zero.
6	R/W	Safe margin enable bit. In normal mode, chip select signal changes simultaneously with read enable and write enable signals. But when this bit set, the duration of read and write enable signal applied to SmartMedia is reduced by 1 automatically. By enabling this, the rising edge of read and write enable signal will be earlier than the rising edge of chip enable, which guarantees latching data safely.
5	R/W	SMC controller enable bit. Reset this bit will make SMC controller stay in standby mode. No interrupt generated, no action occurred.
4	R/W	Continuous page read enable. If this bit set, then multi-page can be accessed in a single command and address setting. Usually DMA controller accesses multiple pages with a start address and a predefined size. Setting DMA access size in SMCTIME and enabling this bit will automatically read or write SmartMedia with DMA mode.
3	R/W	Interrupt enable. After reading a word or before writing a word, the interrupt bit of SMCSTAT will be set and interrupt will occur if INTR EN is enabled. If this bit is disabled, software must poll the interrupt flag of SMCSTAT to know the occurrence of an interrupt. After writing a whole page (or pages when CONT PAGE EN is enabled) to SmartMedia, write finish interrupt will also be generated to notice that the SmartMedia complete the write operation successfully.
2	R/W	DMA enable. If set, all interrupt during read or write data will be sent to DMA controller. However, write finish interrupt is a still normal interrupt. To minimize CPU burden and to maximize BUS utilization, enabling both interrupt and DMA mode together is recommended.
1	R/W	Redundant page enable. When use SmartMedia with unique ID and want to access redundant page area, set high. This bit cannot be cleared automatically, so in order to read

		open page area clear this bit and set a reset command to SMCCMD.
0	R/W	Larger than 32MB SmartMedia support enable. When using 64MB or 128MB SmartMedia, set this bit high.

9.3.2.6 SMC Timing Parameter Register (SMCTIME)

0x8001.6014

31	30	29	28	27	26	25	24		22	21	20	19	18	17	16
DMA SIZE				WAIT COUNTER				BYTE COUNTER							
						9	8						2	1	0
HIGH COUNTER								LOW COUNTER							

Bits	Type	Function
31:28	R/W	Multi-page DMA size bit. Maximum 15 pages are accessible at a time. 0000 = not defined. 0001 = 1 page 0010 = 2 pages ... 1111 = 15 pages
27:24	R/W	Wait counter maximum limit value. Waiting time delay between address latch and write data in page program mode or between address latch and read data in read ID mode and read status register is determined by this register. 0000 = 1 BCLK width 0001 = 2 BCLK width ... 1111 = 16 BCLK width
23	-	Reserved
22:16	R/W	Should set these bits as 0x7F to access full 512 bytes page at one access command (read or program).
15:10	-	Reserved
9:8	R/W	High pulse width value of read enable and write enable signal. The width must satisfy the AC characteristics of SmartMedia to guarantee correct transfer of data. With Safety Margin enable, width will be decreased by one. 00 = 1 BCLK width (0 BCLK with safety margin enable. Don't make this case) 01 = 2 BCLK width (1 BCLK with safety margin enable) 10 = 3 BCLK width (2 BCLK with safety margin enable) 11 = 4 BCLK width (3 BCLK with safety margin enable)
7:3	-	Reserved
2:0	R/W	Low pulse width value of read enable and write enable signal. The width must satisfy the AC characteristics of SmartMedia to guarantee correct transfer of data. With Safety Margin enable, width will be decreased by one. 000 = 1 BCLK width (0 BCLK with safety margin enable, Don't make this case) 001 = 2 BCLK width (1 BCLK with safety margin enable) ... 111 = 8 BCLK width (7 BCLK with safety margin enable)

9.3.2.7 SMC Status Register (SMCSTAT)

0x8001.601C

31	30	29	28	27	26	25	24
CD INTR	nSMCE	SMCLE	SMALE	nSMWE	nSMRE	nSMWP	SMR/B
23	22	21	20	19	18	17	16
CURRENT COMMAND/CARD DETECT NOTIFICATION							
15	14	13	12	11	10	9	8
EXTRA AREA	BYTE COUNT						
7	6	5	4	3	2	1	0

INTERNAL STATE			CARD DETECT	IRQ	DRQ	BUSY
Bits	Type	Function				
31	R	Card Detect Interrupt. When card inserted or removed, card detect interrupt will be generated. In the interrupt service routine, look at this bit to identify interrupt type.				
30:24	R	Current status of output signals.				
23:16	R	Current active command. If in card detect interrupt, this byte shows 0xCD.				
15	R	Set when extra area of a page is accessed.				
14:8	R	Current address of a page in word units.				
7:4	R	Shows internal state machine's state.				
3	R	Set when SMC enable and SMC card inserted. It will be zero when card removed.				
2	R	Interrupt flag				
1	R	DMA interrupt flag				
0	R	Reset shows SMC is in idle mode. Set means SMC in working mode.				

9.4 Sound Interface

The Sound Control Unit (SCU) is an interface block to transfer sound data to external speakers. The SCU is an interface block used to send data to the external speaker through the internal 8-bit DA converter. It can process 44.1/22.05/11.025/8KHz sampled 8-bit mono or 16-bit stereo sound data. This unit has a 32-bit register to receive sound data from the CPU through DMA or interrupt mode. This unit requests the DMA or interrupt controller every 32-bit processing time, which depends on the sampling frequency. It has two separate signals for DAC that indicate the direction of data for the stereo sound. Either higher or lower byte of 16-bit stereo sound data can be played through the left or right speaker by programming the control register. During mono playback, this unit sends the same data for the left and right channels.

There are two test registers. Both these registers should be cleared during normal operation. TICCLK port is also assigned for production test only.

Features

- Sound playback
- Supports programmable sampling rate
- 32-bit internal data register for DMA
- Auto DMA request
- 8-bit resolution DAC control
- Supports non-overlapping left/right signal for DAC
- Supports test mode

9.4.1 External Signals

Pin Name	Type	Description
ADACR	O	Sound DAC output for Right
ADACL	O	Sound DAC output for Left

9.4.2 Registers

Address	Name	Width	Default	Description
0x8001.3000	SCONT	8	0x0	Control register
0x8001.3004	SDADR	32	0x0	Data register

Table 9-17 Sound Controller Register Summary

9.4.2.1 SCONT

		0x8001.3000							
		7	6	5	4	3	2	1	0
Reserved		MONO	DMA	POR	DAC	RL	SAMP		INT
Bits	Type	Function							
7	R/W	0 – stereo 1 – mono							
6*	R/W	DMA request masking bit 0 - masking 1 – unmasking							
5	R/W	This bit should be cleared to minimize power consumption when not in use. 0 - power down mode 1 - normal mode							
4	R/W	DAC operation enable/disable. During disabled, DAC is in power save mode. 0 - DAC disable 1 - DAC enable							
3	R/W	When cleared, lower byte data goes to left speaker. (ADACL pin) 0 - lower byte data goes to ADACL pin 1 - lower byte data goes to ADACR pin							
2:1	R/W	Programmable sampling rate							

		00 - 11.025KHz
		01 - 22.05KHz
		10 - 44.1KHz
		11 - 8KHz
0*	R/W	0 Interrupt request masking bit
		0 - masking
		1 - unmasking

Note Those bits marked with an asterisk should not be enabled simultaneously during normal operation. (The programmer can select only one--either Interrupt or DMA mode.)

9.4.2.2 SDADR

This register can be programmed after setting Bit 5 of the SCONT register.

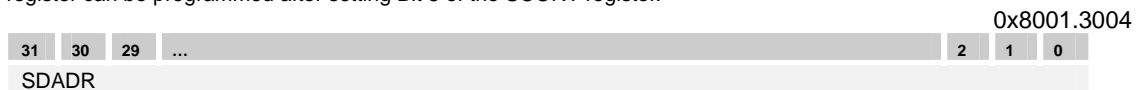

Bits	Type	Function
32	R/W	Sound Data This register receives data by DMA Controller or CPU. This unit processes the lower 16-bit data followed by the higher 16-bit data. After the lower 16-bit is processed, this unit is ready to receive new data and sends a request signal to DMA Controller or CPU. In mono mode, the lower byte is processed first followed by the higher byte.

9.5 USB Slave Interface

This section describes the implementation-specific options of USB protocol for a device controller. It is assumed that the user has knowledge of the USB standard. This USB Device Controller (USBDC) is chapter 9 (of USB specification) compliant, and supports standard device requests issued by the host. The user should refer to the Universal Serial Bus Specification revision 1.1 for a full understanding of the USB protocol and its operation. (The USB specification 1.1 can be accessed via the World Wide Web at: <http://www.usb.org>). The USBDC is a universal serial bus device controller (slave, not hub or host controller) which supports three endpoints and can operate half-duplex at a baud rate of 12 Mbps. Endpoint 0, by default is only used to communicate control transactions to configure the USBDC after it is reset or physically connected to an active USB host or hub. Endpoint 0's responsibilities include connection, address assignment, endpoint configuration and bus numeration.

The connected host that can get a device descriptor stored in USBDC's internal ROM via endpoint 0 configures the USBDC. The USBDC uses two separate 32 x 8 bit FIFO to buffer receiving and transmitting data to/from the host. The external pins dedicated to this interface are UVPO, UVP, UVMO, UVM, URCVIN, nUSBOE and USUSPEND. These signals should be connected to USB transceiver such as PDIUSBP11 provided by Philip Semiconductor. Refer to data sheet PDIUSBP11). The CPU can access the USBDC using Interrupt controller, by setting the control register appropriately. This section also defines the interface of USBDC and CPU.

* Notice: Don't use this USB device function with a LS device (like a USB mouse) in a same HUB.

FEATURES

- Full universal serial bus specification 1.1 compliant.
- Receiver and Transceiver have 32 bytes FIFO individually (this supports maximum data packet size of bulk transfer).
- Internal automatic FIFO control logic. (According to FIFO status, the USBDC generates Interrupt service request signals to the CPU)
- Supports high-speed USB transfer (12Mbps).
- There are two endpoint of transmitter and receiver respectively, totally three endpoints including endpoint 0 that has responsibility of the device configuration.
- CPU can access the internal USB configuration ROM storing the device descriptor for Hand-held PC (HPC) by setting the predefined control register bit.
- USB protocol and device enumeration is performed by internal state-machine in the USBDC.
- The USBDC only supports bulk transfer of 4-transfer type supported by USB for data transfer.
- Endpoint FIFO (Tx, Rx) has the control logic preventing FIFO overrun and under run error.

Note Product ID: 7210 Vendor ID: 05b4 * can be modified

Reference document - *Hms30c7210_UsbDownLoad_V1.3.2Guide_with_Errata.pdf*

[Location: <http://www.MagnaChip.com> -SP-MCU-ARM Core Based-HMS30C7210 Reference Design Kit-Miscellany]

9.5.1 Block Diagram

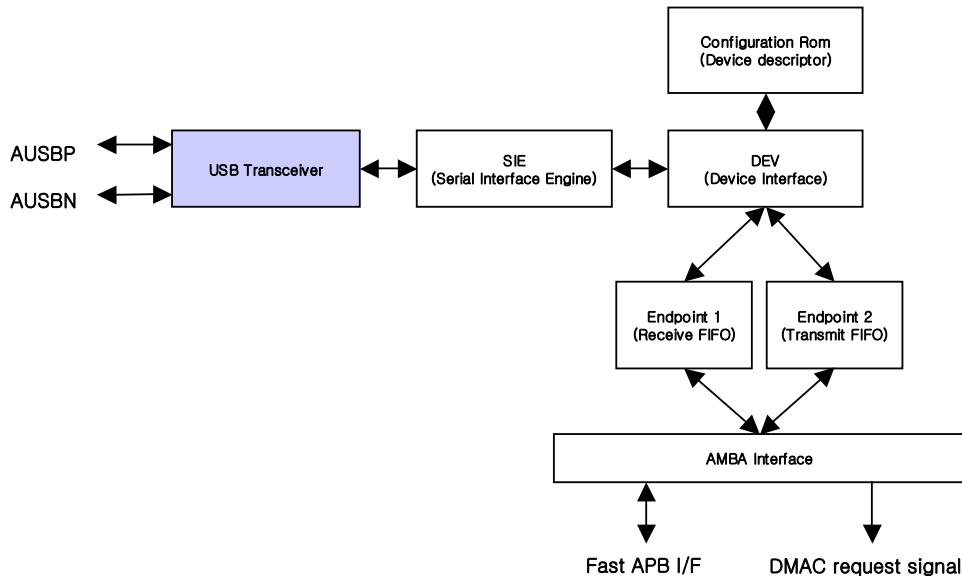

Figure 9-1 USB Block Diagram

The USB, Figure 9-2: USB Block Diagram comprises the Serial Interface Engine (SIE) and Device Interface (DEV). The SIE connects to the USB through a bus transceiver, and performs NRZI conversion, bit un-stuffing, CRC checking, packet decoding and serial to parallel conversion of the incoming data stream. In outgoing data, it does the reverse, that is, parallel to serial of outgoing data stream and packetizing the data, CRC generation, bit stuffing and NRZI generation.

The DEV provides the interface between the SIE and the device's endpoint FIFO, ROM storing the device descriptor. The DEV handles the USB protocol, interpreting the incoming tokens and packets and collecting and sending the outgoing data packets and handshakes. The endpoints FIFO (RX, TX) give the information of their status (full/ empty) to the AMBA interface and AMBA I/F enable the CPU to access the FIFO's status register and the device descriptor stored in ROM. The AMBA interface generates a FIFO read/write strobe without FIFO's errors, based on APB signal timing. In case of data transmitting through TX FIFO (when USB generates an OUT token, AMBA I/F generates Interrupt to CPU), the user should set the transmitting enable bit in the control register. If the error of FIFO (Rx: overrun, TX: under-run) occurs, the AMBA I/F cannot generate FIFO read/ write.

9.5.2 Theory of Operation

The MagnaChip USB Core enables a designer to connect virtually any device requiring incoming or outgoing PC data to the Universal Serial Bus. As illustrated in Figure 9-2: USB Block Diagram, the USB core comprises two parts, the SIE and DEV. The SIE connects to the Universal Serial Bus via a bus transceiver. The interface between the SIE and the DEV is a byte-oriented interface that exchanges various types of data packets between two blocks.

Serial Interface Engine

The SIE converts the bit-serial, NRZI encoded and bit-stuffed data stream of the USB into a byte and packet oriented data stream required by the DEV. As shown in Figure 9-3: MagnaChip Serial Interface Engine, it comprises seven blocks: Digital Phase Lock Loop, Input NRZI decode and bit-unstuff, Packet Decoder, Packet Encoder, Output bit stuff and NRZI encode, Counters, and the CRC Generation & Checking block. Each of the blocks is described in the following sections.

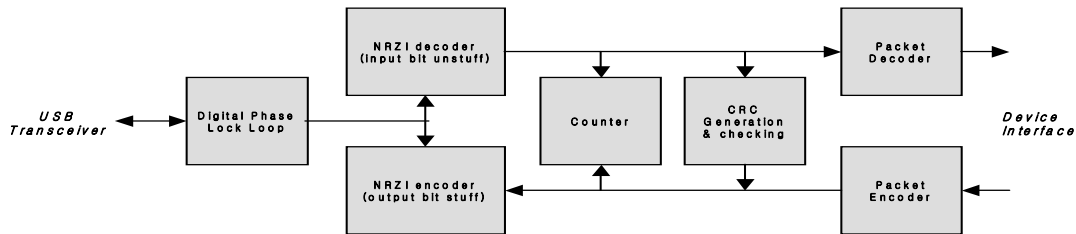

Figure 9-2 USB Serial Interface Engine

Digital Phase Lock Loop

The Digital Phase Lock Loop module takes the incoming data signals from the USB, synchronizes them to the 48MHz input clock, and then looks for USB data transitions. Based on these transitions, the module creates a divide-by-4 clock called the usbclock. Data is then output from this module synchronous to the usbclock.

Input NRZI decode and bit-unstuff

The Input NRZI decodes and bit-unstuff module extracts the NRZI encoded data from the incoming USB data. Transitions on the input serial stream indicate a 0, while no transition indicates a 1. Six ones in a row cause the transmitter to insert a 0 to force a transition, therefore any detected zero bit that occurs after six ones is thrown out.

Packet Decoder

The Packet Decoder module receives incoming data bits and decodes them to detect packet information. It checks that the PID (Packet ID) is valid and was sent without error.

After decoding the PID, the remainder of the packet is split into the address, endpoint, and CRC5 fields, if present. The CRC Checker is notified to verify the data using the incoming CRC5 field. If the packet is a data packet, the data is collected into bytes and passed on with an associated valid bit. Table 9-6: Supported PID Types shows the PID Types that are decoded (marked as either Receive or Both). At the end of the packet, either the packetok or packetnotok signal is asserted. Packetnotok is asserted if any error condition arose (bad valid bit, bit-stuff, bad PID, wrong length of a field, CRC error, etc.).

PID Type	Value	Send/Receive	PID Type	Value	Send/Receive
OUT	4'b0001	Receive	DATA1	4'b1011	Both
IN	4'b1001	Receive	ACK	4'b0010	Both
SOF	4'b1101	Receive	NAK	4'b1010	Send
SETUP	4'b0000	Receive	STALL	4'b1110	Send
DATA0	4'b0011	Both	PRE	4'b1100	Receive

Table 9-18 USB Supported PID Types

Packet Encoder

The Packet Encoder creates outgoing packets based on signals from the DEV. Table 9-6: Supported PID Types shows the PID Types that can be encoded (marked as Send or Both). For each packet type, if the associated signal sends type is received from the DEV, the packet is created and sent. Upon completion of the packet, packettypesent is asserted to inform the DEV of the successful transmission. The Packet Encoder creates the outgoing PID, grabs the data from the DEV a byte at a time, signals the CRC Generator to create the CRC16 across the data field, and then sends the CRC16 data. The serial bits are sent to the Output bit stuff and NRZI encoder.

Output bit stuff and NRZI encoder

The Output bit stuff and NRZI encoder takes the outgoing serial stream from the Packet Encoder, inserts stuff bits (a zero is inserted after six consecutive ones), and then encodes the data using the NRZI encoding scheme (zeroes cause a transition, ones leave the output unchanged).

Counter block

The Counter block tracks the incoming data stream in order to detect the following conditions: reset, suspend, and turnaround. It also signals to the transmit logic (Output NRZI and bit stuff) when the bus is idle so transmission can begin.

Generation and Checking block

The Generation and Checking block checks incoming CRC5 and CRC16 data fields, and generates CRC16 across outgoing data fields. It uses the CRC polynomial and remainder specified in the USB Specification Version 1.1.

Device Interface

The DEV shown in Figure 9-4: Device Interface works at the packet and byte level to connect a number of endpoints to the SIE. It understands the USB protocol for incoming and outgoing packets, so it knows when to grab data and how to correctly respond to incoming packets. A large portion of the DEV is devoted to the setup, configuration, and control features of the USB. As shown in Figure 9-4: Device Interface the DEV is divided into three blocks: Device Controller, Device ROM, and Start of Frame. The three blocks are described in the following sections.

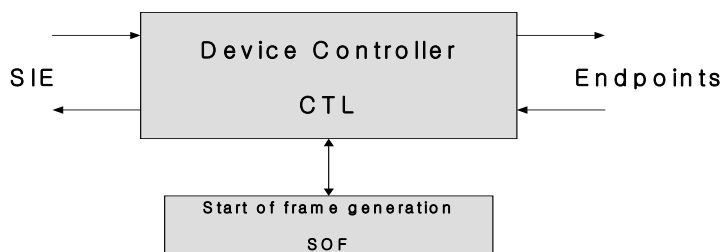

Figure 9-3 USB Device Interface Device Controller

Device Controller

The Device Controller contains a state machine that understands the USB protocol. The (SIE) provides the Device Controller with the type of packet, address value, endpoint value, and data stream for each incoming packet. The Device Controller then checks to see if the packet is targeted to the device by comparing the address/endpoint values with internal registers that were loaded with address and endpoint values during the USB enumeration process. Assuming the address/endpoint is a match, the Device Controller then interprets the packet. Data is passed on to the endpoint for all packets except SETUP packets, which are handled specially. Data toggle bits (DATA0 and DATA1 as defined by the USB spec) are maintained by the Device Controller. For IN data packets (device to host) the Device Controller sends either the maximum number of bytes in a packet or the number of bytes available from the endpoint. All packets are acknowledged as per the spec. For SETUP packets, the incoming data is extracted into the relevant internal fields, and then the appropriate action is carried out. Table 9-7: Supported Setup Requests lists the types of setup operations that are supported.

Setup Request	Value	Supported	Setup Request	Value	Supported
Get Status	0	Device, Interface, Endpoint	Get Configuration	8	Device
Clear Feature	1	Endpoints Only	Set Configuration	9	Device
Set Feature	3	Not supported	Get Interface	10	Not supported
Set Address	5	Device	Set Interface	11	Not supported
Get Descriptor	6	Device	Synch Frame	12	Not supported
Set Descriptor	7	Not supported			

Table 9-19 USB Supported Setup Requests

Start of Frame

The Start of Frame logic generates a pulse whenever either the incoming Start of Frame (SOF) packet arrives or approximately 1 ms after it the last one arrived. This allows an isochronous endpoint to stay in sync even if the SOF packet has been garbled.

9.5.3 Endpoint FIFOs (Rx, Tx)

Each endpoint FIFO has the specific number of FIFO depth according to data transfer rate. In case of maximum packet size for bulk transfer is 32 bytes that is supported in USB. Each FIFO generates data ready signals (means FIFO not full or FIFO not empty) to AMBA IF. It contains the control logic for transferring 4 bytes at a read/write strobe generated by AMBA to obtain better efficiency of AMBA bus.

9.5.4 External Signals

Pin Name	Type	Description
USBP	I/O	USB transceiver signal for P+
USBN	I/O	USB transceiver signal for N+

9.5.5 Registers

Address	Name	Width	Default	Description
0x8005.1000	GCTRL	4	0x0	USB Global Configuration Register
0x8005.1004	EPCTRL	21	0x0	Endpoint Control Register
0x8005.1008	INTMASK	10	0x3ff	Interrupt Mask Register
0x8005.100C	INTSTAT	20	0x0	Interrupt Status Register
0x8005.1010	PWR	4	0x0	Power Control Register
0x8005.1018	DEVID	32	0x721005b4	Device ID Register
0x8005.101C	DEVCLASS	32	0xfffff	Device Class Register
0x8005.1020	INTCLASS	32	0xfffff	Interface Class Register
0x8005.1024	SETUP0	32	-	SETUP Device Request Lower Address
0x8005.1028	SETUP1	32	-	SETUP Device Request Upper Address
0x8005.102C	ENDP0RD	32	-	ENDPOINT0 Read Address
0x8005.1030	ENDP0WT	32	-	ENDPOINT0 WRITE Address
0x8005.1034	ENDP1RD	32	-	ENDPOINT1 READ Address
0x8005.1038	ENDP2WT	32	-	ENDPOINT2 WRITE Address

Table 9-20 USB Slave interface Register Summary

9.5.5.1 GCTRL

					0x8005.1000		
31	4			3	2	1	0
Reserved				TRANSel	WBack	Resume	DMADis
Bits	Type	Function					
3	R/W	USB Transceiver power-down mode selection. When this bit is high, SUSPEND signal of internal USB transceiver is forced to go high immediately. This is for power-down scheme of that transceiver when USB function is NOT used. It is recommended that this value keeps zero while USB normal operation					
2	R/W	HMS30C7210 does not supports Write-Back clear mode for Interrupt Status Register. This bit must be set to '0'.					
1	R/W	This Enables Remote Resume Capabilities. When This Bit Set, USB Drives remote resume signaling. Should be cleared to stop resume					
0	R	DMA Disable bit. HMS30C7210 does not support DMA, so value of this bit (logic 1) is not changeable					

9.5.5.2 EPCTRL

											0x8005.1004	
31	21		20	19	18	17	16	15	14	13	12	
Reserved			CLR2	CLR1	CLR0	E2TXB	E2SND	E2NK	E2ST	E2En		
11	10	9	8	7	4	3	2	1	0			

E1RCV E1NK E1ST E1En E0TXB E0NK E0ST E0TR E0En

Bits	Type	Function
20	R/W	Clear Endpoint2 FIFO Pointer(Auto cleared by Hardware).
19	R/W	Clear Endpoint1 FIFO Pointer(Auto cleared by Hardware).
18	R/W	Clear Endpoint0 FIFO Pointer(Auto cleared by Hardware).
17~16	R/W	USB Can Transmit NON Maximum sized Packet. This Field contains the residue byte which should be transmitted.
15	R/W	This Bit enables NON Maximum sized Packet transfer. After NON maximum sized packet transfer, this bit is auto cleared and return to Maximum Packet size transfer mode.
14	R/W	When This Bit is Set, and Endpoint2 is not enabled, USB should send NAK Handshake
13	R/W	When This Bit is Set, and Endpoint2 is not enabled, USB should send STALL Handshake
12	R/W	Enable Endpoint2 as IN Endpoint
11	R/W	This bit must be zero. So only maximum packet size RX transfer mode is supported. This means RX (HOST OUT) data packet size is fixed to 32 bytes only.
10	R/W	When This Bit is Set, and Endpoint1 is not enabled, USB should send NAK Handshake
9	R/W	When This Bit is Set, and Endpoint1 is not enabled, USB should send STALL Handshake
8	R/W	Enable Endpoint1 as OUT Endpoint
7~4	R/W	This Bit Stores the Byte Count which should be transmitted to HOST when IN token is received (Exception :: When This bit is 0, 8 Byte are transferred)
3	R/W	When This Bit is Set, and Endpoint0 is not enabled, USB should send NAK Handshake
2	R/W	When This Bit is Set, and Endpoint0 is not enabled, USB should send STALL Handshake
1	R/W	When this Bit1, Endpoint0 is configured to IN endpoint. (others OUT endpoint)
0	R/W	Enable Endpoint0

9.5.5.3 INTMASK

0x8005.1008

31	10	9	8	7	6	5	4	3	2	1	0
Reserved	E0STL	SUS	RESET	E2EM	E1OV	E1FU	E0EM	E0OV	E0FU	SET	

Bits	Type	Function
9	R/W	Mask Endpoint0 Stall Interrupt
8	R/W	Mask SUSPEND Interrupt
7	R/W	Mask USB Cable RESET Interrupt
6	R/W	Mask Endpoint2 Empty Interrupt
5	R/W	Mask Endpoint1 Overrun Interrupt (May not be used)
4	R/W	Mask Endpoint1 Full Interrupt
3	R/W	Mask Endpoint0 Empty Interrupt
2	R/W	Mask Endpoint0 Overrun Interrupt (May not be used)
1	R/W	Mask Endpoint0 Full Interrupt
0	R/W	Mask Endpoint0 Setup Token Received Interrupt

9.5.5.4 INTSTAT

0x8005.100C

31	20	19	14	13	0				
Reserved		EP1RXBYTE		EP0RXBYTE					
9	8	7	6	5	4	3	2	1	0
E0STL	SUS	RESET	E2EM	E1OV	E1FU	E0EM	E0OV	E0FU	SET

Bits	Type	Function
19~14	R/W	Currently Remained Byte In Endpoint1 Receive FIFO which should be read by HOST
13~10	R/W	Currently Remained Byte in Endpoint0 Receive FIFO which should be read by HOST
9	R/W	Endpoint0 Stall Interrupt
8	R/W	SUSPEND Interrupt
7	R/W	USB Cable RESET Interrupt
6	R/W	Endpoint2 Empty Interrupt

5	R/W	Endpoint1 Overrun Interrupt (May not be used)
4	R/W	Endpoint1 Full Interrupt
3	R/W	Endpoint0 Empty Interrupt
2	R/W	Endpoint0 Overrun Interrupt (May not be used)
1	R/W	Endpoint0 Full Interrupt
0	R/W	Endpoint0 Setup Token Received Interrupt

9.5.5.5 PWR

				0x8005.1010	
31	4	3	2	1	0
Reserved			EnBCLK	SWUPDATE	PwrMD
Bits	Type	Function			
3	R/W	Enable BCLK to USB FIFO Block. .			
2	R/W	USB Core Power Mode Update Mode, When This Bit 1, Only software can update USB Core Power Mode. But this bit 0, USB core automatically update its power status according to cable state			
1	~ R/W	USB Power Mode			
0		00 : Full Power Down -> Usb core can't detect any cable activity 01 : Power Power Down -> Usb can detect any cable activity but core doesn't operate normally 10 : Full Power Operation Mode			

9.5.5.6 DEVID

				0x8005.1018	
Bits	Type	Function			
31:0	R/W	USB Core Can Change Device ID Field by writing Appropriate Device ID Value to This Register			

9.5.5.7 DEVCLASS

				0x8005.101C	
Bits	Type	Function			
23:0	R/W	USB Core Can Change Device Class Field by writing Appropriate Device ID Value to This Register			

9.5.5.8 INTCLASS

				0x8005.1020	
Bits	Type	Function			
23:0	R/W	USB Core Can Change Interface Class Field by writing Appropriate Device ID Value to This Register			

- While USB device configuration process, HOST requests Descriptors.
This USB block has a hard-wired descriptor ROM, but there are 3 fields (whole 10 bytes size) user adjustable.

[DEVICE DESCRIPTOR]

- see USB spec. 1.1 (9.6 Standard USB Descriptor Definitions) for more detail

OFFSET (BYTE)	INITIAL VALUE	DESCRIPTION	ADJUSTABLE
h00	h12	length	
h01	h01	DEVICE	
h02	h00	spec version 1.00	
h03	h01	spec version	
h04	hFF	device class	YES
h05	hFF	device sub-class	YES
h06	hFF	vendor specific protocol	YES
h07	h08	max packet size	

h08	hB4	vendor id	YES
h09	h05	vendor id (05b4) for HME	YES
h0a	h02	product id	YES
h0b	h72	product id (7210) for HME7210	YES
h0c	h01	device release #	
h0d	h00	device release #	
h0e	h00	manufacturer index string	
h0f	h00	product index string	
h10	h00	serial number index string	
h11	h01	number of configurations	

* DEVID register has 32-bit width and it covers vendor id to product id (offset from h08 to h0b): DEVID [31:24] – h0b, DEVID [23:16] – h0a, DEVID [15:8] – h09, DEVID [7:0] – h08

* DEVCLASS register has 24-bit width and it covers device class to vendor specific protocol (offset from h04 to h06): DEVCLASS [23:16] – h06, DEVCLASS [15:8] – h05, DEVCLASS [7:0] – h04

[CONFIGURATION DESCRIPTOR]

OFFSET (BYTE)	INITIAL VALUE	DESCRIPTION	ADJUSTABLE
h00	h09	Length of this descriptor	
h01	h02	CONFIGURATION (2)	
h02	h20	Total length includes endpoint descriptors	
h03	h00	Total length high byte	
h04	h01	Number of interfaces	
h05	h01	Configuration value for this one	
h06	h00	Configuration - string	
h07	h80	Attributes - bus powered, no wakeup	
h08	h32	Max power - 100 ma is 50 (32 hex)	
h09	h09	Length of the interface descriptor	
h0a	h04	INTERFACE (4)	
h0b	h00	Zero based index of this interface	
h0c	h00	Alternate setting value (?)	
h0d	h02	Number of endpoints (not counting 0)	
h0e	hFF	Interface class, ff is vendor specific	YES
h0f	hFF	Interface sub-class	YES
h10	hFF	Interface protocol	YES
h11	h00	Index to string descriptor for this interface	
h12	h07	Length of this endpoint descriptor	
h13	h05	ENDPOINT (5)	
h14	h01	Endpoint direction (00 is out) and address	
h15	h02	Transfer type – h02 = BULK	
h16	h20	Max packet size - low : 32 byte	
h17	h00	Max packet size - high	
h18	h00	Polling interval in milliseconds (1 for iso)	
h19	h07	Length of this endpoint descriptor	
h1a	h05	ENDPOINT (5)	
h1b	h82	Endpoint direction (80 is in) and address	
h1c	h02	Transfer type – h02 = BULK	
h1d	h20	Max packet size - low : 32 byte	
h1e	h00	Max packet size - high	
h1f	h00	Polling interval in milliseconds (1 for iso)	

* see USB spec. 1.1 (9.6 Standard USB Descriptor Definitions) for more detail

* The descriptor has 4 parts : Configuration, Interface, Endpoint1, Endpoint2 (doubled lines)

[STRING DESCRIPTOR]

OFFSET	INITIAL VALUE	DESCRIPTION	ADJUSTABLE
h0	h02	size in bytes	
h1	h03	STRING type (3)	

* This index zero string descriptor means a kind of look up table. As there is no other string descriptor and as there is no further information in this descriptor, USB block does not support strings. (All string index fields are filled with zero)

9.5.5.9 SETUP0 / SETUP1

0x8005.1024 / 0x8005.1028

Bits	Type	Function
31:0	R/W	USB Core can accept vendor specific protocol command using Endpoint0. This Register contains previously received Setup Device Request Value (64-bit Wide, half in each Register)

- Below is Request format from HOST when configuration.

[Standard Device Request Format]

bmRequestType	bRequest	wValue	wIndex	wLength
Byte 0	Byte 1	Byte 2	Byte 3	Byte 4
		Byte 5	Byte 6	Byte 7

When HOST sends request to USB device, this USB block handles a few requests by SIE (Serial Interface Engine).

This is the condition of requests which this USB SIE can handle.

- Request Type must be Standard (b00): see USB spec. 9.3 Table 9-2 'Format of Setup Data' for more detail. Offset 0 (bmRequestType field) D[6:5] (Type) ; 00 – Standard, 01 Class, 10 – Vendor, 11 – reserved.
- Request must be one of these: GET_DESCRIPTOR, SET_ADDRESS, SET_INTERFACE, SET_CONFIGURATION, GET_INTERFACE, GET_CONFIGURATION and GET_STATUS.

So for requests other than above, HMS30C7210 USB sets 9.5.5.4 INTSTAT [0] and it means HOST sent Setup Request that USB SIE cannot handle by itself and these 9.5.5.9 SETUP0 and 9.5.5.10 SETUP1 register hold Device Request Data (8 bytes : 64 bit described above). This function is to handle standard requests that SIE cannot handle and to handle vendor specific requests.

* Note: 9.5.5.4 INTSTAT [0] bit will not go 'high' in case of Setup request if SIE can handle that request by itself.

9.5.5.10 ENDP0RD

0x8005.102C

Bits	Type	Function
31:0	R/W	Each Endpoint 0 FIFO Read

9.5.5.11 ENDP0WT

0x8005.1030

Bits	Type	Function
31:0	R/W	Each Endpoint 0 FIFO Write

9.5.5.12 ENDP1RD

0x8005.1034

Bits	Type	Function
31:0	R/W	Each Endpoint 1 FIFO Read

9.5.5.13 ENDP2WT

0x8005.1038

Bits	Type	Function
31:0	R/W	Each Endpoint 2 FIFO Write

10 SLOW AMBA PERIPHERALS

10.1 ADC Interface Controller

HMS30C7202 has internal ADC and ADC interface logic for analog applications of touch panel interface, two 8-bit battery check, and one 8-bit sound sampling. If user doesn't need these applications or want to use for other functions, there's a direct ADC control register available.

FEATURES

- 5-channel 10-bit ADC embedded
- 4-sample data per one sampling point of touch panel (use 2 channels, X and Y, 10-bit)
- Main and backup battery check function (use 2 channels, 8-bit resolution)
- Eight 32-byte sound data buffer (8-word buffer, 8-bit sound data)
- Manual and Auto ADC power down mode

10.1.1 External Signals

Pin Name	Type	Description
ADIN[0]	Analog input	Touch Panel X-axis signal input
ADIN[1]	Analog input	Touch Panel Y-axis signal input
ADIN[2]	Analog input	Main Battery value input
ADIN[3]	Analog input	Backup Battery value input
ADIN[4]	Analog input	Sound input

10.1.2 Registers

Address	Name	Width	Default	Description
0x8002.9000	ADCCR		0x80	ADC Control Register
0x8002.9004	ADCTPCR		0x0	Touch panel control register
0x8002.9008	ADCBACR		0x0	Battery check Control Register
0x8002.900C	ADCSDCR		0x0	Sound Data Control Register
0x8002.9010	ADCISR		0x0	ADC Interrupt Status Register
0x8002.901C	ADCTDCSR		0x0X	Tip Down Control/Status Register
0x8002.9020	ADCDIRCR			ADC Direct Control Register
0x8002.9024	ADCDIRDATA			ADC Direct Data read register
0x8002.9030	ADCTPXDR0			Touch Panel X Data register 0
0x8002.9034	ADCTPXDR1			Touch Panel X Data register 1
0x8002.9038	ADCTPYDR0			Touch Panel Y Data register 0
0x8002.903C	ADCTPYDR1			Touch Panel Y Data register 1
0x8002.9040	ADCTPXDR2			Touch Panel X Data register 2
0x8002.9044	ADCTPXDR3			Touch Panel X Data register 3
0x8002.9048	ADCTPYDR2			Touch Panel Y Data register 2
0x8002.904C	ADCTPYDR3			Touch Panel Y Data register 3
0x8002.9050	ADCMBDATA			Main Battery check Data Register
0x8002.9054	ADCBBDATA			Backup Battery check Data Register
0x8002.9060	ADCSDATA0			Sound Data Register
0x8002.9064	ADCSDATA1			Sound Data Register
0x8002.9068	ADCSDATA2			Sound Data Register
0x8002.906C	ADCSDATA3			Sound Data Register
0x8002.9070	ADCSDATA4			Sound Data Register
0x8002.9074	ADCSDATA5			Sound Data Register
0x8002.9078	ADCSDATA6			Sound Data Register
0x8002.907C	ADCSDATA7			Sound Data Register

Table 10-1 ADC Controller Register Summary

10.1.2.1 ADC Control Register (ADCCR)

User can set ADCPD to save power consumption by ADC. But ADC needs 10-40 ms to self calibrate for normal operation. DIRECTC bit can be used for direct accessing from CPU to ADC without interface function logic. All direct control signals are describe in ADCDIRCR register field. Basically ADC core converts Analog data to Digital data continuously in every 16 ADC operation-clocks. ADC operation clock is “aclk” (3.6864MHz) called as “PCLK” in SLOW APB

WAIT bit field select conversion time of ADC because in certain case interface logic can read wrong or unstable value from ADC. SOP bit can be used for one-shot operation to save power. When this bit is set and all ADC functions are disabled then interface logic strobe “power down” signal to ADC core. LONGCAL signal selects self-calibration time. Initially this bit set as “0” it means short calibration time (about 10 ms). But if first a couple of data were wrong value, user should select long calibration time (about 40 ms).

0x8002.9000

7	6		3	2	1	0
ADCPD	DIRECTC		WAIT		SOP	LONGCAL

Bits	Type	Function
7	R/W	ADC power down bit. Write “1” to go ADC power save mode. This bit blocks the clock to ADC, so ADC consumes no power when this bit is set. But after release this bit, ADC need 10 ~ 40 ms calibration time to normal operation.
6	R/W	If this bit was set, CPU access directly ADC through DIRCR and directly read ADC result value through DIRDATA register.
5:4	-	Reserved
3:2	R/W	Select ADC conversion wait time. It is for capture timing of the data from ADC to internal register. 00: no wait (read after 16 cycles, default wait time) 01: 2 clock wait (read after 18 cycles) 10: 4 clock wait (read after 20 cycles)
1	R/W	Self Operate Power down bit. When this bit is set, AIOSTOP bit will strobe high when no ADC functions are enabled.
0	R/W	Long calibration time. The default ADC calibration time is 10 ms but when needed ADC can be calibrated during 40ms with this bit. Short calibration time need 96 cycles of 8 kHz OCLK or 128 cycles of 11 kHz OCLK and the long time need 384 cycles of 8 kHz or 512 cycles of 11 kHz OCLK. OCLK is determined from SRATE bit of ADCSDCR.

ADCCR. LONGCAL bit	ADCSCR. SRATE bit	Calibration Time (the number of OCLK cycles)
0	0	96
0	1	128
1	0	383
1	1	511

10.1.2.2 ADC Touch Panel Control Register (ADCTPCR)

This register control functions related with touch panel interface. **HMS30C7210 supports only external drive for touch panel, so prudent setting of this register is needed.**

0x8002.9004

7	6	5	4	3	2	1	0
TPEN	TINTMSK	SWBYPSS	SWINVT	INTTDEN	SSHOT	TRATE	

Bits	Type	Function
7	R/W	Touch panel read enable bit. Write “1” to enable touch panel function.
6	R/W	Touch panel read interrupt mask bit. Write “1” to enable touch panel interrupt.
5	R/W	Touch panel drive signal bypass bit for external drive circuit. You must set this bit to bypass switching signals to external pins such as SW_XP, SW_XN, SW_YP and SW_YN.

4	R/W	Touch panel drive signal inversion bit. for flexibility
3	R/W	Internal tip-down detection logic enable bit. You must write "0" to disable this function.
2	R/W	Single touch panel read operation. Normally, touch panel data read twice. But this bit is set, touch panel data read once for a point and save power to read touch panel.
1:0	R/W	Select touch panel data sampling rate. It depends on basic operation clock of ADC interface(sound sampling rate). 11: 400 or 550 samples / sec 10: 200 or 275 samples / sec 01: 100 or 138 samples / sec 00: 50 or 69 samples / sec

10.1.2.3 ADC Battery check Control Register (ADCBACR)

This registers controls battery check operation.

0x8002.9008

7	6			3	2		
MBEN	MINTMSK			BBEN	BINTMSK		

Bits	Type	Function
7	R/W	Main battery check enable Write "1" to enable Four 8-bit battery check data recorded in ADCMBDATA register
6	R/W	Main battery check interrupt mask bit Write "1" to enable
5:4	-	Reserved
3	R/W	Backup battery check enable Write "1" to enable Four 8-bit battery check data recorded in ADCBBDATA register
2	R/W	Backup battery check interrupt mask bit Write "1" to enable
1:0	-	Reserved

10.1.2.4 ADC Sound Control Register (ADCSDCR)

This registers controls sound sampling function. SRATE bit control base clock of ADC interface logic.

0x8002.900C

7	6						0
SNDEN	SINTMSK						SRATE

Bits	Type	Function
7	R/W	Sound data capture enable bit Write "1" to enable
6	R/W	Sound data interrupt mask bit Write "1" to enable
5:1	-	Reserved
0	R/W	Sound data sampling rate selection bit. This bit affects to all sampling rates of touch panel and battery operations. 0: 8 kHz sound sampling 1: 11.025 kHz sound sampling 8/11KHz is derived from ack (3.6864MHz) called as "PCLK" in SLOW APB.

10.1.2.5 ADC Interrupt Status Register (ADCISR)

Read only valid but write "1" to clear all interrupt value

0x8002.9010

7	6	5	4			1	0
INTTP	INTMB	INTBB	INTSD			INTTD	INTTU

Bits	Type	Function
7	R/W	Touch panel data interrupt. Write "1" here to clear this interrupt.
6	R/W	Main battery checks interrupt. Write "1" here to clear this interrupt.
5	R/W	Backup battery check interrupt. Write "1" to clear this interrupt.
4	R/W	Sound data interrupt. It will be generated when all the 8 sound registers are full. Write "1" here to clear this interrupt.
3:2	-	Reserved
1	R/W	Tip Down interrupt. Write "1" here to clear this interrupt.
0	R/W	Tip Up interrupt. Write "1" here to clear this interrupt.

10.1.2.6 ADC Tip Down Control Status Register (ADCTDCSR)

0x8002.901C

7	6	5	4	3	2	1	0
TDEN	TDMSK	TUEN	TUMSK	TPSEL		TP_X	TP_Y

Bits	Type	Function
7	R/W	Touch panel tip-down detection logic enable Write "1" to enable this function
6	R/W	Touch panel tip-down interrupt mask bit Write "1" to enable interrupt
5	R/W	Touch panel tip-up detection enable. When this bit is set, once in every 20 OCLK cycles, monitor touch panel status periodically.
4	R/W	Touch panel tip-up interrupt mask bit.
3	R/W	Select Tip Down/Up monitoring channel (0:X, 1:Y)
2	-	Reserved
1	R/W	X axis Tip status monitor bit (read only bit)
0	R/W	Y axis Tip status monitor bit (read only bit)

10.1.2.7 ADC Direct Control Register (ADCDIRCR)

ADC I/F has the Direct Data Read Function. When DIRECTC bit in ADCCR register is set high, CPU can access directly A/D Converter through this register and can read conversion data of A/D Converter through DIRDATA register.

0x8002.9020

7	6	5	4	3	2	1	0
AIOSTOP			ACH				

Bits	Type	Function
7	R/W	AIOSTOP bit value to access ADC directly
6:5	-	Reserved
4:0	R/W	ADC channel selection bits to control ADC directly 00001: select channel 0 (touch panel X) 00010: select channel 1 (touch panel Y) 00100: select channel 2 (Main battery) 01000: select channel 3 (Backup battery) 10000: select channel 4 (Sound input)

10.1.2.8 ADC Direct Data Read Register (ADCDIRDATA)

Register can be used to read data from ADC.

0x8002.9024

9	8	7	6	5	4	3	2	1	0
AD Data									

Bits	Type	Function
9:0	R	10-bit AD conversion data

10.1.2.9 ADC 1ST Touch Panel Data register

0x8002.9030 – 0x8002.903C

31	30	29	28	27	26	25	24	23	22	21	20	19	18	17	16
15	14	13	12	11	10	9	8	7	6	5	4	3	2	1	0

XDATA1: ADCTPXDR0, XDATA3: ADCTPXDR1
 YDATA1: ADCTPYDR0, YDATA3: ADCTPYDR1
 XDATA0: ADCTPXDR0, XDATA2: ADCTPXDR1
 YDATA0: ADCTPYDR0, YDATA2: ADCTPYDR1

ADCTPXDR0: 0x80029030

Bits	Type	Function
31:26	-	Reserved
25:16	R	Touch panel X data 10-bit, 2/4 of the first sample cycle (XDATA1)
15:10	-	Reserved
9:0	R	Touch panel X data 10-bit, 1/4 of the first sample cycle (XDATA0)

ADCTPXDR1: 0x80029034

Bits	Type	Function
31:26	-	Reserved
25:16	R	Touch panel X data 10-bit, 4/4 of the first sample cycle (XDATA3)
15:10	-	Reserved
9:0	R	Touch panel X data 10-bit, 3/4 of the first sample cycle (XDATA2)

ADCTPYDR0: 0x80029038

Bits	Type	Function
31:26	-	Reserved
25:16	R	Touch panel Y data 10-bit, 2/4 of the first sample cycle (YDATA1)
15:10	-	Reserved
9:0	R	Touch panel Y data 10-bit, 1/4 of the first sample cycle (YDATA0)

ADCTPYDR1: 0x8002903C

Bits	Type	Function
31:26	-	Reserved
25:16	R	Touch panel Y data 10-bit, 4/4 of the first sample cycle (YDATA3)
15:10	-	Reserved
9:0	R	Touch panel Y data 10-bit, 3/4 of the first sample cycle (YDATA2)

10.1.2.10 ADC 2ND Touch Panel Data Register

0x8002.9040 – 0x8002.904C

31	30	29	28	27	26	25	24	23	22	21	20	19	18	17	16
15	14	13	12	11	10	9	8	7	6	5	4	3	2	1	0

XDATA5: ADCTPXDR2, XDATA7: ADCTPXDR3
 YDATA5: ADCTPYDR2, YDATA7: ADCTPYDR3
 XDATA5: ADCTPXDR2, XDATA6: ADCTPXDR3
 YDATA5: ADCTPYDR2, YDATA6: ADCTPYDR3

ADCTPXDR2: 0x80029040

Bits	Type	Function
31:26	-	Reserved
25:16	R	Touch panel X data 10-bit, 2/4 of the second sample cycle (XDATA5)
15:10	-	Reserved
9:0	R	Touch panel X data 10-bit, 1/4 of the second sample cycle (XDATA4)

ADCTPXDR3: 0x80029044

Bits	Type	Function
31:26	-	Reserved
25:16	R	Touch panel X data 10-bit, 4/4 of the second sample cycle (XDATA7)
15:10	-	Reserved
9:0	R	Touch panel X data 10-bit, 3/4 of the second sample cycle (XDATA6)

ADCTPYDR2: 0x80029048

Bits	Type	Function
31:26	-	Reserved
25:16	R	Touch panel Y data 10-bit, 2/4 of the second sample cycle (YDATA5)
15:10	-	Reserved
9:0	R	Touch panel Y data 10-bit, 1/4 of the second sample cycle (YDATA4)

ADCTPYDR3: 0x8002904C

Bits	Type	Function
31:26	-	Reserved
25:16	R	Touch panel Y data 10-bit, 4/4 of the second sample cycle (YDATA7)
15:10	-	Reserved
9:0	R	Touch panel Y data 10-bit, 3/4 of the second sample cycle (YDATA6)

10.1.2.11 ADC Main Battery Data Register (ADCMBDATA)

0x8002.9050

31	30	29	28	27	26	25	24	23	22	21	20	19	18	17	16
MBDATA3								MBDATA2							
15	14	13	12	11	10	9	8	7	6	5	4	3	2	1	0
MBDATA1								MBDATA0							

Bits	Type	Function
31:24	R/W	Forth main battery check data
23:16	R/W	Third main battery check data
15:8	R/W	Second main battery check data
7:0	R/W	First main battery check data

10.1.2.12 ADC Backup Battery Data Register (ADCBBDATA)

0x8002.9054

31	30	29	28	27	26	25	24	23	22	21	20	19	18	17	16
BBDATA3								BBDATA2							
15	14	13	12	11	10	9	8	7	6	5	4	3	2	1	0
BBDATA1								BBDATA0							

Bits	Type	Function
31:24	R/W	Forth backup battery check data
23:16	R/W	Third backup battery check data
15:8	R/W	Second backup battery check data
7:0	R/W	First backup battery check data

10.1.2.13 ADC Sound Data Register (ADCSDATA0 – ADCSDATA7)

HMS30C7202 has 8-word size sound register so it can contain 32 8-bit sound data. In ADC interface logic, there are 8-byte(2-word) temporal buffer for sound data and every 2-word write into SDATA0,1 / SDATA2,3 / SDATA4,5 / SDATA6,7 at a time (at end of every "all 8-byte temporal buffer full")

time). So, user has to read in 8 x (one sample period) second for getting valid ADCSDATA0,1(1st 2-word) after Sound interrupt.

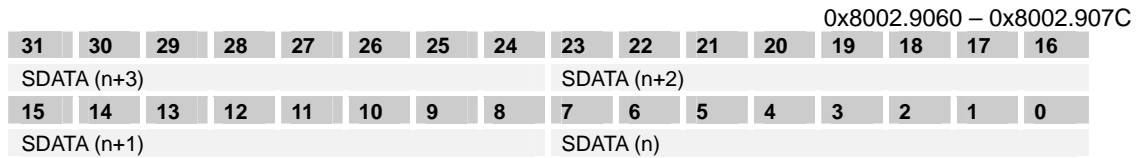

Bits	Type	Function
31:24	R/W	(4n+3) TH Sound Data. (n = ADCSDATAn)
23:16	R/W	(4n+2) TH Sound Data. (n = ADCSDATAn)
15:8	R/W	(4n+1) TH Sound Data. (n = ADCSDATAn)
7:0	R/W	(4n) TH Sound Data. (n = ADCSDATAn)

10.2 GPIO

This document describes the Programmable Input /Output module (PIO). This is an AMBA slave module that connects to the Advanced Peripheral Bus (APB). For more information about AMBA, please refer to the AMBA Specification (ARM IHI 0001).

The I/O status is not changed during “Sleep mode” or “Deep Sleep mode”.

10.2.1 External Signals

Pin Name	Type	Description
KSCANI [7:0]	I/O	GPIO PORTA [15:8]
KSCANO [7:0]	I/O	GPIO PORTA [7:0]
PORTB [11:6]	I/O	GPIO PORTB [11:6] PORTB[11:10] : dedicated to the external interrupt of PMU
nUDCD0	I/O	GPIO PORTB [5]
nUDSR0	I/O	GPIO PORTB [4]
nURTS0	I/O	GPIO PORTB [3]
nUCTS0	I/O	GPIO PORTB [2]
nUDTR0	I/O	GPIO PORTB [1]
nURING0	I/O	GPIO PORTB [0]
nRCS3	I/O	GPIO PORTC [10]
nRCS2	I/O	GPIO PORTC [9]
nDMAACK	I/O	GPIO PORTC [8]
nDMAREQ	I/O	GPIO PORTC [7]
PWM1	I/O	GPIO PORTC [6]
PWM0	I/O	GPIO PORTC [5]
PS2CK	I/O	GPIO PORTC [4]
PS2D	I/O	GPIO PORTC [3]
PORTC[2]	I/O	GPIO PORTC [2]
PORTC[1]	I/O	GPIO PORTC [1]
TimerOut	I/O	GPIO PORTC [0]
LBLEN	I/O	GPIO PORTD [8]
LD [15:8]	I/O	GPIO PORTD [7:0]
RA [24]	I/O	GPIO PORTE [24]
PORTE[23]	I/O	GPIO PORTE [23]
PORTE[22]	I/O	GPIO PORTE [22]
MMCLK	I/O	GPIO PORTE [21]
MMCCD	I/O	GPIO PORTE [20]
MMCDAT	I/O	GPIO PORTE [19]
MMCCMD	I/O	GPIO PORTE [18]
nRW3	I/O	GPIO PORTE [17]
nRW2	I/O	GPIO PORTE [16]
RD [31:16]	I/O	GPIO PORTE [15:0]

10.2.2 Registers

Address	Name	Width	Default	Description
0x8002.3000	ADATA	16	0x0000	GPIO PORTA Data register
0x8002.3004	ADIR	16	0xFFFF	GPIO PORTA Data Direction register
0x8002.3008	AMASK	16	0x0000	GPIO PORTA Interrupt Mask register
0x8002.300C	ASTAT	16	0x0000	GPIO PORTA Interrupt Status register
0x8002.3010	AEDGE	16	0x0000	GPIO PORTA Edge Mode register
0x8002.3014	ACLIR	16	0x0000	GPIO PORTA Clear register
0x8002.3018	APOL	16	0x0000	GPIO PORTA Polarity register
0x8002.301C	AEN	16	0x0000	GPIO PORTA Enable register
0x8002.3020	BDATA	12	0x0000	GPIO PORTB Data register
0x8002.3024	BDIR	12	0xFFFF	GPIO PORTB Data Direction register

0x8002.3028	BMASK	12	0x000	GPIO PORTB Interrupt Mask register
0x8002.302C	BSTAT	12	0x000	GPIO PORTB Interrupt Status register
0x8002.3030	BEDGE	12	0x000	GPIO PORTB Edge Moderegister
0x8002.3034	BCLR	12	0x000	GPIO PORTB Clear register
0x8002.3038	BPOL	12	0x000	GPIO PORTB Polarity register
0x8002.303C	BEN	6	0x00	GPIO PORTB Enable register
0x8002.3040	CDATA	11	0x000	GPIO PORTC Data register
0x8002.3044	CADIR	11	0x7FF	GPIO PORTC Data Direction register
0x8002.3048	CMASK	11	0x000	GPIO PORTC Interrupt Mask register
0x8002.304C	CSTAT	11	0x000	GPIO PORTC Interrupt Status register
0x8002.3050	CEDGE	11	0x000	GPIO PORTC Edge Mode register
0x8002.3054	CCLR	11	0x000	GPIO PORTC Clear register
0x8002.3058	CPOL	11	0x000	GPIO PORTC Polarity register
0x8002.305C	CEN	11	0x000	GPIO PORTC Enable register
0x8002.3060	DDATA	9	0x000	GPIO PORTD Data register
0x8002.3064	DDIR	9	0x1FF	GPIO PORTD Data Direction register
0x8002.3068	DMASK	9	0x000	GPIO PORTD Interrupt Mask register
0x8002.306C	DSTAT	9	0x000	GPIO PORTD Interrupt Status register
0x8002.3070	DEEDGE	9	0x000	GPIO PORTD Edge Mode register
0x8002.3074	DCLR	9	0x000	GPIO PORTD Clear register
0x8002.3078	DPOL	9	0x000	GPIO PORTD Polarity register
0x8002.307C	DEN	9	0x000	GPIO PORTD Enable register
0x8002.3080	EDATA	25	0x0000000	GPIO PORTE Data register
0x8002.3084	EDIR	25	0x1FFFFFF	GPIO PORTE Data Direction register
0x8002.3088	EMASK	25	0x0000000	GPIO PORTE Interrupt Mask register
0x8002.308C	ESTAT	25	0x0000000	GPIO PORTE Interrupt Status register
0x8002.3090	EEDGE	25	0x0000000	GPIO PORTE Edge Mode register
0x8002.3094	ECLR	25	0x0000000	GPIO PORTE Clear register
0x8002.3098	EPOL	25	0x0000000	GPIO PORTE Polarity register
0x8002.309C	EEN	25	0x0000000	GPIO PORTE Enable register
0x8002.30A0	TICTMDR	1	0x0	GPIO Tic Test Mode register
0x8002.30A4	AMULSEL	16	0x0000	GPIO PORTA Multi-function Select register
0x8002.30A8	SWAP	1	0x0	SWAP Pin Configuration register

10.2.2.1 ADATA

0x8002.3000

15	14	13	12	11	10	9	8	7	6	5	4	3	2	1	0
ADATA, ADIR, AMASK, ASTAT, AEDGE, ACLR, APOL, AEN [15:0]															

Bits	Type	Function
16	R/W	Values written to this register will be output on port [A,B,C,D,E] pins if the corresponding data direction bits are set Low (port output). Values read from this register reflect the external state of port [A,B,C,D,E] not necessarily the value written to it. All bits are cleared by a system reset. When the PIO pin is defined as input, this input can be an interrupt source with register setting. On reads, the Data Register contains the current status of correspondent port pins, whether they are configured as input or output. Writing to a Data Register only affects the pins that are configured as outputs. All PIO input pins can be used as interrupt source with enabled interrupt mask register bit. These interrupt sources can be selected as active HIGH/LOW, EDGE/LEVEL trigger mode.

10.2.2.2 ADIR

0x8002.3004

Bits	Type	Function
16	R/W	Bits set in this register will select the corresponding pin in port [A,B,C,D,E] to become an input, clearing a bit sets the pin to output. All bits are set by a system reset.

10.2.2.3 AMASK

0x8002.3008

Bits	Type	Function
16	R/W	Bits set in this register will select the corresponding pin to become an interrupt source. All bits are cleared by a system reset. 0 = disable interrupt (default) 1 = enable interrupt

10.2.2.4 ASTAT

0x8002.300C

Bits	Type	Function
16	RO	All PIO signals can be used as interrupt sources according to the settings. Each port has the following registers and the interrupt signals to interrupt controller. Interrupt controller receives active HIGH, level mode interrupt sources only. But PIO block can receive not only active HIGH or active LOW, but also level or edge mode signals. Then it interprets and sends interrupt request to the interrupt controller. All bits can be controlled separately. Values in this 16-bit read-only register represents that the interrupt requests are pending on corresponding pins. All bits are cleared by a system reset. 0 = no interrupt request 1 = interrupt pending (masked interrupt is always 0)

10.2.2.5 AEDGE

0x8002.3010

Bits	Type	Function
16	R/W	Bits set in this 16-bit read/write register will select the corresponding pin to become an edge mode interrupt source. All bits are cleared by a system reset. 0 = level mode (default) 1 = edge mode

10.2.2.6 ACLR

0x8002.3014

Bits	Type	Function
16	WO	Bits set in this 16-bit write-only register will clear the stored interrupt request of corresponding bit in edge mode. All bits are automatically cleared after written. 0 = no action (default) 1 = clear interrupt source (self reset)

10.2.2.7 APOL

0x8002.3018

Bits	Type	Function
16	R/W	Bits set in this 16-bit read/write register will select the corresponding pin to become an active LOW mode interrupt source. All bits are cleared by a system reset. After accessing this register, the Edge Mode register should be cleared with the Clear register. 0 = active HIGH mode 1 = active LOW mode

10.2.2.8 GPIO PORT A Enable Register

15	14	13	12	11	10	9	8
PORTA15	PORTA14	PORTA13	PORTA12	PORTA11	PORTA10	PORTA9	PORTA8
7	6	5	4	3	2	1	0
PORTA7	PORTA6	PORTA5	PORTA4	PORTA3	PORTA2	PORTA1	PORTA0

0x8002.301C

Bits	Type	Function
15	R/W	GPIO PORT A[15] Enable 1: PORT A[15] 0: KSCAN0[7]

14	R/W	GPIO PORT A[14] Enable	1: PORT A[14]	0: KSCAN0[6]
13	R/W	GPIO PORT A[13] Enable	1: PORT A[13]	0: KSCAN0[5]
12	R/W	GPIO PORT A[12] Enable	1: PORT A[12]	0: KSCAN0[4]
11	R/W	GPIO PORT A[11] Enable	1: PORT A[11]	0: KSCAN0[3]
10	R/W	GPIO PORT A[10] Enable	1: PORT A[10]	0: KSCAN0[2]
9	R/W	GPIO PORT A[9] Enable	1: PORT A[9]	0: KSCAN0[1]
8	R/W	GPIO PORT A[8] Enable	1: PORT A[8]	0: KSCAN0[0]
7	R/W	GPIO PORT A[7] Enable	1: PORT A[7]	0: KSCANI[7]
6	R/W	GPIO PORT A[6] Enable	1: PORT A[6]	0: KSCANI[6]
5	R/W	GPIO PORT A[5] Enable	1: PORT A[5]	0: KSCANI[5]
4	R/W	GPIO PORT A[4] Enable	1: PORT A[4]	0: KSCANI[4]
3	R/W	GPIO PORT A[3] Enable	1: PORT A[3]	0: KSCANI[3]
2	R/W	GPIO PORT A[2] Enable	1: PORT A[2]	0: KSCANI[2]
1	R/W	GPIO PORT A[1] Enable	1: PORT A[1]	0: KSCANI[1]
0	R/W	GPIO PORT A[0] Enable	1: PORT A[0]	0: KSCANI[0]

10.2.2.9 BDATA

											0x8002.3020
11	10	9	8	7	6	5	4	3	2	1	0
BDATA, BDIR, BMASK, BSTAT, BEDGE, BCLR, BPOL, BEN											

10.2.2.10 BDIR

0x8002.3024

10.2.2.11 BMASK

0x8002.3028

10.2.2.12 BSTAT

0x8002.302C

10.2.2.13 BEDGE

0x8002.3030

10.2.2.14 BCLK

0x8002.3034

10.2.2.15 BPOL

0x8002.3038

10.2.2.16 GPIO PORT B Enable Register

7	6	5	4	3	2	1	0
Reserved		PORTB5	PORTB4	PORTB3	PORTB2	PORTB1	PORTB0

0x8002.303C

Bits	Type	Function
5	R/W	GPIO PORT B[5] Enable 1: PORT B[5] 0: nUDCD
4	R/W	GPIO PORT B[4] Enable 1: PORT B[4] 0: nUDSR
3	R/W	GPIO PORT B[3] Enable 1: PORT B[3] 0: nURTS
2	R/W	GPIO PORT B[2] Enable 1: PORT B[2] 0: nUCTS
1	R/W	GPIO PORT B[1] Enable 1: PORT B[1] 0: nUDTR
0	R/W	GPIO PORT B[0] Enable 1: PORT B[0] 0: nURING

10.2.2.17 CDATA

											0x8002.3040
10	9	8	7	6	5	4	3	2	1	0	
CDATA, CDIR, CMASK, CSTAT, CEDGE, CCLR, CPOL, CEN											

10.2.2.18 CDIR

0x8002.3044

<i>10.2.2.19 CMASK</i>	0x8002.3048
<i>10.2.2.20 CBSTAT</i>	0x8002.304C
<i>10.2.2.21 CEDGE</i>	0x8002.3050
<i>10.2.2.22 CCLK</i>	0x8002.3054
<i>10.2.2.23 CPOL</i>	0x8002.3058
<i>10.2.2.24 GPIO PORT C Enable Register</i>	0x8002.305C

15	14	13	12	11	10	9	8
Reserved						PORTC10	PORTC9
7	6	5	4	3	2	1	0
PORTC7	PORTC6	PORTC5	PORTC4	PORTC3	PORTC2	PORTC1	PORTC0

0x8002.305C

Bits	Type	Function
10	R/W	GPIO PORT C[10] Enable 1: PORT C[10] 0: nRCS3
9	R/W	GPIO PORT C[9] Enable 1: PORT C[9] 0: nRCS2
8	R/W	GPIO PORT C[8] Enable 1: PORT C[8] 0: nDMAACK
7	R/W	GPIO PORT C[7] Enable 1: PORT C[7] 0: nDMAREQ
6	R/W	GPIO PORT C[6] Enable 1: PORT C[6] 0: PWM1
5	R/W	GPIO PORT C[5] Enable 1: PORT C[5] 0: PWM0
4	R/W	GPIO PORT C[4] Enable 1: PORT C[4] 0: PS2CK
3	R/W	GPIO PORT C[3] Enable 1: PORT C[3] 0: PS2D
2	R/W	GPIO PORT C[2] Enable 1: PORT C[2] 0:Reserved
1	R/W	GPIO PORT C[1] Enable 1: PORT C[1] 0:Reserved
0	R/W	GPIO PORT C[0] Enable 1: PORT C[0] 0: TimerOut

<i>10.2.2.25 DDATA</i>	0x8002.3060
------------------------	-------------

8	7	6	5	4	3	2	1	0
DDATA, DDIR, DMASK, DSTAT, DEDGE, DCLR, DPOL, DEN								

<i>10.2.2.26 DDIR</i>	0x8002.3064
<i>10.2.2.27 DMASK</i>	0x8002.3068
<i>10.2.2.28 DBSTAT</i>	0x8002.306C
<i>10.2.2.29 DEDGE</i>	0x8002.3070
<i>10.2.2.30 DCLK</i>	0x8002.3074
<i>10.2.2.31 DPOL</i>	0x8002.3078
<i>10.2.2.32 GPIO PORT D Enable Register</i>	0x8002.3078

15	14	13	12	11	10	9	8
Reserved							PORTD8
7	6	5	4	3	2	1	0
PORTD7	PORTD6	PORTD5	PORTD4	PORTD3	PORTD2	PORTD1	PORTD0

Bits	Type	Function
0	R/W	When TicSel is HIGH, there is 3 Port registers (B, D, F) access to check up special word. TicSelWR is enabling the TICTMDR and PSTB is clock signal. So TicSel data output is PD[0] bit.

10.2.2.42 PORTA Multi-function Select register(AMULSEL)

0x8002.30A4

15	14	13	12	11	10	9	8	7	6	5	4	3	2	1	0
AMULSEL															

Bits	Type	Function
15	R/W	GPIO PORT A[15] Multi-function Select 1: IRIN 0: GPIO or Primary
14	R/W	GPIO PORT A[14] Multi-function Select 1: USOUT3 0: GPIO or Primary
13	R/W	GPIO PORT A[13] Multi-function Select 1: USIN3 0: GPIO or Primary
12	R/W	GPIO PORT A[12] Multi-function Select 1: ISECK 0: GPIO or Primary
11	R/W	GPIO PORT A[11] Multi-function Select 1: ISWS 0: GPIO or Primary
10	R/W	GPIO PORT A[10] Multi-function Select 1: PORT A[10] output 0: GPIO or Primary
9	R/W	GPIO PORT A[9] Multi-function Select 1: PORT A[9] output 0: GPIO or Primary
8	R/W	GPIO PORT A[8] Multi-function Select 1: PORT A[8] output 0: GPIO or Primary
7	R/W	GPIO PORT A[7] Multi-function Select 1: IROUT 0: GPIO or Primary
6	R/W	GPIO PORT A[6] Multi-function Select 1: USOUT2 0: GPIO or Primary
5	R/W	GPIO PORT A[5] Multi-function Select 1: USIN2 0: GPIO or Primary
4	R/W	GPIO PORT A[4] Multi-function Select 1: ISCLK 0: GPIO or Primary
3	R/W	GPIO PORT A[3] Multi-function Select 1: ISD 0: GPIO or Primary
2	R/W	GPIO PORT A[2] Multi-function Select 1: PORT A[2] output 0: GPIO or Primary
1	R/W	GPIO PORT A[1] Multi-function Select 1: PORT A[1] output 0: GPIO or Primary
0	R/W	GPIO PORT A[0] Multi-function Select 1: PORT A[0] output 0: GPIO or Primary

10.2.2.43 SWAP Pin Configuration Register(SWAP)

0x8002.30A8

															0
															SWAP

Bits	Type	Function
0	R/W	SWAP determines PORT E Pin configuration. When reset, USB transceiver signals, SMC and RA24 will be available. Otherwise, USB transceiver, SMC will be available while RA 24 cannot be used so addressing space reduced by half.

10.2.3 GPIO Interrupt

GPIO has 7 interrupt sources. Each port can be configured as 1 interrupt source except port B. To use a GPIO port as interrupt source, specify edge register polarity register according to interrupt type, for example, low level sensitive or rising edge sensitive, etc. then set mask register to enable interrupt. Port B has 3 interrupt sources, PORTB[11], PORTB[10] and PORTB[9:0]. PORTB[11] is assigned to make CPU go to deep sleep mode, PORTB[10] is to detect Hotsync. PORTB[9:0] is used as general GPIO interrupt source. So, following chart shows available GPIO interrupts.

Interrupt Name	Configurable Bits
GPIOINTR	PORTA[15:0]
GPIOB0INTR	PORTB[10], Hotsync Interrupt
GPIOB1INTR	PORTB[11], Deep Sleep Interrupt
GPIOBINTR	PORTB[9:0]
GPIOCINTR	PORTC[10:0]
GPIODINTR	PORTD[8:0]
GPIOEINTR	PORTE[24:0]

10.2.4 GPIO Rise/Fall Time

Data output, unit : ns

Port number	50pF		100pF		150pF	
	Rise	Fall	Rise	Fall	Rise	Fall
A0~15, B0~11, C0~10, D0~8, E22~23 (*Group A)	8.745	10.687	15.946	19.917	23.136	29.147
E0~17,24 (Group B)	6.098	5.693	10.896	10.317	15.696	14.927
E18~21 (Group C)	4.018	4.048	6.904	7.137	9.783	10.217

* It means the drive strength (Group A = 1, Group B = 2, Group C = 4)

10.3 Interrupt Controller

The HMS30C7202 has a fully programmable priority, individually maskable, vectored interrupt controller. This feature reduces the software overhead in handling interrupts. The Interrupt controller can trigger the Fast interrupt request (NFIQ) and the standard interrupt request (NIRQ) from any interrupt source (on-chip peripherals and GPIOs). The fully programmable priority encoder allows the user to define the priority of each interrupt source. External interrupt sources can be positive or negative edge triggered or high or low level sensitive, depending on the value programmed in the EDGE and POL registers (see GPIO registers).

ID Code	Interrupt Source	ID Code	Interrupt Source
00	PMU	10	Timer1 or Timer2 or Timer3(64Bit)
01	DMA	11	Watchdog
02	LCD	12	Reserved
03	Sound	13	Reserved
04	Reserved	14	GPIOB0 (GPIOB [10])
05	USB	15	GPIOB1 (GPIOB [11])
06	MMC	16	GPIOA
07	RTC	17	GPIOB
08	UART0	18	GPIOC
09	UART1	19	GPIOD
0A	UART2	1A	GPIOE
0B	UART3	1B	ARM core (COMMRX debug only)
0C	KBD (KeyBoard Interface)	1C	ARM core (COMMTX debug only)
0D	PS2	1D	SmartMedia Card
0E	AIC	1E	Software (auto generation by CPU register set)
0F	Timer0		

Table 10-2 Interrupt controller Configuration

Note The inputs GPIOB [10] and GPIOB [11] have internally a de-bouncing logic, which allows the direct connection to a button (e.g. for deep sleep and Hot Sync.).

10.3.1 Block diagram

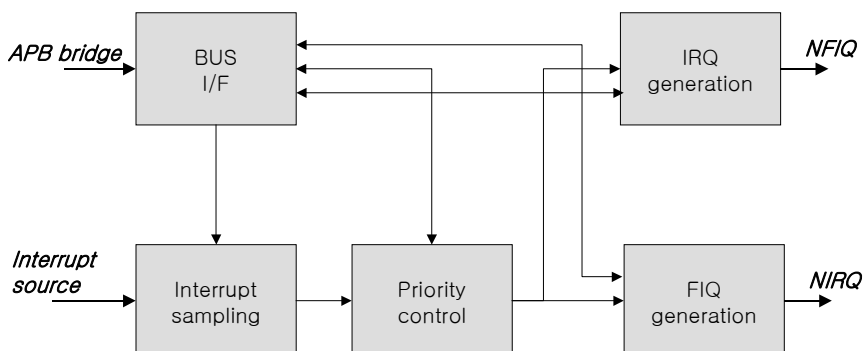

Figure 10-1 Interrupt controller block diagram

10.3.2 Registers

Address	Name	Width	Default	Description
0x8002.4000	IER	31	0x00000000	Interrupt enable register
0x8002.4004	ISR	31	0x00000000	Interrupt status register
0x8002.4008	IVR	32	0x00000000	IRQ vector register

0x8002.4010	SVR0	32	0x00000000	Source vector register 0
0x8002.4014	SVR1	32	0x00000000	Source vector register 1
0x8002.4018	SVR2	32	0x00000000	Source vector register 2
0x8002.401C	SVR3	32	0x00000000	Source vector register 3
0x8002.4020	SVR4	32	0x00000000	Source vector register 4
0x8002.4024	SVR5	32	0x00000000	Source vector register 5
0x8002.4028	SVR6	32	0x00000000	Source vector register 6
0x8002.402C	SVR7	32	0x00000000	Source vector register 7
0x8002.4030	SVR8	32	0x00000000	Source vector register 8
0x8002.4034	SVR9	32	0x00000000	Source vector register 9
0x8002.4038	SVR10	32	0x00000000	Source vector register 10
0x8002.403C	SVR11	32	0x00000000	Source vector register 11
0x8002.4040	SVR12	32	0x00000000	Source vector register 12
0x8002.4044	SVR13	32	0x00000000	Source vector register 13
0x8002.4048	SVR14	32	0x00000000	Source vector register 14
0x8002.404C	SVR15	32	0x00000000	Source vector register 15
0x8002.4050	SVR16	32	0x00000000	Source vector register 16
0x8002.4054	SVR17	32	0x00000000	Source vector register 17
0x8002.4058	SVR18	32	0x00000000	Source vector register 18
0x8002.405C	SVR19	32	0x00000000	Source vector register 19
0x8002.4060	SVR20	32	0x00000000	Source vector register 20
0x8002.4064	SVR21	32	0x00000000	Source vector register 21
0x8002.4068	SVR22	32	0x00000000	Source vector register 22
0x8002.406C	SVR23	32	0x00000000	Source vector register 23
0x8002.4070	SVR24	32	0x00000000	Source vector register 24
0x8002.4074	SVR25	32	0x00000000	Source vector register 25
0x8002.4078	SVR26	32	0x00000000	Source vector register 26
0x8002.407C	SVR27	32	0x00000000	Source vector register 27
0x8002.4080	SVR28	32	0x00000000	Source vector register 28
0x8002.4084	SVR29	32	0x00000000	Source vector register 29
0x8002.4088	SVR30	32	0x00000000	Source vector register 30
0x8002.4090	IDR	32	0x00001F1F	Interrupt ID register
0x8002.4094	PSR0	32	0x03020100	Priority set register 0
0x8002.4098	PSR1	32	0x07060504	Priority set register 1
0x8002.409C	PSR2	32	0x0B0A0908	Priority set register 2
0x8002.40A0	PSR3	32	0x0F0E0D0C	Priority set register 3
0x8002.40A4	PSR4	32	0x13121110	Priority set register 4
0x8002.40A8	PSR5	32	0x17161514	Priority set register 5
0x8002.40AC	PSR6	32	0x1B1A1918	Priority set register 6
0x8002.40B0	PSR7	32	0x001E1D1C	Priority set register 7

Table 10-3 Interrupt controller Register Summary

10.3.2.1 Interrupt Enable Register (IER)

This register is used to enable/disable the interrupt request of interrupt sources.

0x8002.4000

Bits	Type	Function
31	R/W	0 : enable FIQ for priority 0 interrupts , 1 : disable FIQ (a priority 0 interrupt will trigger IRQ)
30	R/W	Software Interrupt
29	R/W	SmartMedia Card
28	R/W	ARM core (COMMTX: debug only)
27	R/W	ARM core (COMMRX: debug only)
26	R/W	GPIO port E
25	R/W	GPIO port D
24	R/W	GPIO port C
23	R/W	GPIO port B
22	R/W	GPIO port A
21	R/W	External Interrupt1 (GPIOB[11])
20	R/W	External Interrupt0 (GPIOB[10])

19	R/W	Reserved
18	R/W	Reserved
17	R/W	Watchdog timer
16	R/W	Timer1 or Timer2 or Timer3(64Bit)
15	R/W	Timer0
14	R/W	AIC
13	R/W	PS2
12	R/W	KBD (keyboard interface)
11	R/W	UART3
10	R/W	UART2
9	R/W	UART1
8	R/W	UART0
7	R/W	RTC
6	R/W	MMC
5	R/W	USB
4	R/W	Reserved
3	R/W	Sound
2	R/W	LCD
1	R/W	DMA
0	R/W	PMU

Note

0: Disable interrupt / 1: Enable interrupt

The interrupt signals of Timer 1, 2, and 3 are merged into one interrupt source in Timer Block. So, you can use these ORed signal as one interrupt source.

10.3.2.2 Interrupt Status Register (ISR)

The IRQ Status register indicates whether or not the interrupt source has triggered an IRQ interrupt.

0x8002.4004

Bits	Type	Function
31	R/O	Reserved
30	R/O	Software Interrupt
29	R/O	SmartMedia Card
28	R/O	ARM core (COMMTX: debug only)
27	R/O	ARM core (COMMRX: debug only)
26	R/O	GPIO port E
25	R/O	GPIO port D
24	R/O	GPIO port C
23	R/O	GPIO port B
22	R/O	GPIO port A
21	R/O	External Interrupt1 (GPIOB[11])
20	R/O	External Interrupt0 (GPIOB[10])
19	R/O	Reserved
18	R/O	Reserved
17	R/O	Watchdog timer
16	R/O	Timer1 or Timer2 or Timer3(64Bit)
15	R/O	Timer0
14	R/O	AIC
13	R/O	PS2
12	R/O	KBD (keyboard interface)
11	R/O	UART3
10	R/O	UART2
9	R/O	UART1
8	R/O	UART0
7	R/O	RTC
6	R/O	MMC
5	R/O	USB
4	R/O	Reserved
3	R/O	Sound

2	R/O	LCD
1	R/O	DMA
0	R/O	PMU

Note

0: No interrupt requested (or interrupt source is disabled)

1: Interrupt pending

10.3.2.3 IRQ Vector Register (IVR)

31	...	0	0x8002.4008
IVR			

Bits	Type	Function
31:0	R	The IRQ Vectored Register contains the vector programmed by the user in the Source Vector Register corresponding to the current interrupt. The Source Vector Register (0 to 31) is indexed using the ID number in the current interrupt ID register when the IRQ Vector Register is read. When there is no IRQ status, the IRQ Vector Register is set to 0.

10.3.2.4 Source Vector Register (SVR0 to SVR30)

31	...	0	0x8002.4010 ~ 0x8002.4088
IVR			

Bits	Type	Function
31:0	R/W	The user may store in these registers the address of the corresponding handler for each interrupt source. This interrupt controller has 31-Source Vector Registers, which are corresponded to ID code. For example the Source Vector Register of the Interrupt by RTC is the SVR7 (Source Vector Register 7)

10.3.2.5 Interrupt ID Register (IDR)

The Interrupt ID Register returns the current FIQ and IRQ interrupt source number.

31 - 13	12 - 8	7 - 5	4 - 0	0x8002.4090
Reserved	FIQID	Reserved	IRQID	

Bits	Type	Function
31:13	R	Reserved
12:8	R	FIQID
7:5	R	Reserved
4:0	R	IRQID

10.3.2.6 Priority Set Register (PSR0 to PSR7)

The Priority Set Registers consist of 8 registers, representing 32 priority levels. Each interrupt source (see table 10-2) has its (unique) priority level. The FIQ interrupt source is defined in PSR0[7:0], e.g. if PSR0[7:0] = 0x09, UART 1 can trigger the FIQ interrupt.

31 - 24	23 - 16	15 - 8	7 - 0	0x8002.4094 ~ 0x8002.40B0
IRQ priority *	IRQ priority *	IRQ priority *	IRQ priority *	

Register	Bits	Type	Initial ID value	Function
PSR7	31:24	R	0x00	Reserved
	23:16	R/W	0x1E	IRQ priority 1E
	15:8	R/W	0x1D	IRQ priority 1D
	7:0	R/W	0x1C	IRQ priority 1C
PSR6	31:24	R/W	0x1B	IRQ priority 1B
	23:16	R/W	0x1A	IRQ priority 1A

	15:8	R/W	0x19	IRQ priority 19
	7:0	R/W	0x18	IRQ priority 18
PSR5	31:24	R/W	0x17	IRQ priority 17
	23:16	R/W	0x16	IRQ priority 16
	15:8	R/W	0x15	IRQ priority 15
	7:0	R/W	0x14	IRQ priority 14
PSR4	31:24	R/W	0x13	IRQ priority 13
	23:16	R/W	0x12	IRQ priority 12
	15:8	R/W	0x11	IRQ priority 11
	7:0	R/W	0x10	IRQ priority 10
PSR3	31:24	R/W	0x0F	IRQ priority F
	23:16	R/W	0x0E	IRQ priority E
	15:8	R/W	0x0D	IRQ priority D
	7:0	R/W	0x0C	IRQ priority C
PSR2	31:24	R/W	0x0B	IRQ priority B
	23:16	R/W	0x0A	IRQ priority A
	15:8	R/W	0x09	IRQ priority 9
	7:0	R/W	0x08	IRQ priority 8
PSR1	31:24	R/W	0x07	IRQ priority 7
	23:16	R/W	0x06	IRQ priority 6
	15:8	R/W	0x05	IRQ priority 5
	7:0	R/W	0x04	IRQ priority 4
PSR0	31:24	R/W	0x03	IRQ priority 3
	23:16	R/W	0x02	IRQ priority 2
	15:8	R/W	0x01	IRQ priority 1
	7:0	R/W	0x00	IRQ priority 0 or FIQ source *

Note

The Priority Level is to be defined as follows.

IRQ Priority 0 or **FIQ source** > IRQ Priority 1 > IRQ Priority 2 > . . . > IRQ Priority 1D> IRQ Priority 1E

* Disable Interrupt Type Bit(IER Bit31): **FIQ source** / Enable Interrupt Type Bit(IER Bit31) : IRQ priority 0

10.4 Matrix Keyboard Interface Controller

The Matrix keyboard interface controller is an AMBA slave module that connects to the Advanced Peripheral Bus (APB). For more information about AMBA, please refer to the AMBA Specification (ARM IHI 0001). The interface controller is designed to communicate with the external keyboard. The keyboard interface uses the pins KSCANI [7:0], KSCANO [7:0]. It is possible to select one of four scan clock modes.

FEATURES

- Four scanning modes
- 8x8 Matrix
- Byte key buffers

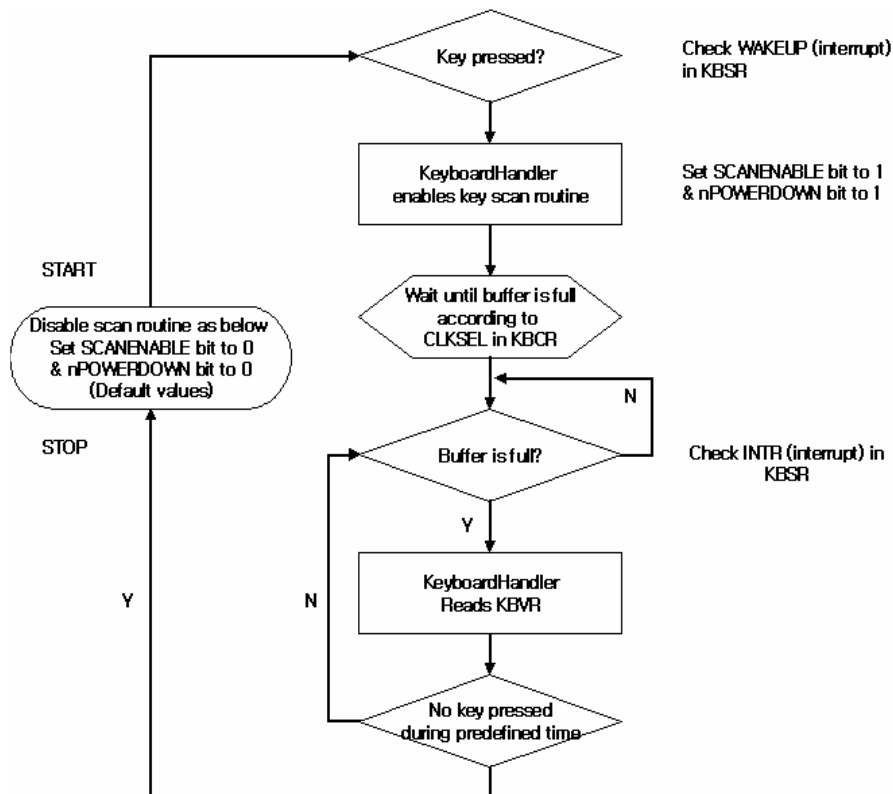

Figure 10-2 A flow chart of the keyboard controller

10.4.1 External Signals

Pin Name	Type	Description
KSCANO [7:0]	O	This assigns the x-axis' scan line. The value is changed periodically so as to cover every key matrix. During one keyboard scan, KSCANO [7:0] can have 8 different values. Active LOW signal.
KSCANI [7:0]	I	This indicates which key is pressed in the assigned scan line. Active LOW signal

10.4.2 Registers

Address	Name	Width	Default	Description
0x8002.2000	KBCR	8	0x0	Keyboard Configuration register
0x8002.2004	KBSC	8	0x0	Keyboard Scanout register

0x8002.2008	KBTR	8	0x0	Keyboard Test register
0x8002.200C	KBVR0	32	0x0	Keyboard value register 0
0x8002.2010	KBVR1	32	0x0	Keyboard value register 1
0x8002.2018	KBSR	1	0x0	Keyboard status register

Table 10-4 Matrix Keyboard Interface Controller Register Summary
10.4.2.1 Keyboard Configuration Register (KBCR)

			0x8002.2000
7			2
1			0
SCAN ENABLE			nPOWER DOWN CLK SEL
Bits	Type	Function	
7	R/W	SCANENABLE bit. This starts or stops matrix keyboard scanning. To start keyboard input scanning, set the SCANENABLE bit and nPOWERDOWN bit of KBCR (Keyboard Configuration Register) and the CLK SEL bit of the KBCR. The key scan control signal is generated. Periodically, column scan code is saved in the 8byte key buffer. After the 8th column key data is stored, keyboard interrupt is generated to make the CPU read 8 scan values. The SCANENABLE bit and nPOWERDOWN bit are usually set or reset simultaneously. When all the column of keyboard has been scanned, an interrupt is generated, and, by interrogating the KBVR registers, software can determine which keys have been pressed. It is software's responsibility to debounce the key pressed information. Keyboard key press interrupts are generated in all PMU states except deep sleep. Start and stop scanning 0 = stop 1 = start	
6:3	-	Reserved. Keep these bits to zero.	
2	R/W	nPOWERDOWN bit. In the power down mode, no clock is inputted to this controller logic. 0 = power down mode, where clock is not operating 1 = normal mode, where clock is operating	
1:0	R/W	CLKSEL bit. This controls the operating clock of scanning matrix keyboard. Base Scanning clock is generated using PCLK (3.6864MHz).	
		Value	Base Scanning Clock Rate Scan Rate (8byte column buffer)
		00	PCLK/2 (1.84MHz, test mode only) 8861 times/sec
		01	PCLK/128 (28KHz) 138 times/sec
		10	PCLK/256 (14KHz) 69 times/sec
		11	PCLK/512 (7KHz) 34 times/sec

10.4.2.2 Keyboard Scanout Register(KBSC)

			0x8002.2004
Bits	Initial	Function	
7	0	0 = 1 st line will be scanned 1 = no scan	
6	0	0 = 2 nd line will be scanned 1 = no scan	
5	0	0 = 3 rd line will be scanned 1 = no scan	
4	0	0 = 4 th line will be scanned 1 = no scan	
3	0	0 = 5 th line will be scanned 1 = no scan	
2	0	0 = 6 th line will be scanned 1 = no scan	
1	0	0 = 7 th line will be scanned 1 = no scan	

0	0	0 = 8 th line will be scanned 1 = no scan
---	---	---

10.4.2.3 Keyboard Test Register (KBTR)

0x8002.2008

Bits	Initial	Function
7	1	Indicates whether 1 st key in the selected scan column is pressed 0 = pressed, 1 = not pressed
6	1	Indicates whether 2 nd key in the selected scan column is pressed 0 = pressed, 1 = not pressed
5	1	Indicates whether 3 rd key in the selected scan column is pressed 0 = pressed, 1 = not pressed
4	1	Indicates whether 4 th key in the selected scan column is pressed 0 = pressed, 1 = not pressed
3	1	Indicates whether 5 th key in the selected scan column is pressed 0 = pressed, 1 = not pressed
2	1	Indicates whether 6 th key in the selected scan column is pressed 0 = pressed, 1 = not pressed
1	1	Indicates whether 7 th key in the selected scan column is pressed 0 = pressed, 1 = not pressed
0	1	Indicates whether 8 th key in the selected scan column is pressed 0 = pressed, 1 = not pressed

10.4.2.4 Keyboard Value Register (KBVR0)

0x8002.200C

31	30	29	28	27	26	25	24	23	22	21	20	19	18	17	16
1st column KSCANI [7:0]								2nd column KSCANI [7:0]							
15	14	13	12	11	10	9	8	7	6	5	4	3	2	1	0
3rd column KSCANI [7:0]								4th column KSCANI [7:0]							

Bits	Type	Function
31:24	R	1st column matrix keyboard scan input data. For example, if the value of KBVR0[32:24] is 00001100, the 5th and 6th keys are pressed and the others are released in 1st column.
23:16	R	2nd column matrix keyboard scan input data
15:8	R	3rd column matrix keyboard scan input data
7:0	R	4th column matrix keyboard scan input data

10.4.2.5 Keyboard Value Register (KBVR1)

0x8002.2010

31	30	29	28	27	26	25	24	23	22	21	20	19	18	17	16
5th column KSCANI [7:0]								6th column KSCANI [7:0]							
15	14	13	12	11	10	9	8	7	6	5	4	3	2	1	0
7th column KSCANI [7:0]								8th column KSCANI [7:0]							

Bits	Type	Function
31:24	R	5th column matrix keyboard scan input data
23:16	R	6th column matrix keyboard scan input data
15:8	R	7th column matrix keyboard scan input data
7:0	R	8th column matrix keyboard scan input data

10.4.2.6 Keyboard Status Register (KBSR)

0x8002.2018

																1	0
																WAKEUP	INTR

Bits	Type	Function
------	------	----------

7:2	-	Reserved
1	R	The interrupt and the KBSR bit are cleared after the CPU reads KBSR. The WAKEUP bit is set if any key is pressed when SCANENABLE bit is inactive. Wake up state: 0 = no key pressed or scan enabled 1 = key pressed when scan disabled
0	R	Key bufferstate: 0 = key buffer is not full 1 = key buffer is full

10.5 PS/2 Interface Controller

This PS/2 Controller is an Advanced Microcontroller Bus Architecture (AMBA) compliant System-on-a-Chip peripheral providing industry-standard PS/2 data transfer channel. A channel has two bi-directional signals that serve as direct interfaces to an external keyboard, mouse or any other PS/2-compatible pointing device. This is an AMBA slave module that connects to the Advanced Peripheral Bus (APB). For more information about AMBA, please refer to the AMBA Specification (ARM IHI 0001).

FEATURES

- AMBA compliant
- PS/2 compatible interface
- Half-duplex bi-directional synchronous serial interface using open-drain outputs for clock and data
- Enable/Disable channel
- Operation in polled or interrupt-driven mode
- Hardware support for PS/2 auxiliary device protocol
- Maskable transmit and receive interrupts
- Automatic odd parity generation and checking
- Optional software based PS/2 implementation
- Test Interface Controller compatible test registers and test modes

10.5.1 External Signals

Pin Name	Type	Description
PSCLK	I/O	PS/2 compatible clock signal pin. Pull-up this pad output (open-drain pad used.)
PSDAT	I/O	PS/2 compatible data signal pin. Also pull-up this pad (open-drain).

10.5.2 Registers

Address	Name	Width	Default	Description
0x8002.C000	PSDATA	8	00h	Transmit/Receive data register
0x8002.C004	PSSTAT	7	00h	Internal status register
0x8002.C008	PSCONF	6	00h	Configuration register
0x8002.C00C	PSINTR	5	00h	Interrupt/Error status and Interrupt ACK register
0x8002.C010	PSTDLO	8	00h	Timing parameter register
0x8002.C014	PSTPRI	8	00h	Timing parameter register
0x8002.C018	PSTXMT	8	00h	Timing parameter register
0x8002.C020	PSTREC	8	00h	Timing parameter register
0x8002.C024	PSTIC0	1		Test Register 0
0x8002.C024	PSTIC1	8		Test Register 1
0x8002.C024	PSTIC2	8		Test Register 2
0x8002.C024	PSTIC3	8		Test Register 3
0x8002.C024	PSTIC4	8		Test Register 4
0x8002.C024	PSTIC5	8		Test Register 5
0x8002.C03C	PSPWDN	1	00h	Power-down configuration register

Table 10-5 PS/2 Controller Register Summary

NOTE: The initial value of registers may be not correct with the condition of testing environment. Above values are based on TIC test environment. With external model, some registers may have different value.

10.5.2.1 PSDATA

7	6	5	4	3	2	1	0	0x8002.C000
Transmit / Receive Data								
Bits	Type	Function						
7:0	R/W	After wake up, PS/2 interface waits for one of two events:						

1. If data is written to the PSDATA register, a transmit sequence is initiated and the data is transmitted serially.
 2. If data signal is pulled low by the external devices and clock signal's negative edge is detected, a receive sequence begins and data is clocked into PSDATA register.
- At the end of transmission, transmit interrupt will occur. By reading PSSTAT status register will reveal the data is transmitted properly. Reading PSSTAT also de-asserts transmit interrupt request.
- PS/2 controller usually remains in receive data mode if no data is transmitting. The controller automatically receives data from external device and generates receive interrupt. By just reading PSDATA register the data will be acquired and the receive interrupt will be cleared.

10.5.2.2 PSSTAT

0x8002.C004

	6	5	4	3	2	1	0
	PARITY	DATA IN	CLK IN	RX BUSY	RX FULL	TX BUSY	TX EMPTY

Bits	Type	Function
7	-	Reserved. Always Zero
6	R/O	The parity bit of the last received data byte
5	R/O	Double synchronized value of the current PSDAT being received/transmitted
4	R/O	Double synchronized value of the current PSCLK being received/transmitted
3	R/O	This bit indicates that the PS/2 controller is currently receiving data or not
2	R/O	This bit indicates that the a data is received and ready to be read
1	R/O	This bit indicates that the PS/2 controller is currently transmitting data or not
0	R/O	This bit indicates that the transmit register is empty and ready to transmit

10.5.2.3 PSCONF

0x8002.C008

	6	5	4	3	2		0
	LCE	FORCE DAT LOW	FORCE CLK LOW	RX INTREN	TX INTREN		ENABLE

Bits	Type	Function
7	-	Reserved
6	R/W	Line Control detection Enable bit. If set, PS/2 controller checks the line control bit from external device following by STOP bit. Otherwise PS/2 controller skips checking line control bit and proceeds to next operation. Default value is zero. Most PS/2 compatible device supports line control bit mechanism. But there are some devices that don't support line control bit. To handle such device, PS/2 controller can skip line control bit detection by resetting this bit.
5	R/W	When set, PSDAT output is forced LOW regardless of the current state of the PS/2 control logic. This mode can be used as manual communication with external device.
4	R/W	When set, PSCLK output is forced LOW regardless of the current state of the PS/2 control logic.
3	R/W	Enable receiver interrupt. To set means enable interrupt. Receiver interrupt is generated whenever PS/2 controller finishes receiving a byte data from external device. Except when transmit data, PS/2 controller goes in receive mode automatically. If receiver interrupt is disabled, PS/2 controller doesn't notify a data received. So polling PSINTR interrupt register is needed.
2	R/W	Enable transmitter interrupt. To set means enable interrupt. Transmitter interrupt is generated whenever PS/2 controller completes to transmit a byte data to external device. If transmitter interrupt is disabled then poll status register to know that the transmitting transaction is completed or poll interrupt register transmitter interrupt is generated.
1	-	Reserved
0	R/W	When reset, PS/2 controller is disabled and gets into deep sleep mode. When set, enabled. To activate PS/2 controller,, first set proper parameters of timing registers and then set this bit. As soon as this bit is enabled, PS/2 controller goes into receive mode by default.

10.5.2.4 PSINTR

0x8002.C00C

			4	3	2	1	0
			TRANSMIT TIMEOUT	RECEIVE TIMEOUT	PARITY ERROR	RX INTR	TX INTR

Bits	Type	Function
7:5	-	Reserved
4	R/O	Set when PS/2 controller fails to send a complete byte data to external device in a given time. The time limit is defined in PSTXMT register. PS/2 controller doesn't try to re-transmit the data. Reset when PSSTAT register is read.
3	R/O	Set when a byte data was not constructed in a certain predefined time limit due to no more bit received or bit-rate is too slow. The time limit is defined in PSTREC register. PSDATA shows the incomplete data that has been received by that time. Reset as soon as the next byte data is arrived.
2	R/O	Set when the last received data has parity error. Cleared when the very next byte data is arrived.
1	R/O	Set when PS/2 controller receives a byte data from external device. Cleared when PSDATA register is read. When PSCONF.RXINTREN is reset, the only way to know that receiver interrupt is generated is to read this bit.
0	R/O	Set when PS/2 controller completes to transmit a byte data to external device. Cleared when PSSTAT register is read. When PSCONF.TXINTREN is reset, poll this bit to confirm that the transmission is completed.

10.5.2.5 PSTDLO

0x8002.C010

7	6	5	4	3	2	1	0
PSTDLO							

Bits	Type	Function
7:0	R/W	t_{PSTDLO} means the period that defines PCLK low period before initiates transmission (A in Figure 10-3 PS/2 Controller Transmitting Data Timing Diagram). Usually the value is 64us. To meet this condition, user must set this timing register properly. $INT(64us/(PCLK \text{ period}) - 1)$ is appropriate value for this register.

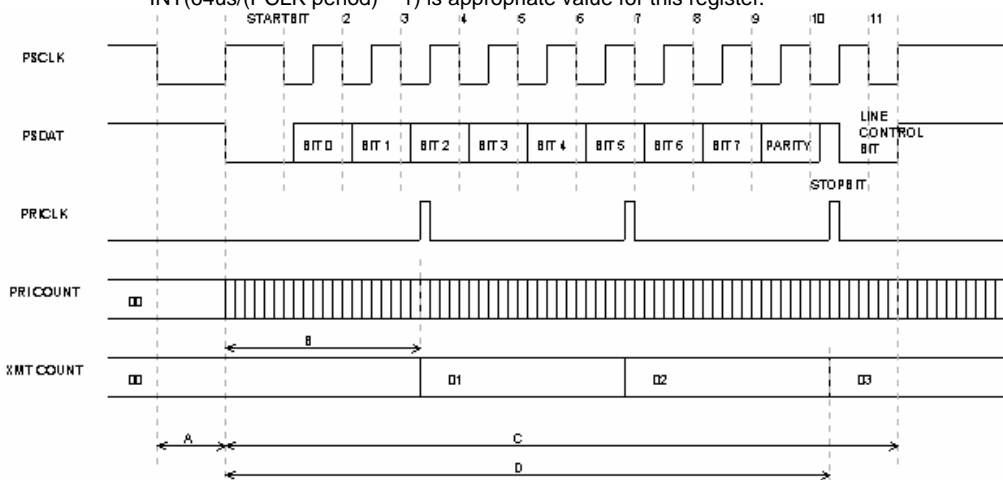

A: t_{PSTDLO} , B: t_{PSTPRI} , C: t_{XMT} , D: t_{PSTXMT}

Figure 10-3 PS/2 Controller Transmitting Data Timing Diagram

10.5.2.6 PSTPRI

0x8002.C014

7	6	5	4	3	2	1	0
PSTPRI							

Bits	Type	Function
7:0	R/W	Every timer in PS/2 controller is clocked by PRICLK except PRI COUNTER that generates PRICLK itself. The reason why uses PRICLK instead of PCLK is that PCLK is too fast so timing check counter requires more bits than slower clock rate. The period of PRICLK is determined by (PSTPRI+1) * that of PCLK.

10.5.2.7 PSTXMT

0x8002.C018

7	6	5	4	3	2	1	0
PSTXMT							

Bits	Type	Function
7:0	R/W	This parameter determines the maximum transmission time. It is calculated as t_{PSTXMT} (D in Figure 10-3 PS/2 Controller Transmitting Data Timing Diagram) = (PSTXMT+1)* t_{PSTPRI} (B in Figure 10-3 PS/2 Controller Transmitting Data Timing Diagram). Error condition is when t_{XMT} (total transmission time, C in Figure 10-3 PS/2 Controller Transmitting Data Timing Diagram) exceeds t_{PSTXMT} . Typical value of max. t_{XMT} is 15ms. So adjust t_{PSTPRI} and t_{PSTXMT} to meet the condition.

10.5.2.8 PSTREC

0x8002.C020

7	6	5	4	3	2	1	0
PSTREC							

Bits	Type	Function
7:0	R/W	This parameter determines the maximum data receiving time. It is calculated as t_{PSTREC} (B in Figure 10-4 PS/2 Controller Receiving Data Timing Diagram) = (PSTREC+1)* t_{PSTPRI} (A in Figure 10-4 PS/2 Controller Receiving Data Timing Diagram). Error condition is when t_{REC} (total receiving time, C in Figure 10-4 PS/2 Controller Receiving Data Timing Diagram) exceeds t_{PSTREC} . Typical value of max. t_{REC} is 15ms. So adjust t_{PSTPRI} and t_{PSTREC} to meet the condition.

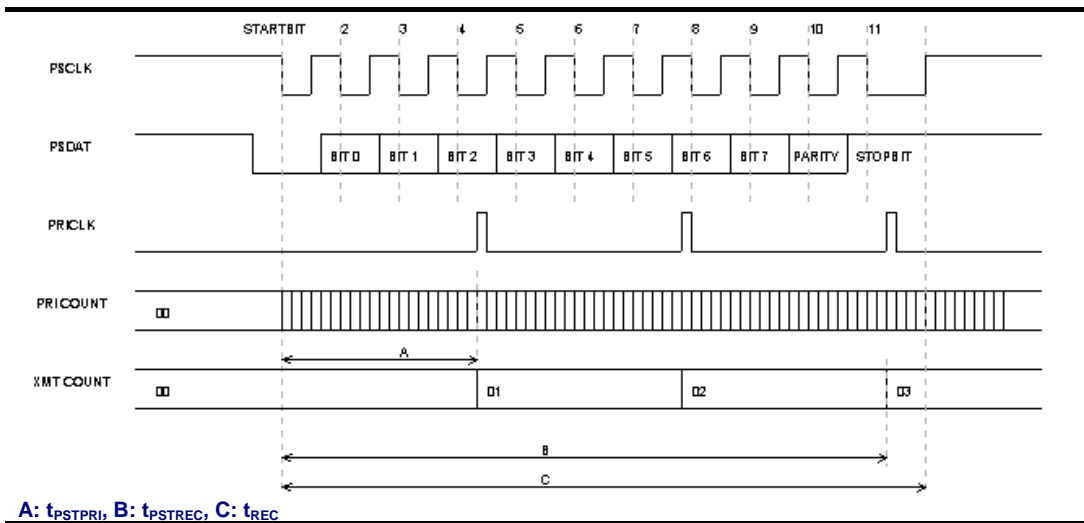
Figure 10-4 PS/2 Controller Receiving Data Timing Diagram

10.6 RTC

This module is a 32-bit counter clocked by a 32768Hz clock. This clock needs to be provided by the system, as there is no crystal inside the block. It also contains a 32-bit match register that can be programmed to generate an interrupt signal when the time in the RTC matches the specific value written to this register (alarm function - RTC event). The RTC has two event outputs, one which is synchronized to PCLK, RTCIRQ, and the second, URTCEV synchronized to the 32768Hz clock. RTCIRQ is connected to the system interrupt controller, and URTCEV is used by the PMU to provide a system alarm Wake up.

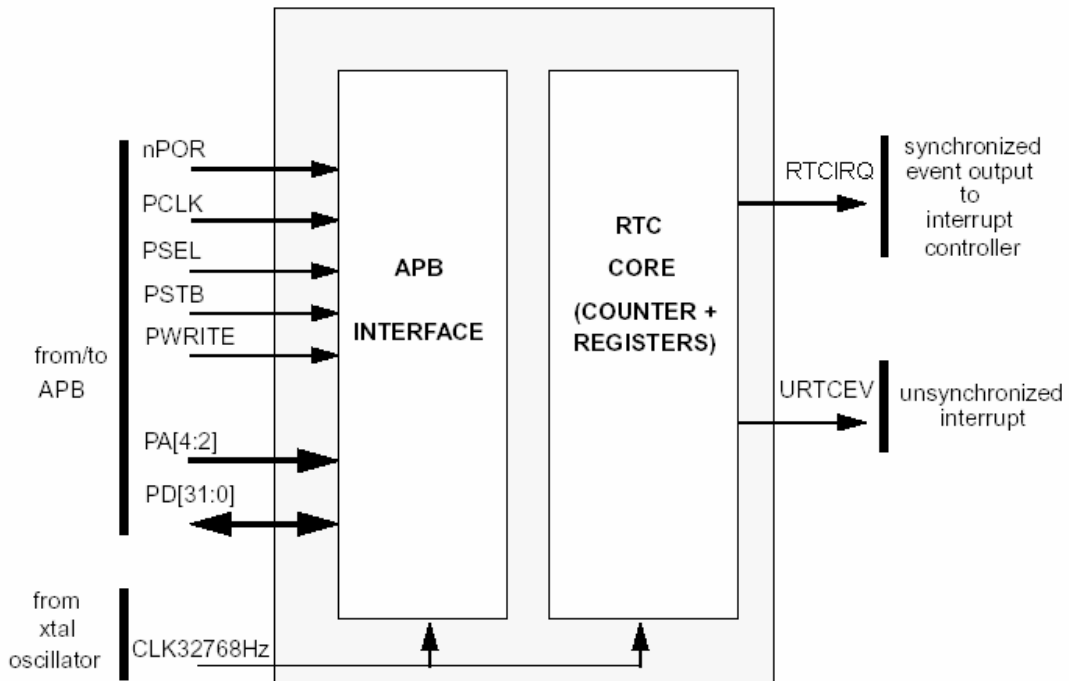

Figure 10-5 RTC Connection

As shown in Fig. 10-3, RTC module is connected to the APB. APB signals are refer to AMBA APB spec, and following table shows the non-AMBA signals from the RTC core block. The following table shows non-AMBA signals within RTC core block for more information about APB signals refer to the AMBA APB spec.

NAME	Source/Destination	Description
CLK32KHZ	Clock generator	32768HZ clock input. This is the signal that clocks the counter during normal operation.
RTCIRQ	APB(Interrupt controller)	Interrupt signal to the interrupt module. When HIGH, this signal indicates a valid comparison between the counter value and the match register. It also indicates 1HZ interval with enable bit in control register.
URTCEV	ASB(PMU)	When HIGH, this signal indicates a valid comparison between the counter value and the match register. This signal is used to wake up the HMS30C7202 when it is in deep sleep mode.

Table 10-6 Non-AMBA Signals within RTC Core Block

FEATURES

- Two type of Alarm function

10.6.1 External Signals

Pin Name	Type	Description
RTCOSCIN	I	RTC oscillator input. 32.768KHz
RTCOSCOUT	O	RTC oscillator output. 32.768KHz

10.6.2 Functional Description

The counter is loaded by writing to the RTC data register. The counter will count up on each rising edge of the 1Hz clock and loops back to 0 when the maximum value(0xFFFFFFFF) is reached. At any moment the counter value can be obtained by reading the RTC data register.

The value of the match register can also be read at any time, and the read does not affect the counter value. The status of the interrupt signal is available in the status register. The status bit is set if a comparator match event has occurred or 1 second has elapsed. Reading from the status register will clear the status register.

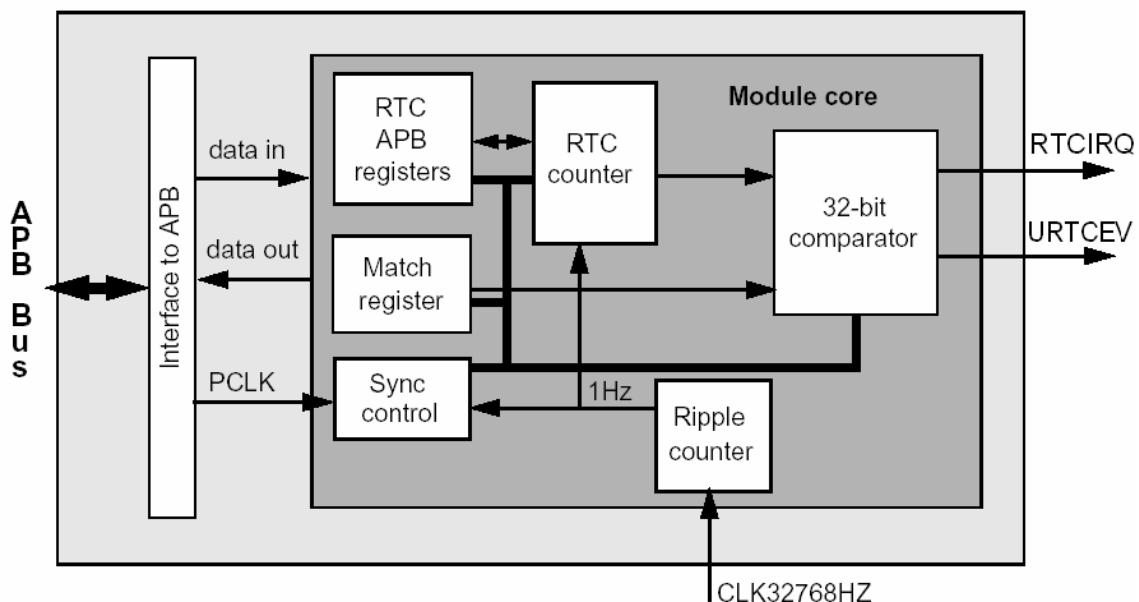

Figure 10-6 RTC Block Diagram

10.6.3 Registers

Address	Name	Width	Default	Description
0x8002.8000	RTCDR	32	0x0	RTC Data Register
0x8002.8004	RTCMR	32	0xF	RTC Match Register
0x8002.8008	RTCSR	2	0x0	RTC Status Register
0x8002.8010	RTCCR	2	0x0	RTC Control Register

Table 10-7 RTC Register Summary

10.6.3.1 RTC Data Register (RTCDR)

Bits	Type	Function
31:0	R/W	RTC Data register. Writing to this 32-bit register will load the counter. A read will give the

10.7 TIMER

This module is a 32-bit counter clocked by a 3.6864MHz clock.

Timer is an AMBA slave module that connects to the Advanced Peripheral Bus (APB). For more information about AMBA, please refer to the AMBA Specification (ARM IHI 0001).

FEATURES

- 32-bit up ripple counter
- Auto repeat mode
- Count enable/disable
- Interrupt enable/disable
- 3-timer channel

10.7.1 External Signals

Pin Name	Type	Description
PWM [1:0]	O	PWM Output
TimerOut	O	Timer 1 output divided by 2

10.7.2 Registers

Address	Name	Width	Default	Description
0x8002.5000	T0BASE	32	0xFFFFFFFF	Timer0 Base Register
0x8002.5008	T0COUNT	32	0x0	Timer0 Counter Register
0x8002.5010	T0CTRL	3	0x0	Timer0 Control Register
0x8002.5020	T1BASE	32	0xFFFFFFFF	Timer1 Base Register
0x8002.5028	T1COUNT	32	0x0	Timer1 Counter Register
0x8002.5030	T1CTRL	3	0x00	Timer1 Control Register
0x8002.5040	T2BASE	32	0xFFFFFFFF	Timer2 Base Register
0x8002.5048	T2COUNT	32	0x0	Timer2 Counter Register
0x8002.5050	T2CTRL	3	0x0	Timer2 Control Register
0x8002.5060	TOPCTRL	32	0x9	Top-level Control Register
0x8002.5064	TOPSTAT	3	0x0	Top-level Status Register
0x8002.5080	T64LOW	32	0x0	Lower 32-bit of 64-bit counter (Timer3)
0x8002.5084	T64HIGH	32	0x0	Upper 32-bit of 64-bit counter (Timer3)
0x8002.5088	T64CTRL	2	0x0	64-bit Timer Control Register (Timer3)
0x8002.508C	T64TR	15	0x0	64-bit Timer Test Register (Timer3)
0x8002.5094	T64LBase	32	0xFFFFFFFF	64-bit Timer Lower Base (Timer3)
0x8002.5098	T64HBase	32	0xFFFFFFFF	64-bit Timer Higher Base (Timer3)
0x8002.50A0	P0COUNT	16	0x0	PWM channel 0 count register
0x8002.50A4	P0WIDTH	16	0xFFFF	PWM channel 0 width register
0x8002.50A8	P0PERIOD	16	0xFFFF	PWM channel 0 period register
0x8002.50AC	P0CTRL	5	0x0	PWM channel 0 control register
0x8002.50B0	P0PWMTR	4	0x0	PWM channel 0 test register
0x8002.50C0	P1COUNT	16	0x0	PWM channel 1 count register
0x8002.50C4	P1WIDTH	16	0xFFFF	PWM channel 1 width register
0x8002.50C8	P1PERIOD	16	0xFFFF	PWM channel 1 period register
0x8002.50CC	P1CTRL	5	0x0	PWM channel 1 control register
0x8002.50D0	P1PWMTR	4	0x0	PWM channel 1 test register

Table 10-8 Timer Register Summary

10.7.2.1 Timer [0,1,2] Base Register (T[0,1,2]BASE)

0x8002.5000 / 0x8002.5020 / 0x8002.5040

31	30	29	28	27	26	25	24	23	22	21	20	19	18	17	16
----	----	----	----	----	----	----	----	----	----	----	----	----	----	----	----

T[0,1,2]BASE [31:16]															
15	14	13	12	11	10	9	8	7	6	5	4	3	2	1	0
T[0,1,2]BASE [15:0]															

Bits	Type	Function
31:0	R/W	Timer 0 (Timer 1, Timer 2) Base Register. 32-bit target count value (interval) is stored in here. The interrupt interval in repeat mode is (Base Register value + 1) clock periods. For example, if the Base Register is set to 0x3333, then the timer generates an interrupt request every 0x3333 + 1 clock cycles.

10.7.2.2 Timer [0,1,2] Count Register (T[0,1,2]COUNT)

0x8002.5008 / 0x8002.5028 / 0x8002.5048

T[0,1,2]COUNT [31:16]															
31	30	29	28	27	26	25	24	23	22	21	20	19	18	17	16
T[0,1,2]COUNT [15:0]															

Bits	Type	Function
31:0	R/W	32bit up counter

10.7.2.3 Timer [0,1,2] Control Register (T[0,1,2]CTRL)

0x8002.5010 / 0x8002.5030 / 0x8002.5050

						2		1		0	
						RESET		REPEAT MODE		COUNT ENABLE	

Bits	Type	Function
7:3	-	Reserved
2	R/W	Set for reset counter register
1	R/W	Set for count repeat mode
0	R/W	Set to start count and reset to stop. For Timer 0, Timer 1, and Timer 2 in non-repeat mode, This bit will be cleared automatically whenever the counter reaches the target value.

10.7.2.4 Timer Top-level Control Register (TOPCTRL)

0x8002.5060

		6		5		4		3		2		1		0	
		TIMER OUT EN		TIMER 64 INTR EN		TIMER 64 ENABLE		POWER DOWN		TIMER 2 INTR EN		TIMER 1 INTR EN		TIMER 0 INTR EN	

Bits	Type	Function
7	-	Reserved
6	R/W	Timer 1 Output Enable. The interval of this output is 2 times of interrupt interval of Timer 1. 0 = disable, 1 = enable
5	R/W	64bit Timer Counter Overflow Interrupt Enable 0 = disable, 1 = enable
4	R/W	64bit Timer Enable. 0 = disable, 1 = enable
3	R/W	Timer Controller POWER DOWN. 0 = Power Down mode, 1 = enable
2	R/W	Timer 2 Interrupt Enable 0 = disable, 1 = enable
1	R/W	Timer 1 Interrupt Enable 0 = disable, 1 = enable
0	R/W	Timer 0 Interrupt Enable. If reset, no interrupt is generated at Timer 0. 0 = disable, 1 = enable

10.7.2.5 Timer Status Register (TOPSTAT)

0x8002.5064

				3	2	1	0
				TIMER 64 INTR	TIMER 2 INTR	TIMER 1 INTR	TIMER 0 INTR

Bits	Type	Function
7:4	-	Reserved
3	R	Timer 64 Interrupt Status Flag
2	R	Timer 2 Interrupt Status Flag
1	R	Timer 1 Interrupt Status Flag
0	R	Timer 0 Interrupt Status Flag

10.7.2.6 Timer Lower 32-bit Count Register of 64-bit Counter (T64LOW)

0x8002.5080

31	30	29	28	27	26	25	24	23	22	21	20	19	18	17	16
T64LOW [31:16]															
15	14	13	12	11	10	9	8	7	6	5	4	3	2	1	0
T64LOW [15:0]															

Bits	Type	Function
31:0	R/W	Lower 32bit count value of 64bit Timer (Timer3)

10.7.2.7 Timer Upper 32-bit Count Register of 64-bit Counter (T64HIGH)

0x8002.5084

31	30	29	28	27	26	25	24	23	22	21	20	19	18	17	16
T64HIGH [31:16]															
15	14	13	12	11	10	9	8	7	6	5	4	3	2	1	0
T64HIGH [15:0]															

Bits	Type	Function
31:0	R/W	Upper 32bit count value of 64bit Timer (Timer3)

10.7.2.8 Timer 64-bit Counter Control Register (T64CTRL)

0x8002.5088

																2	1	0
																RESET		COUNT ENABLE

Bits	Type	Function
7:3	-	Reserved
2	R/W	Reset Timer 64 (Timer3). 0 = Keep Counting, 1 = Reset the counter register
1		Reserved
0	R/W	Timer 64 (Timer3) Enable. 0 = Stop Counter, 1 = Start Counter

10.7.2.9 Timer 64-bit Counter Test Register (T64TR)

0x8002.508C

	14	13	12	11	10	9	8
	Creg59	Creg55	Creg51	Creg47	Creg43	Creg39	Creg35
7	6	5	4	3	2	1	0
Creg31	Creg27	Creg23	CReg19	CReg15	CReg11	CReg7	CReg3

Bits	Type	Function
------	------	----------

14	W	When TestReg[59] is HIGH, output is the same as CountCLK inversion. When TestReg[59] is LOW, output is the same as CountReg[59]
13	W	When TestReg[55] is HIGH, output is the same as CountCLK inversion. When TestReg[55] is LOW, output is the same as CountReg[55]
12	W	When TestReg[51] is HIGH, output is the same as CountCLK inversion. When TestReg[51] is LOW, output is the same as CountReg[51]
11	W	When TestReg[47] is HIGH, output is the same as CountCLK inversion. When TestReg[47] is LOW, output is the same as CountReg[47]
10	W	When TestReg[43] is HIGH, output is the same as CountCLK inversion. When TestReg[43] is LOW, output is the same as CountReg[43]
9	W	When TestReg[39] is HIGH, output is the same as CountCLK inversion. When TestReg[39] is LOW, output is the same as CountReg[39]
8	W	When TestReg[35] is HIGH, output is the same as CountCLK inversion. When TestReg[35] is LOW, output is the same as CountReg[35]
7	W	When TestReg[31] is HIGH, output is the same as CountCLK inversion. When TestReg[31] is LOW, output is the same as CountReg[31]
6	W	When TestReg[27] is HIGH, output is the same as CountCLK inversion. When TestReg[27] is LOW, output is the same as CountReg[27]
5	W	When TestReg[23] is HIGH, output is the same as CountCLK inversion. When TestReg[23] is LOW, output is the same as CountReg[23]
4	W	When TestReg[19] is HIGH, output is the same as CountCLK inversion. When TestReg[19] is LOW, output is the same as CountReg[19]
3	W	When TestReg[15] is HIGH, output is the same as CountCLK inversion. When TestReg[15] is LOW, output is the same as CountReg[15]
2	W	When TestReg[11] is HIGH, output is the same as CountCLK inversion. When TestReg[11] is LOW, output is the same as CountReg[11]
1	W	When TestReg[7] is HIGH, output is the same as CountCLK inversion. When TestReg[7] is LOW, output is the same as CountReg[7]
0	W	When TestReg[3] is HIGH, output is the same as CountCLK inversion. When TestReg[3] is LOW, output is the same as CountReg[3]

10.7.2.10 Timer Lower 32-bit Base Register of 64-bit Counter (T64LBASE)

0x8002.5094

31	30	29	28	27	26	25	24	23	22	21	20	19	18	17	16
T64LBASE [31:16]															
15	14	13	12	11	10	9	8	7	6	5	4	3	2	1	0
T64LBASE [15:0]															
Bits	Type	Function													
31:0	R/W	Lower 32bit base value of 64bit Timer (Timer3)													

10.7.2.11 Timer Upper 32-bit Base Register of 64-bit Counter (T64HBASE)

0x8002.5098

31	30	29	28	27	26	25	24	23	22	21	20	19	18	17	16
T64HBASE [31:16]															
15	14	13	12	11	10	9	8	7	6	5	4	3	2	1	0
T64HBASE [15:0]															
Bits	Type	Function													
31:0	R/W	Upper 32bit base value of 64bit Timer (Timer3)													

10.7.2.12 PWM Channel [0,1] Count Register (P[0,1]COUNT)

0x8002.50A0 / 0x8002.50C0

15	14	13	12	11	10	9	8	7	6	5	4	3	2	1	0
P[0,1]COUNT															
Bits	Type	Function													
15:0	R	PWM [0,1] Count Register													

10.7.2.13 PWM Channel [0,1] Width Register (P[0,1]WIDTH)

0x8002.50A4 / 0x8002.50C4

15	14	13	12	11	10	9	8	7	6	5	4	3	2	1	0
P[0,1]WIDTH															
<hr/>															
Bits	Type	Function													
15:0	R/W	PWM [0,1] Width Register. Actual width of output is (P[0,1]WIDTH + 1) / PCLK.													

10.7.2.14 PWM Channel [0,1] Period Register (P[0,1]PERIOD)

0x8002.50A8 / 0x8002.50C8

15	14	13	12	11	10	9	8	7	6	5	4	3	2	1	0
P[0,1]PERIOD															
<hr/>															
Bits	Type	Function													
15:0	R/W	PWM [0,1] Period Register. Actual Period of output is (P[0,1]PERIOD + 1) / PCLK.													

10.7.2.15 PWM Channel [0,1] Control Register (P[0,1]CTRL)

0x8002.50AC / 0x8002.50CC

				4	3	2	1	0
				CLK SEL	OUTPUT INVERT	OUTPUT ENABLE	RESET	PWM[0,1] ENABLE
<hr/>								
Bits	Type	Function						
7:5	-	Reserved						
4	R/W	PWM [0,1] Source Clock Selection(PCLK) 0 = 3.6864MHz, 1 = 1.8432MHz						
3	R/W	PWM [0,1] Output Waveform Inverting 0 = non inverting, 1 = inverting						
2	R/W	PWM [0,1] Output Enable 0 = disable output driver, 1 = enable output driver						
1	R/W	PWM [0,1] Counter Reset 0 = keep count, 1 = reset counter register						
0	R/W	PWM [0,1] Counter Enable. 0 = stop counter, 1 = start counter						

10.7.2.16 PWM Channel[0,1] Test Register(P[0,1]PWMTR)

0x8002.50B0 / 0x8002.50D0

				3	2	1	0
				Reserved	Creg11	Creg7	Creg3
<hr/>							
Bits	Type	Function					
3		Reserved					
2	W	When TestReg[11] is HIGH, output is the same as CountCLK inversion. When TestReg[11] is LOW, output is the same as CountReg[11]					
1	W	When TestReg[7] is HIGH, output is the same as CountCLK inversion. When TestReg[7] is LOW, output is the same as CountReg[7]					
0	W	When TestReg[3] is HIGH, output is the same as CountCLK inversion. When TestReg[3] is LOW, output is the same as CountReg[3]					

10.8 UART/SIR

The 16C550 is a Universal Asynchronous Receiver/Transmitter (UART), with FIFOs, and is functionally identical to the 16C450 on power-up (CHARACTER mode). The 16550 can be put into an alternate mode (FIFO mode) to relieve the CPU of excessive software overhead. In this mode internal FIFOs are activated, allowing 16 bytes plus 3 bit of error data per byte in the RCVR FIFO, to be stored in both receive and transmit modes. All the logic is on the chip to minimize the system overhead and to maximize efficiency.

The UART performs serial-to-parallel conversion on data characters received from a peripheral device or a MODEM, and parallel-to-serial conversion on data characters received from the CPU. The CPU can read the complete status of the UART at any time during the functional operation. Status information reported includes the type and condition of the transfer operations being performed by the UART, as well as any error conditions (parity, overrun, framing, or break interrupt).

The UART includes a programmable baud rate generator capable of dividing the timing reference clock input by divisors of 1 to $2^{16}-1$, and producing a 16x clock for driving the internal transmitter logic. Provisions are also included to use this 16x clock to drive the receiver logic.

The UART has complete MODEM-control capability, and a processor-interrupt system. Interrupts can be programmed to the user's requirements, minimizing the computing required to handle the communications link.

FEATURES

- Capable of running all existing 16C450 software.
- After reset, all registers are identical to the 16C450 register set.
- The FIFO mode transmitter and receiver are each buffered with 16 byte FIFOs to reduce the number of interrupts presented to the CPU.
- Add or delete standard asynchronous communication bits (start, stop and parity) to or from the serial data.
- Holding and shift registers in the 16C450 mode eliminate the need for precise synchronization between the CPU and serial data.
- Independently controlled transmit, receive, line status and data set interrupts.
- Programmable baud generator divides any input clock by 1 to 65535 and generates 16x clock
- Independent receiver clock input.
- MODEM control functions (CTS, RTS, DSR, DTR, RI and DCD).
- Fully programmable serial-interface characteristics:
 - 5-, 6-, 7- or 8-bit characters
 - Even, odd or no-parity bit generation and detection
 - 1-, 1.5- or 2-stop bit generation and detection
 - Baud generation (DC to 230k baud)
- False start bit detection.
- Complete status-reporting capabilities.
- Line breaks generation and detection.
- Internal diagnostic capabilities:
 - Loopback controls for communications link fault isolation
- Full prioritized interrupt system controls.

10.8.1 External Signals

Pin Name	Type	Description
nURING	I	<p>UART 0 ring input signal (wake-up signal to PMU).</p> <p>When LOW, this indicates that the MODEM or data set has received a telephone ring signal. The nURING signal is a MODEM status input whose condition can be tested by the CPU reading bit 6 (RI) of the MODEM Status Register. Bit 6 is the complement of the nURING signal. Bit 2 (TERI) of the MODEM Status Register indicates whether the nURING input signal has changed from a LOW to a HIGH state since the previous reading of the MODEM Status Register.</p> <p>Note: Whenever the RI bit of the MODEM Status Register changes from a HIGH to a LOW state, an interrupt is generated if the MODEM Status Interrupt is enabled. The nURING input from the external PAD is not provided. To use this signal, you should set up the UART control register of the AFE interface. For further information, refer to 13.9 Analog Front End, AFE (CODEC Interface) on</p>

			page 13-56.
nUDTR	O		UART 0 data terminal ready. When LOW, this informs the MODEM or data set that the UART is ready to establish communication link. The nUDTR output signal can be set to an active LOW by programming bit 0 (DTR) of the MODEM Control Register to HIGH level. A Master Reset operation sets this signal to its inactive (HIGH) state. Loop mode operation holds this signal in its inactive state.
nUCTS	I		UART 0 clear to send input. When LOW, this indicates that the MODEM or data set is ready to exchange data. The nUCTS signal is a MODEM status input whose conditions can be tested by the CPU reading bit 4 (CTS) of the MODEM Status Register indicates whether the nUCTS input has changed state since the previous reading of the MODEM Status Register. nUCTS has no effect on the Transmitter. Note: Whenever the CTS bit of the MODEM Status Register changes its state, an interrupt is generated if the MODEM Status Interrupt is enabled.
nURTS	O		UART 0 request to send. When LOW, this informs the MODEM or data set that the UART is ready to exchange data. The nURTS output signal can be set to an active LOW by programming bit 1 (RTS) of the MODEM Control Register. A Master Reset operation sets this signal to its inactive (HIGH) state. Loop mode operation holds this signal in its inactive state.
nUDSR	I		UART 0 data set ready input. When LOW, this indicates that the MODEM or data set is ready to establish the communications link with the UART. The nUDSR signal is a MODEM status input whose conditions can be tested by the CPU reading bit 5 (DSR) of the MODEM Status Register. Bit 5 is the complement of the nUDSR signal. Bit 1(DDSR) of MODEM Status Register indicates whether the nUDSR input has changed state since the previous reading of the MODEM status register. Note: Whenever the DSR bit of the MODEM Status Register changes its state, an interrupt is generated if the MODEM Status Interrupt is enabled.
nUDCD	I		UART 0 data carrier detect input. When LOW, indicates that the data carrier has been detected by the MODEM data set. The signal is a MODEM status input whose condition can be tested by the CPU reading bit 7 (DCD) of the MODEM Status Register. Bit 7 is the complement of the signal. Bit 3 (DDCD) of the MODEM Status Register indicates whether the input has changed state since the previous reading of the MODEM Status Register. nUDCD has no effect on the receiver. Note: Whenever the DCD bit of the MODEM Status Register changes its state, an interrupt is generated if the MODEM Status Interrupt is enabled.
USIN [0]	I		UART 0 serial data inputs. Serial data input from the communications link (peripheral device, MODEM or data set).
USOUT [0]	O		UART 0 serial data outputs. Composite serial data output to the communications link (peripheral, MODEM or data set). The USOUT signal is set to the Marking (logic 1) state upon a Master Reset operation.
USIN [1]	I		UART 1 serial data inputs
USOUT [1]	O		UART 1 serial data outputs
USIN [2]	I		UART 2 serial data inputs (muxed with KSCAN05)
USOUT [2]	O		UART 2 serial data outputs (muxed with KSCAN06)
USIN [3]	I		UART 3 serial data inputs (muxed with KSCAN15)
USOUT [3]	O		UART 3 serial data outputs (muxed with KSCAN16)

10.8.2 Registers

Address	Name	Width	Default	Description
0x8002.0000	U0Base	-	-	UART 0 Base
0x8002.1000	U1Base	-	-	UART 1 Base
0x8002.D000	U2Base	-	-	UART 2 Base
0x8002.E000	U3Base	-	-	UART 3 Base
UxBase+0x00	RBR	8	0x0	Receiver Buffer Register (DLAB = 0, Read)
	THR			Transmitter Holding Register (DLAB = 0, Write)

	DLL			Divisor Latch Least Significant Byte (DLAB = 1)
UxBase+0x04	IER	8	0x0	Interrupt Enable Register (DLAB = 0)
	DLM			Divisor Latch Most Significant Byte (DLAB = 1)
UxBase+0x08	IIR	8	0x1	Interrupt Identification Register (Read)
	FCR		0x0	FIFO Control Register (Write)
UxBase+0x0C	LCR	8	0x0	Line Control Register
UxBase+0x10	MCR	3	0x0	Modem Control Register
UxBase+0x14	LSR	8	0x60	Line Status Register
UxBase+0x18	MSR	8	0xX0	Modem Status Register
UxBase+0x1C	SCR	8	0x0	Scratch Register
UxBase+0x30	UartEN	1 or 4	0x0	UART Enable Register In Uart 1, this bit width is 4 (support SIR)

Table 10-9 UART/SIR Register Summary

10.8.2.1 RBR/THR/DLL

							UxBase+0x00
7	6	5	4	3	2	1	0
Data Bit 7 ~ Data Bit 0 (RBR, THR; DLAB = 0)							
Bit 7 ~ Bit 0 (DLL; DLAB = 1)							
Bits	Type	Function					
7:0	R/W	When DLAB = 0, read this register represents RBR while writes does THR. When DLAB = 1, DLL will be read or written.					

10.8.2.2 IER/DLM

This register enables the five types of UART interrupts. Each interrupt can individually activate the interrupt (INTUART) output signal. It is possible to totally disable the interrupt Enable Register (IER). Similarly, setting bits of the IER register to logic 1 enables the selected interrupt(s). Disabling an interrupt prevents it from being indicated as active in the IIR and from activating the INTUART output signal. All other system functions operate in their normal manner, including the setting of the Line Status and MODEM Status Registers. Table 13-6: Summary of registers on page 13-10 shows the contents of the IER. Details on each bit follow.

							UxBase+0x04
7	6	5	4	3	2	1	0
0	0	0	0	MS INTR	LS INTR	TX EMPTY INTR	DATA RDY INTR
Bit 7 ~ Bit 0 DLM; (DLAB = 1)							
Bits	Type	Function					
							DLM
7	R/W	0					
6	R/W	0					
5	R/W	0					
4	R/W	0					
3	R/W	Enables the MODEM Status Interrupt when set to logic 1.					
2	R/W	Enables the Receiver Line Status Interrupt when set to logic 1.					
1	R/W	Enables the Transmitter Holding Register Empty Interrupt when set to logic 1.					
0	R/W	Enables the Received Data Available Interrupt (and time-out interrupts in the FIFO mode) when set to logic 1.					

10.8.2.3 IIR/FCR

							UxBase+0x08
7	6	5	4	3	2	1	0

FIFO EN	0	0	INTR ID			INTR PEND
RCVR TRIG LEVEL	-	-	-	XMIT RESET	RCVR RESET	FIFO EN

Interrupt Identification Register

In order to provide minimum software overhead during data character transfers, the UART prioritizes interrupts into four levels and records these in the Interrupt Identification Register. The four levels of interrupt conditions are, in order of priority

1. Receiver Line Status
2. Received Data Ready
3. Transmitter Holding Register Empty
4. MODEM Status

When the CPU accesses the IIR, the UART freezes all interrupts and indicates the highest priority pending interrupt to the CPU. While this CPU access is occurring, the UART records new interrupts, but does not change its current indication until the access is complete.

Bits	Type	Function
7:6	R	These two bits are set when FCR [0] = 1.
5:4	R	These two bits of the IIR are always logic 0
3:1	R	These two bits of the IIR are used to identify the highest priority interrupt pending. In the 16C450 mode, IIR [3] is 0. In the FIFO mode, IIR [3] is set along with IIR [2] when a time-out interrupt is pending

IIR [3:1] Interrupt Set and Reset Function

Priority Level
Interrupt Type
Interrupt Source
Interrupt Reset Control

000

-

None

None

-

011

Highest

Receiver Line Status

Overrun Error or Parity Error or Framing Error or Break Interrupt

Reading the Line Status Register

010

Second

Receiver Data Available

Receiver Data Available or Trigger Level Reached

Reading the Receiver Buffer Register or the FIFO drops below the trigger level

110

Second

Character Time-out Indication

No Characters have been removed from or input to the RCVR FIFO during the last 4 Character times and there is at least 1 Character in it during this time

Reading the Receiver Buffer Register

		001 Third Transmitter Holding Register Empty Transmitter Holding Register Empty Reading the IIR Register (if source of interrupt) or writing into the Transmitter Holding Register
		000 Fourth MODEM Status Clear to Send or Data Set Ready or Ring Indicator or Data Carrier Detect Reading the MODEM Status Register
0	R	This bit can be used in a prioritized interrupt environment to indicate whether an interrupt is pending. When bit 0 is logic 0, an interrupt is pending and the IIR contents may be used as a pointer to the appropriate interrupt service routine. When bit 0 is logic 1, no interrupt is pending

FIFO Control Register

This is a write-only register at the same location as the IIR (the IIR is a read-only register). This register is used to enable the FIFOs, clear the FIFOs and set the RCVR FIFO trigger level.

Bits	Type	Function
7:6	W	These two bits sets the trigger level for the RCVR FIFO interrupt
		Value RCVR FIFO Trigger Level (Bytes)
		00 01
		01 04
		10 08
		11 14
5:3	-	Reserved
2	W	Writing 1 resets the transmitter FIFO counter logic to 0. The shift register is not cleared. The 1 that is written to this bit position is self-clearing
1	W	Writing 1 resets the receiver FIFO counter logic to 0. The shift register is not cleared. The 1 that is written to this bit position is self-clearing
0	W	Writing 1 enables both the XMIT and RCVR FIFOs. Resetting FCR0 will clear all bytes in both FIFOs. When changing from FIFO Mode to 16C450 Mode and vice versa, data is automatically cleared from the FIFOs. This bit must be a 1 when other FCR bits are written to or they will not be programmed

10.8.2.4 LCR

The system programmer specifies the format of the asynchronous data communications exchange and set the Divisor Latch Access bit via the Line Control Register (LCR). The programmer can also read the contents of the Line Control Register. The read capability simplifies system programming and eliminates the need for separate storage in system memory of the line characteristics.

7	6	5	4	3	2	1	0
DLAB	SET BREAK	STICK PARITY	EVEN PARITY	PARITY ENABLE	STOPBIT NUMBER	WORD SELECT	LENGTH
UxBase+0x0C							
Bits	Type	Function					
7		This bit is the Divisor Latch Access Bit (DLAB). It must be set HIGH (logic 1) to access the Divisor Latches of the Baud Generator during a Read or Write operation. It must be set LOW (logic 0) to access the Receiver Buffer, the Transmitter Holding Register or the Interrupt Enable Register					
6		This bit is the Break Control bit. It causes a break condition to be transmitted to the receiving					

		UART. When it is set to logic 1, the serial output (SOUT) is forced to the Spacing (logic 0) state. The break is disabled by setting logic 0. The Break Control bit acts only on SOUT and has no effect on the transmitter logic. Note: This feature enables the CPU to alert a terminal in a computer communications system. If the following sequence is followed, no erroneous or extraneous characters will be transmitted because of the break.										
5		This bit is the Stick Parity bit. When bits 3, 4 and 5 are logic 1 the Parity bit is transmitted and checked as logic 0. If bits 3 and 5 are 1 and bit 4 is logic 0 then the Parity bit is transmitted and checked as logic 1. If bit 5 is a logic 0 Stick Parity is disabled.										
4		This bit is the Even Parity Select bit. When bit 3 is logic 1 and bit 4 is logic 0, an odd number of logic 1s is transmitted or checked in the data word bits and Parity bit. When bit 3 is logic 1 and bit 4 is logic 1, an even number of logic 1s is transmitted or checked.										
3		This bit is the Parity Enable bit. When bit 3 is logic 1, a Parity bit is generated (transmit data) or checked (receive data) between the last data word bit and Stop bit of the serial data. (The Parity bit is used to produce an even or odd number of 1s when the data word bits and the Parity bit are summed).										
2		This bit specifies the number of Stop bits transmitted and received in each serial character. If bit 2 is logic 0, one Stop bit is generated in the transmitted data. If bit 2 is logic 1 when a 5-bit word length is selected via bits 0 and 1, one and a half Stop bits are generated. If bit 2 is a logic 1 when either a 6-, 7- or 8-bit word length is selected, two Stop bits are generated. The Receiver checks the first Stop-bit only, regardless of the number of Stop bits selected.										
1:0	R/W	These two bits specify the number of bits in each transmitted and received serial character. The encoding of bits 0 and 1 is as follows:										
		<table border="1"> <thead> <tr> <th>Value</th> <th>Character Length</th> </tr> </thead> <tbody> <tr> <td>00</td> <td>5 Bits</td> </tr> <tr> <td>01</td> <td>6 Bits</td> </tr> <tr> <td>10</td> <td>7 Bits</td> </tr> <tr> <td>11</td> <td>8 Bits</td> </tr> </tbody> </table>	Value	Character Length	00	5 Bits	01	6 Bits	10	7 Bits	11	8 Bits
Value	Character Length											
00	5 Bits											
01	6 Bits											
10	7 Bits											
11	8 Bits											

Programmable Baud Generator

The UART contains a programmable Baud Generator that is capable of taking any clock input from DC to 8.0MHz and dividing it by any divisor from 2 to $2^{16}-1$. 5.185 MHz(70MHz CPU Clock) is the highest input clock frequency recommended when the divisor=1. The output frequency of the Baud Generator is 16 x the Baud [divisor # = (frequency input) / (baud rate x 16)]. Two 8-bit latches store the divisor in a 16-bit binary format. These Divisor Latches must be loaded during initialization to ensure proper operation of the Baud Generator. Upon loading either of the Divisor Latches, a 16-bit Baud counter is immediately loaded.

Baud rate table below provides decimal divisors to use with a crystal frequency of 3.6864MHz. For baud rates of 38400 and below, the error obtained is minimal. The accuracy of the desired baud rate is dependent on the crystal frequency chosen. Using a divisor of zero is not recommended.

Desired Baud Rate	Decimal Divisor (Used to generate 16 x Clock)	Percent Error Difference Between Desired and Actual
50	4608	-
110	2094	0.026
300	768	-
1200	192	-
2400	96	-
4800	48	-
9600	24	-
19200	12	-
38400	6	-
57600	4	-
115200	2	-

Table 10-10 Baud Rate with Decimal Divisor at 3.6864MHz Crystal Frequency

10.8.2.5 MCR

This register controls the interface with the MODEM or data set (or a peripheral device emulating a MODEM).

UxBase+0x10

7	6	5	4	3	2	1	0
0	0	0	LOOP	-	-	RTS	DTR

Bits	Type	Function
7:5	R	These bits are permanently set to logic 0
4		This bit provides a local loop back feature for diagnostic testing of the UART. When bit 4 is set to logic 1, the following occur: the transmitter Serial Output (SOUT) is set to the Marking (logic 1) state; the receiver Serial Input (SIN) is disconnected; the output of the Transmitter Shift Register is "looped back" into the Receiver Shift Register input; the four MODEM Control inputs (NCTS, NDSR, NDCD and NRI) are disconnected; and the two MODEM Control outputs (NDTR and NRTS) are internally connected to the four MODEM Control inputs, and the MODEM Control output pins are forced to their inactive state (HIGH). On the diagnostic mode, data that is transmitted is immediately received. This feature allows the processor to verify the transmit- and received-data paths of the UART. In the diagnostic mode, the receiver and transmitter interrupts are fully operational. Their sources are external to the part. The MODEM Control interrupts are also operational, but the interrupts sources are now the lower four bits of the MODEM Control Register instead of the four MODEM Control inputs. The interrupts are still controlled by the Interrupt Enable Register.
3:2	-	Reserved
1		This bit controls the Request to Send (nURTS) output. Bit 1 affects the NRTS output in a manner identical to that described above for bit 0.
0	R/W	This bit controls the Data Terminal Ready (nUDTR) output. When bit is set to logic 1, the NDTR output is forced to logic 0. When bit 0 is reset to logic 0, the NDTR output is forced to logic 1. Note: The NDTR output of the UART may be applied to an EIA inverting line driver (such as the DS1488) to obtain the proper polarity input at the succeeding MODEM or data set.

10.8.2.6 LSR

This register provides status information to the CPU concerning the data transfer.

UxBase+0x14

7	6	5	4	3	2	1	0
FIFO ERR	TEMT	THRE	BI	FE	PE	OE	DR

Bits	Type	Function
7	R	In the 16C450 mode this is always 0. In the FIFO mode LSR7 is set when there is at least one parity error, framing error or break indication in the FIFO. LSR7 is cleared when the CPU reads the LSR, if there are no subsequent errors in the FIFO.
6	R	This bit is the Transmitter Empty (TEMT) indicator. Bit 6 is set to a logic 1 whenever the Transmitter Holding Register (THR) and the Transmitter Shift Register (TSR) are both empty. It is reset to logic 0 whenever either the THR or TSR contains a data character. In the FIFO mode this bit is set to one whenever the transmitter FIFO and register are both empty.
5	R	This bit is the Transmitter Holding Register Empty (THRE) indicator. Bit 5 indicates that the UART is ready to accept a new character for transmission. In addition, this bit causes the UART to issue an interrupt to the CPU when the Transmit Holding Register Empty Interrupt enable is set HIGH. The THRE bit is set to a logic 1 when a character is transferred from the Transmitter Holding Register into the Transmitter Shift Register. The bit is reset to logic 0 concurrently with the loading of the Transmitter Holding Register. In the FIFO mode this bit is set when the XMIT FIFO is empty; it is cleared when at least 1 byte is written to the XMIT FIFO.
4	R	This bit is the Break Interrupt (BI) indicator. Bit 4 is set to logic 1 whenever the received data input is held in the Spacing (logic 0) state for longer than a full word transmission time (that is, the total time of Start bit + data bits + Parity + Stop bits). The BI indicator is reset whenever the CPU reads the contents of the Line Status Register. In the FIFO mode this error is associated with the particular character in the FIFO it applies to. This error is revealed to the CPU when its associated character is at the top of the FIFO. When break occurs, only one zero character is loaded into the FIFO. The next character transfer is enabled after SIN goes

		to the marking state and receives the next valid start bit.
		Note: Bits 1--4 are the error conditions that produce a Receiver Line Status interrupt whenever any of the corresponding conditions are detected and the interrupt is enabled.
3	R	This bit is the Framing Error (FE) indicator. Bit 3 indicates that the received character did not have a valid stop bit. Bit 3 is set to logic 1 whenever the Stop bit following the last data bit or parity bit is detected as a logic 0 bit (Spacing level). The FE indicator is reset whenever the CPU reads the contents of the Line Status Register. In the FIFO mode this error is associated with the particular character in the FIFO it applies to. This error is revealed to the CPU when its associated character is at the top of the FIFO. The UART will try to re-synchronize after a framing error. To do this it assumes that the framing error was due to the next start bit, so it samples this "start" bit twice and then takes in the "data".
2	R	This bit is the Parity Error (PE) indicator. Bit 2 indicates that the received data character does not have the correct even or odd parity, as selected by the even-parity-select bit. The PE bit is set to logic 1 upon detection of a parity error and is reset to logic 0 whenever the CPU reads the contents of the Line Status Register. In the FIFO mode, this error is associated with the particular character in the FIFO it applies to. This error is revealed to the CPU when its associated character is at the top of the FIFO.
1	R	This bit is the Overrun Error (OE) indicator. Bit 1 indicates that data in the Receiver Buffer Register was not read by the CPU before the next character was transferred into the Receiver Buffer Register, thereby destroying the previous character. The OE indicator is set to logic 1 upon detection of an overrun condition and reset whenever the CPU reads the contents of the Line Status Register. If the FIFO mode data continues to fill the FIFO beyond the trigger level, an overrun error will occur only after the FIFO is full and the next character has been completely received in the shift register. OE is indicated to the CPU as soon as it happens. The character in the shift register is overwritten, but it is not transferred to the FIFO.
0	R	This bit is the receiver Data Ready (DR) indicator. Bit 0 is set to logic 1 whenever a complete incoming character has been received and transferred into the Receiver Buffer Register or the FIFO. Bit 0 is reset to logic 0 by reading all of the data in the Receiver Buffer Register or the FIFO.

Some bits in LSR are automatically cleared when CPU reads the LSR register, so interrupt handling routine should be written that if once reads LSR, then keep the value through entire the routine because second reading LSR returns just reset value.

10.8.2.7 MSR

This register provides the current state of the control lines from the MODEM (or peripheral device) to the CPU. In addition to this current-state information, four bits of the MODEM Status Register provide change information. These bits are set to logic 1 whenever a control input from the MODEM change state. They are reset to logic 0 whenever the CPU reads the MODEM Status Register.

UxBASE+0x18

7	6	5	4	3	2	1	0
DCD	RI	DSR	CTS	DDCD	TERI	DDSR	DCTS

Bits	Type	Function
7		This bit is the complement of the Data Carrier Detect (nUDCD) input. If bit 4 of the MCR is set to a 1, this bit is equivalent to OUT2 in the MCR.
6		This bit is the complement of the Ring Indicator (nURING) input. If bit 4 of the MCR is set to a 1, this bit is equivalent to OUT1 in the MCR.
5		This bit is the complement of the Data Set Ready (nUDSR) input. If bit 4 of the MCR is set to a 1, this bit is equivalent to DTR in the MCR.
4		This bit is the complement of the Clear to Send (nUCTS) input. If bit 4 (loop) of the MCR is set to a 1, this bit is equivalent to RTS in the MCR.
3		This bit is the Delta Data Carrier Detect (nUDCD) indicator. Bit 3 indicates that the nUDCD input to the chip has changed state since the last time it was read by the CPU. Note: Whenever bit 0, 1, 2 or 3 is set to logic 1, a MODEM Status Interrupt is generated.
2		This bit is the Trailing Edge of Ring Indicator (TERI) detector. Bit 2 indicates that the nURING input to the chip has changed from a LOW to a HIGH state.
1		This bit is the Delta Data Set Ready (nUDSR) indicator. Bit 1 indicates that the nUDSR input

		to the chip has changed state since the last time it was read by the CPU.
0	R/W	This bit is the Delta Clear to Send (nUCTS) indicator. Bit 0 indicates that the nUCTS input to the chip has changed state since the last time it was read by the CPU.

10.8.2.8 SCR

This 8-bit Read/Write Register does not control the UART in any way. It is intended as a scratchpad register to be used by the programmer to hold data temporarily.

							UxBase+0x1C
7	6	5	4	3	2	1	0
DATA							
<hr/>							
Bits	Type	Function					
7:0	R/W	Temporary data storage					

10.8.2.9 UartEn

							UxBase+0x30
							0
				SIR Loop Back <i>Uart1 only</i>	Full Duplex Force <i>Uart1 only</i>	SIREN <i>Uart1 only</i>	UARTEN
<hr/>							
Bits	Type	Function					
7:4	-	Reserved					
3	R/W	SIR Loop-back Test (<i>Uart1 only</i>) 0 = SIR Loop-back Test disable 1 = SIR Loop-back Test enable.					
2	R/W	SIR Full-duplex Force (<i>Uart1 only</i>) 0 = Half Duplex. 1 = Full Duplex.					
1	R/W	SIR Enable (<i>Uart1 only</i>) 0 = SIR Mode disable 1 = SIR Mode enable (If you use SIR function, you must set this bit with UART En bit at the same time).					
0	R/W	UART Enable. 0 = UART disable (Power-Down), UART Clock stop. 1 = UART enable.					

10.8.3 FIFO Interrupt Mode Operation

When the RCVR FIFO and receiver interrupts are enabled (FCR 0 = 1, IER 0 = 1) RCVR interrupts occur as follows:

1. The received data available interrupt will be issued to the CPU when the FIFO has reached its programmed trigger level. It will be cleared as soon as the FIFO drops below its programmed trigger level.
2. The IIR receive data available indication also occurs when the FIFO trigger level is reached, and like the interrupt, it is cleared when the FIFO drops below the trigger level.
3. The receiver line status interrupt (IIR-06), as before, has higher priority than the received data available (IIR-04) interrupt.
4. The data ready bit (LSR 0) is set as soon as a character is transferred from the shift register to the RCVR FIFO. It is reset when the FIFO is empty.
- 5.

When RCVR FIFO and receiver interrupts are enabled, RCVR FIFO time-out interrupts occurs as follows:

1. A FIFO time-out interrupt occurs if the following conditions exist: at least one character is in the FIFO
- the most recent serial character received was longer than four continuous character times ago

(if two stop bits are programmed, the second one is included in this time delay)

- the most recent CPU read of the FIFO was longer than four continuous character times ago

This will cause a maximum character received to interrupt issued delay of 160 ms at 300 baud with a 12-bit character.

2. Character times are calculated by using the RCLK input, which is the internal signal of UART for a clock signal (this makes the delay proportional to the baud rate).
3. When a time-out interrupt has occurred, it is cleared and the timer is reset when the CPU reads one character from the RCVR FIFO.
4. When a time-out interrupt has not occurred the time-out timer is reset after a new character is received or after the CPU reads the RCVR FIFO.

When the XMIT FIFO and transmitter interrupts are enabled (FCR 0 = 1, IER 1 = 1), XMIT interrupts occurs as follows:

1. 1 The transmitter holding register interrupt (O2) occurs when the XMIT FIFO is empty. It is cleared as soon as the transmitter holding register is written to (1 to 16 characters may be written to the XMIT FIFO while servicing this interrupt) or the IIR is read.
2. 2 The transmitter FIFO empty indications will be delayed 1 character time minus the last stop bit time whenever the following occurs: THRE = 1 and there has not been at least two bytes at the same time in the transmit FIFO since the last THRE = 1. The first transmitter interrupt affect changing FCR0 will be immediate if it is enabled.

Character time-out and RCVR FIFO trigger level interrupts have the same priority as the current received data available interrupt; XMIT FIFO empty has the same priority as the current transmitter holding register empty interrupt.

10.9 Watchdog Timer

The watchdog timer (WDT) has a one-channel for monitoring system operations. If a system becomes uncontrolled and the timer counter overflows without being rewritten correctly by the CPU, a reset signal is output to PMU.

When this watchdog function is not needed, the WDT can be used as an interval timer. In the interval timer operation, an interval timer interrupt is generated at each counter overflow.

FEATURES

- Watchdog timer mode and interval timer mode
- Interrupt signal INT_WDT to interrupt controller in the watchdog timer mode & interval timer mode
- Output signal MNRESET to PMU (Power Management Unit)
- Eight counter clock sources
- Selection whether to reset the chip internally or not
- Reset signal type: manual reset

10.9.1 Watchdog Timer Operation

10.9.1.1 The Watchdog Timer Mode

To use the WDT as a watchdog timer, set the MODESEL and TMEN bits of the WDTCTRL to 1. Software must prevent WDTCNT overflow by rewriting the WDTCNT value (normally by writing 0x00) before overflow occurs. If the WDTCNT fails to be rewritten and overflow due to a system crash or the like, INT_WDT signal and PORESET/MNRESET signal are output. The INT_WDT signal is not output if INTREN is disabled (INTREN = 0).

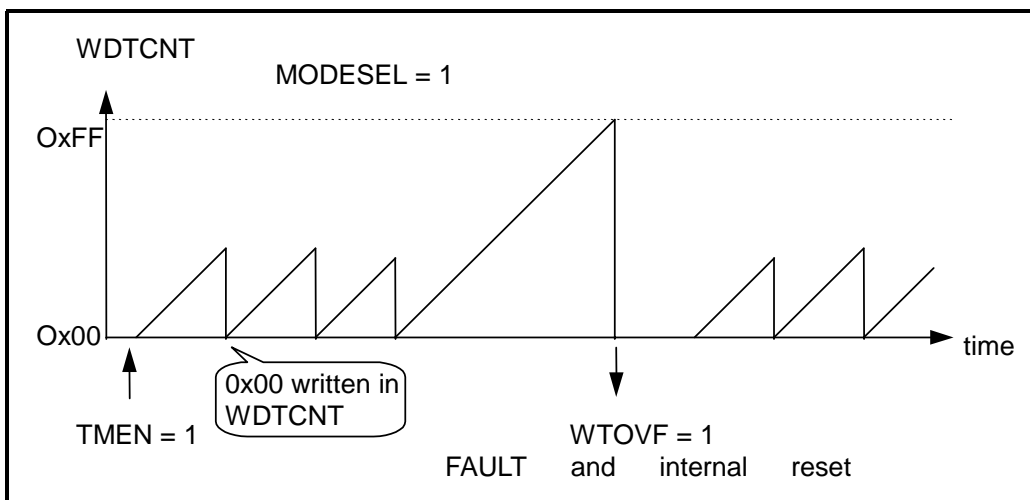

Figure 10-7 WDT Operation in the Watchdog Timer mode

If the RSTEN bit in the WDTCTRL is set to 1, a signal to reset the chip will be generated internally when WDTCNT overflows.

10.9.1.2 The Interval Timer Mode

To use the WDT as an interval timer, clear MODESEL in WDTCTRL to 0 and set TMEN to 1. A watchdog timer interrupt (INT_WDT) is generated each time the timer counter overflows. This function can be used to generate interval timer interrupts at regular intervals.

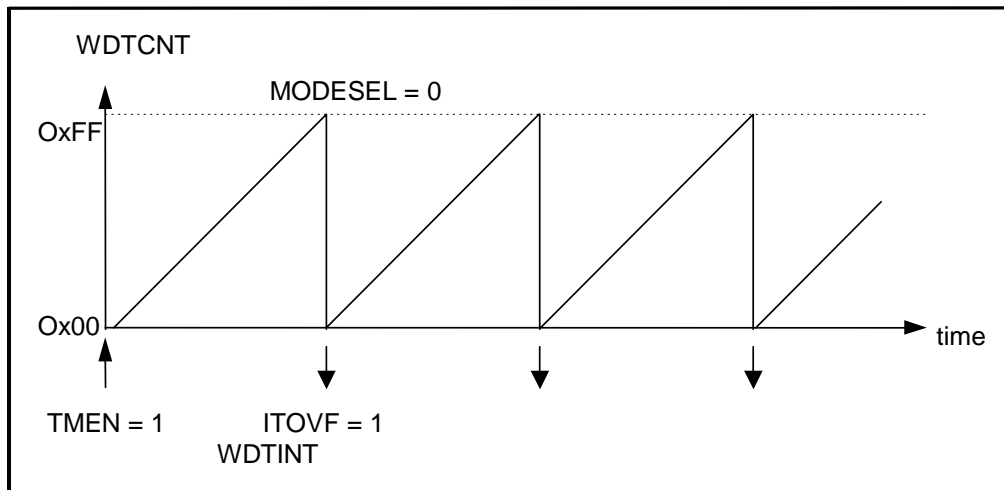

Figure 10-8 WDT Operation in the Interval Timer mode

10.9.1.3 Timing of setting the overflow flag

In the interval timer mode when the WDCNT overflows, the ITOVF flag is set to 1 and an watchdog timer interrupt (INT_WDT) is requested.

In the watchdog timer mode when the WDCNT overflows, the WTOVF bit of the WDTSTAT is set to 1 and a WDTOUT signal is output. When RSTEN bit is set to 1, WDCNT overflow enables an internal reset signal to be generated for the entire chip.

10.9.1.4 Timing of clearing the overflow flag

When the WDT Status Register (WDTSTAT) is read, the overflow flag is cleared.

10.9.2 Registers

Address	Name	Width	Default	Description
0x8002.B000	WDTCTRL	8	0x0	Timer/Reset Control
0x8002.B004	WDTSTAT	2	0x0	Reset Status
0x8002.B008	WDCNT	8		Timer Counter

Table 10-11 Watchdog Timer Register Summary

10.9.2.1 WDT Control Register (WDTCTRL)

7	6	5	4	3	2	1	0
INTREN	MODESEL	TMEN	RSTEN	RSTSEL	CLK SOURCE SEL		
0x8002.B000							
Bits	Type	Function					
7	R/W	Enable or disable the interrupt request. 0 = disable 1 = enable					
6	R/W	Select whether to use the WDT as a watchdog timer or interval timer. 0 = interval timer mode 1 = watchdog timer mode					
5	R/W	Enable or disable the timer. 0 = disable 1 = enable					
4	R/W	Select whether to reset the chip internally or not if the TCNT overflows in the watchdog timer mode. 0 = disable					

		1 = enable
3	R/W	Select the type of generated internal reset if the TCNT overflows in the watchdog timer mode. 1 = manual reset enable
2:0	R/W	The WDT has a clock generator which products eight counter clock sources. The clock signals are obtained by dividing the frequency of the system clock (B_CLK).

VALUE
CLOCK SOURCE (SYSTEM CLOCK = 40 MHz)
OVERFLOW INTERVAL

- 000
The system clock is divided by 2
12.8 us
- 001
The system clock is divided by 8
51.2 us
- 010
The system clock is divided by 32
204.8 us
- 011
The system clock is divided by 64
409.6 us
- 100
The system clock is divided by 256
1.64 ms
- 101
The system clock is divided by 512
3.28 ms
- 110
The system clock is divided by 2048
13.11 ms
- 111
The system clock is divided by 8192
52.43 ms

10.9.2.2 WDT Status Register (WDTSTAT)

							0x8002.B004	
						1	0	
						ITOVF	WTOVF	
Bits	Type	Function						
7:2	-	Reserved						
1	R	Set when WDCNT has overflowed in the interval timer mode.						
0	R	Set when WDCNT has overflowed in the watchdog timer mode.						

10.9.2.3 WDT Counter (WDCNT)

							0x8002.B008	
7	6	5	4	3	2	1	0	
WDCNT								
Bits	Type	Function						

7:0	R	8-bit up counter. When the timer is enabled, the timer counter starts counting pulse of the selected clock source. When the value of the WDCNT changes from 0xFF-0x00(overflows), a watchdog timer overflow signal is generated in the both timer modes. The WDCNT is initialized to 0x00 by a power-reset.
-----	---	---

10.9.3 Examples of Register Setting

10.9.3.1 Interval Timer Mode

TCNT = 0x00 TRCR = 0xA0

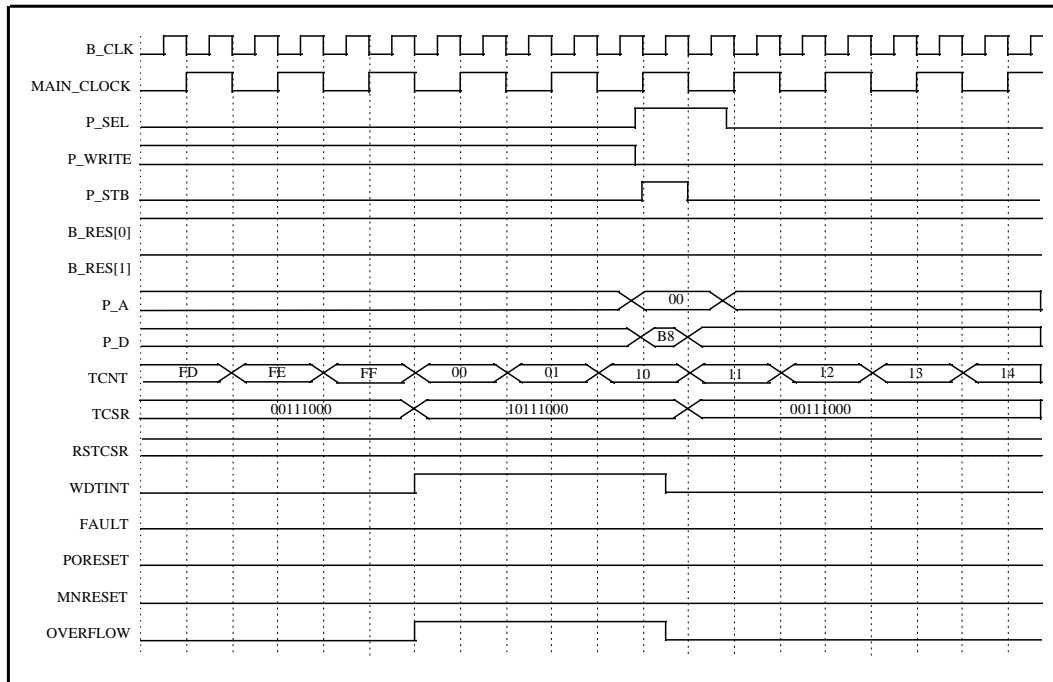

Figure 10-9 Interrupt Clear in the interval timer mode

10.9.3.2 Watchdog Timer Mode with Internal Reset Disable

TCNT = 0x00 (normally) TRCR = 0xE0

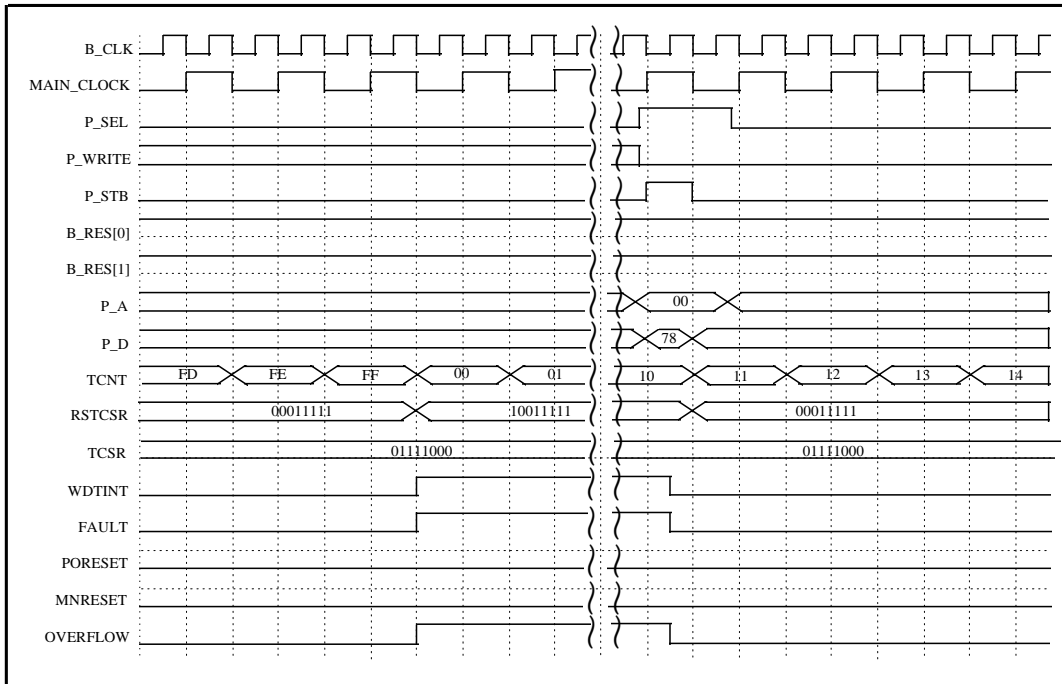

Figure 10-10 Interrupt Clear in the watchdog timer mode with reset disable

10.9.3.3 Watchdog Timer Mode with Manual Reset

TCNT = 0x00 TRCR = 0xF8

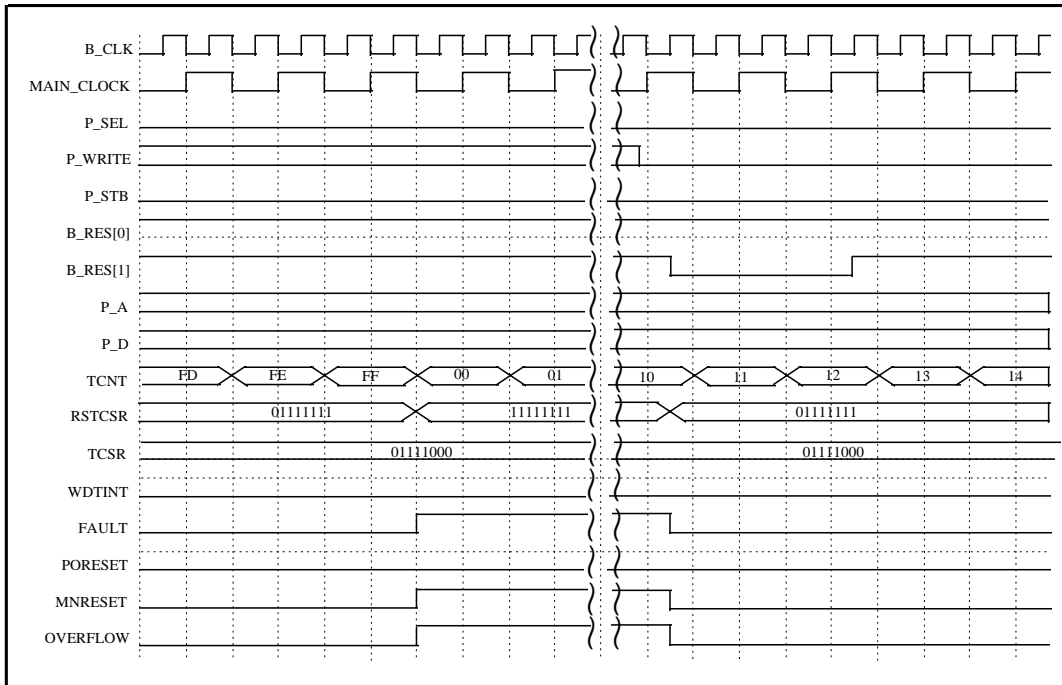

Figure 10-11 Interrupt Clear in the watchdog timer mode with manual reset

11 DEBUG AND TEST INTERFACE

11.1 Overview

The HMS30C7202 has built-in features that enable debug and test in a number of different contexts. Firstly, there are circuit structures to help with software development. Secondly, the device contains boundary scan cells for circuit board test. Finally, the device contains some special test modes that enable the generation production patterns for the device itself.

11.2 Software Development Debug and Test Interface

The ARM720T and Piccolo processors incorporated inside HMS30C7202 contain hardware extensions for advanced debugging features. These are intended to ease user development and debugging of application software, operating systems, and the hardware itself.

Full details of the debug interfaces and their programming can be found in *ARM720T Data Sheet* (ARM DDI-0087) and *Piccolo Data Sheet* (ARM DDI-0128). The MultiICE product enables the ARM720T and Piccolo macrocells to be debugged in one environment. Refer to *Guide to MultiICE* (ARM DUI-0048).

11.3 Test Access Port and Boundary-Scan

HMS30C7202 contains full boundary scan on its inputs and outputs to help with circuit board test. This supports both INTEST and EXTEST, allowing patterns to be applied serially to the HMS30C7202 when fixed in a board and for full circuit board connection respectively. The boundary-scan interface conforms to the IEEE Std. 1149.1- 1990, Standard Test Access Port and Boundary-Scan Architecture. (Please refer to this standard for an explanation of the terms used in this section and for a description of the TAP controller states.) The boundary-scan interface provides a means of testing the core of the device when it is fitted to a circuit board, and a means of driving and sampling all the external pins of the device irrespective of the core state. This latter function permits testing of both the device's electrical connections to the circuit board, and (in conjunction with other devices on the circuit board having a similar interface) testing the integrity of the circuit board connections between devices. The interface intercepts all external connections within the device, and each such "cell" is then connected together to form a serial register (the boundary scan register). The whole interface is controlled via 5 dedicated pins: **TDI**, **TMS**, **TCK**, **nTRST** and **TDO**. **Figure 11-1: Test Access Port (TAP) Controller State Transitions** shows the state transitions that occur in the TAP controller.

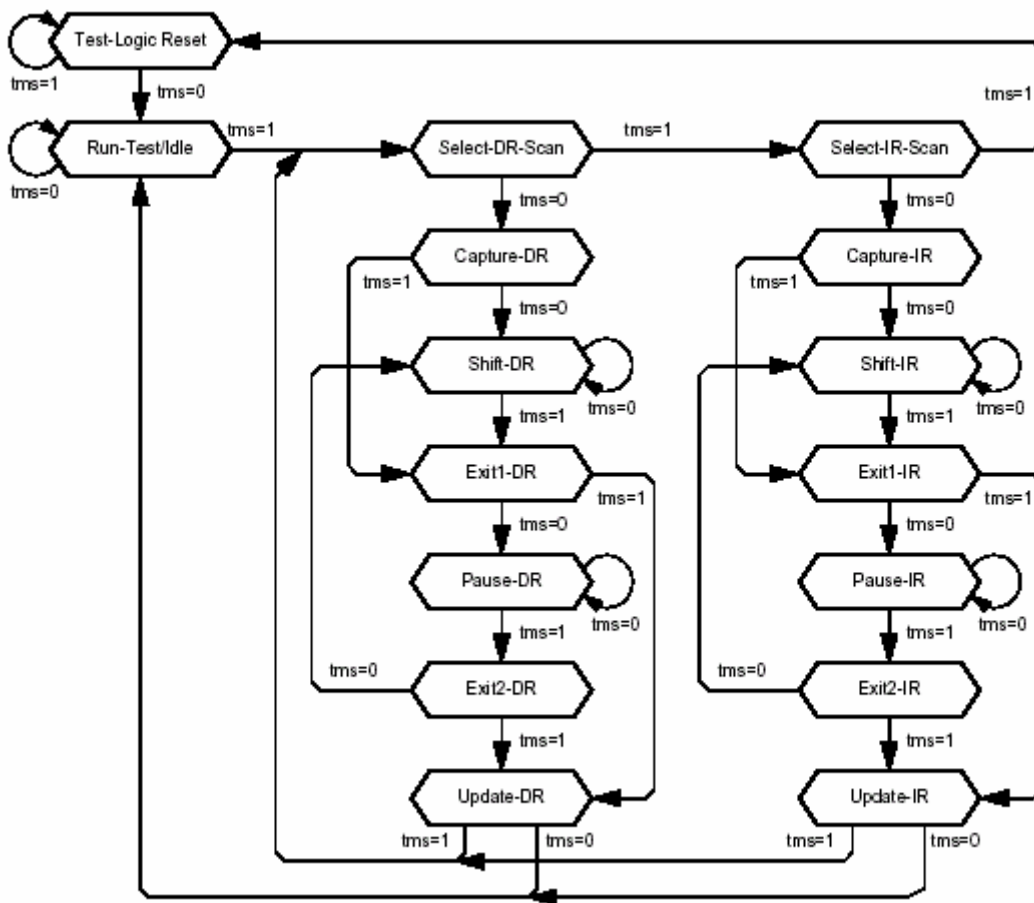

Figure 11-1: Test Access Port (TAP) Controller State Transitions

11.3.1 Reset

The boundary-scan interface includes a state-machine controller (the TAP controller).

A pulldown resistor is included in the **nTRST** pad which holds the TAP controller state machine in a safe state after power up. In order to use the boundary scan interface, **nTRST** should be driven HIGH to take the TAP state machine out of reset.

The action of reset (either a pulse or a DC level) is as follows:

- System mode is selected (i.e. the boundary scan chain does NOT intercept any of the signals passing between the pads and the core).
- IDcode mode is selected. If **TCK** is pulsed, the contents of the ID register will be clocked out of **TDO**.

Note The TAP controller inside HMS30C7202 contains a scan chip register which is reset to the value **b0011** thus selecting the boundary scan chain. If this register is programmed to any value other than **b0011**, then it must be reprogrammed with **b0011** or a reset applied before boundary scan operation can be attempted.

11.3.2 Pull up Resistors

The IEEE 1149.1 standard requires pullup resistors in the input pins. However, to ensure safe operation an internal pulldown is present in the **nTRST** pin and therefore will have to be driven HIGH when using this interface.

Pin Name	Internal Resistor
TCLK	Pullup
nTRST	Pulldown
TMS	Pullup
TDI	Pullup

11.3.3 Instruction Register

The instruction register is 4 bits in length.

There is no parity bit. The fixed value loaded into the instruction register during the CAPTURE-IR controller state is: 0001.

11.3.4 Public Instructions

The following public instructions are supported:

Instruction	Binary Code
EXTEST	0000
SAMPLE/PRELOAD	0011
CLAMP	0101
HIGHZ	0111
CLAMPZ	1001
INTEST	1100
IDCODE	1110
BYPASS	1111

In the descriptions that follow, **TDI** and **TMS** are sampled on the rising edge of **TCK** and all output transitions on **TDO** occur as a result of the falling edge of **TCK**.

EXTEST (0000)

The BS (boundary-scan) register is placed in test mode by the EXTEST instruction. The EXTEST instruction connects the BS register between **TDI** and **TDO**. When the instruction register is loaded with the EXTEST instruction, all the boundary-scan cells are placed in their test mode of operation.

In the CAPTURE-DR state, inputs from the system pins and outputs from the boundary-scan output cells to the system pins are captured by the boundary-scan cells. In the SHIFT-DR state, the previously captured test data is shifted out of the BS register via the **TDO** pin, whilst new test data is shifted in via the **TDI** pin to the BS register parallel input latch. In the UPDATE-DR state, the new test data is transferred into the BS register parallel output latch. Note that this data is applied immediately to the system logic and system pins. The first EXTEST vector should be clocked into the boundary-scan register, using the SAMPLE/PRELOAD instruction, prior to selecting EXTEST to ensure that known data is applied to the system logic.

SAMPLE/PRELOAD (0011)

The BS (boundary-scan) register is placed in normal (system) mode by the SAMPLE/PRELOAD instruction.

The SAMPLE/PRELOAD instruction connects the BS register between **TDI** and **TDO**.

When the instruction register is loaded with the SAMPLE/PRELOAD instruction, all the boundary-scan cells are placed in their normal system mode of operation.

In the CAPTURE-DR state, a snapshot of the signals at the boundary-scan cells is taken on the rising edge of **TCK**. Normal system operation is unaffected. In the SHIFT-DR state, the sampled test data is shifted out of the BS register via the **TDO** pin, whilst new data is shifted in via the **TDI** pin to preload the BS register parallel input latch. In the UPDATE-DR state, the preloaded data is transferred into the BS register parallel output latch. Note that this data is not applied to the system logic or system pins while the SAMPLE/PRELOAD

instruction is active. This instruction should be used to preload the boundary-scan register with known data prior to selecting the INTEST or EXTEST instructions.

CLAMP (0101)

The CLAMP instruction connects a 1 bit shift register (the BYPASS register) between **TDI** and **TDO**. When the CLAMP instruction is loaded into the instruction register, the state of all output signals is defined by the values previously loaded into the boundary-scan register. A guarding pattern should be pre-loaded into the boundary-scan register using the SAMPLE/PRELOAD instruction prior to selecting the CLAMP instruction. In the CAPTURE-DR state, a logic 0 is captured by the bypass register. In the SHIFT-DR state, test data is shifted into the bypass register via **TDI** and out via **TDO** after a delay of one **TCK** cycle. Note that the first bit shifted out will be a zero. The bypass register is not affected in the UPDATE-DR state.

HIGHZ (0111)

The HIGHZ instruction connects a 1 bit shift register (the BYPASS register) between **TDI** and **TDO**. When the HIGHZ instruction is loaded into the instruction register, all outputs are placed in an inactive drive state. In the CAPTURE-DR state, a logic 0 is captured by the bypass register. In the SHIFT-DR state, test data is shifted into the bypass register via **TDI** and out via **TDO** after a delay of one **TCK** cycle. Note that the first bit shifted out will be a zero. The bypass register is not affected in the UPDATE-DR state.

CLAMPZ (1001)

The CLAMPZ instruction connects a 1 bit shift register (the BYPASS register) between **TDI** and **TDO**. When the CLAMPZ instruction is loaded into the instruction register, all outputs are placed in an inactive drive state, but the data supplied to the disabled output drivers is derived from the boundary-scan cells. The purpose of this instruction is to ensure, during production testing, that each output driver can be disabled when its data input is either a 0 or a 1. A guarding pattern (specified for this device at the end of this section) should be pre-loaded into the boundary-scan register using the SAMPLE/PRELOAD instruction prior to selecting the CLAMPZ instruction. In the CAPTURE-DR state, a logic 0 is captured by the bypass register. In the SHIFT-DR state, test data is shifted into the bypass register via **TDI** and out via **TDO** after a delay of one **TCK** cycle. Note that the first bit shifted out will be a zero. The bypass register is not affected in the UPDATE-DR state.

INTEST (1100)

The BS (boundary-scan) register is placed in test mode by the INTEST instruction. The INTEST instruction connects the BS register between **TDI** and **TDO**. When the instruction register is loaded with the INTEST instruction, all the boundary-scan cells are placed in their test mode of operation. In the CAPTURE-DR state, the complement of the data supplied to the core logic from input boundary-scan cells is captured, while the true value of the data that is output from the core logic to output boundary-scan cells is captured. Note that CAPTURE-DR captures the complemented value of the input cells for testability reasons. In the SHIFT-DR state, the previously captured test data is shifted out of the BS register via the **TDO** pin, whilst new test data is shifted in via the **TDI** pin to the BS register parallel input latch. In the UPDATE-DR state, the new test data is transferred into the BS register parallel output latch. Note that this data is applied immediately to the system logic and system pins. The first INTEST vector should be clocked into the boundary-scan register, using the SAMPLE/PRELOAD instruction, prior to selecting INTEST to ensure that known data is applied to the system logic. Single-step operation is possible using the INTEST instruction.

IDCODE (1110)

The IDCODE instruction connects the device identification register (or ID register) between **TDI** and **TDO**. The ID register is a 32-bit register that allows the manufacturer, part number and version of a component to be determined through the TAP. The IDCODE returned will be that for the ARM720T core. When the instruction register is loaded with the IDCODE instruction, all the boundary-scan cells are placed in their normal (system) mode of operation. In the CAPTURE-DR state, the device identification code (specified at the end of this section) is captured by the ID register.

In the SHIFT-DR state, the previously captured device identification code is shifted out of the ID register via the **TDO** pin, whilst data is shifted in via the **TDI** pin into the ID register. In the UPDATE-DR state, the ID register is unaffected.

BYPASS (1111)

The BYPASS instruction connects a 1 bit shift register (the BYPASS register) between **TDI** and **TDO**. When the BYPASS instruction is loaded into the instruction register, all the boundary-scan cells are placed in their normal (system) mode of operation. This instruction has no effect on the system pins. In the CAPTURE-DR state, a logic 0 is captured by the bypass register. In the SHIFT-DR state, test data is shifted into the bypass

register via **TDI** and out via **TDO** after a delay of one **TCK** cycle. Note that the first bit shifted out will be a zero. The bypass register is not affected in the UPDATE-DR state.

11.3.5 Test Data Registers

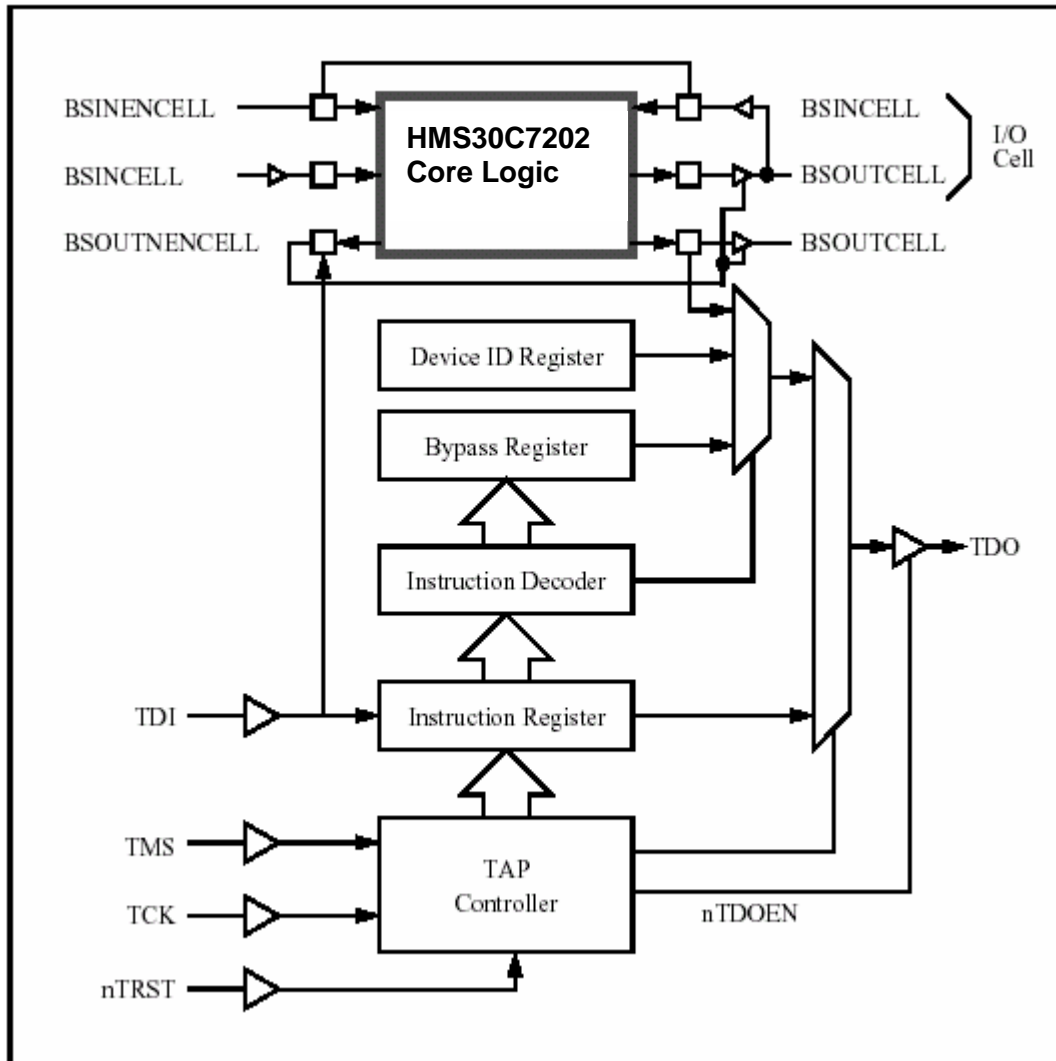

Figure 11-2: Boundary Scan Block Diagram

Bypass Register

Purpose: This is a single bit register which can be selected as the path between **TDI** and **TDO** to allow the device to be bypassed during boundary-scan testing.

Length: 1 bit

Operating Mode: When the **BYPASS** instruction is the current instruction in the instruction register, serial data is transferred from **TDI** to **TDO** in the **SHIFT-DR** state with a delay of one **TCK** cycle.

There is no parallel output from the bypass register.

A logic 0 is loaded from the parallel input of the bypass register in the **CAPTURE-DR** state.

Boundary Scan (BS) Register

Purpose: The **BS** register consists of a serially connected set of cells around the periphery of the device, at the interface between the core logic and the system input/output pads. This register can be used to isolate the

core logic from the pins and then apply tests to the core logic, or conversely to isolate the pins from the core logic and then drive or monitor the system pins. Operating modes: The BS register is selected as the register to be connected between **TDI** and **TDO** only during the SAMPLE/PRELOAD, EXTEST and INTEST instructions. Values in the BS register are used, but are not changed, during the CLAMP and CLAMPZ instructions. In the normal (system) mode of operation, straight-through connections between the core logic and pins are maintained and normal system operation is unaffected. In TEST mode (i.e. when either EXTEST or INTEST is the currently selected instruction), values can be applied to the core logic or output pins independently of the actual values on the input pins and core logic outputs respectively. On the HMS30C7202 all of the boundary scan cells include an update register and thus all of the pins can be controlled in the above manner.

Additional boundary-scan cells are interposed in the scan chain in order to control the enabling of tristateable buses. The values stored in the BS register after power-up are not defined. Similarly, the values previously clocked into the BS register are not guaranteed to be maintained across a Boundary Scan reset (from forcing **nTRST** LOW or entering the Test Logic Reset state).

Single-step Operation

HMS30C7202 is a static design and there is no minimum clock speed. It can therefore be single-stepped while the INTEST instruction is selected and the PLLs are bypassed.

This can be achieved by serializing a parallel stimulus and clocking the resulting serial vectors into the boundary-scan register. When the boundary-scan register is updated, new test stimuli are applied to the core logic inputs; the effect of these stimuli can then be observed on the core logic outputs by capturing them in the boundary-scan register.

11.3.6 Boundary Scan Interface Signals

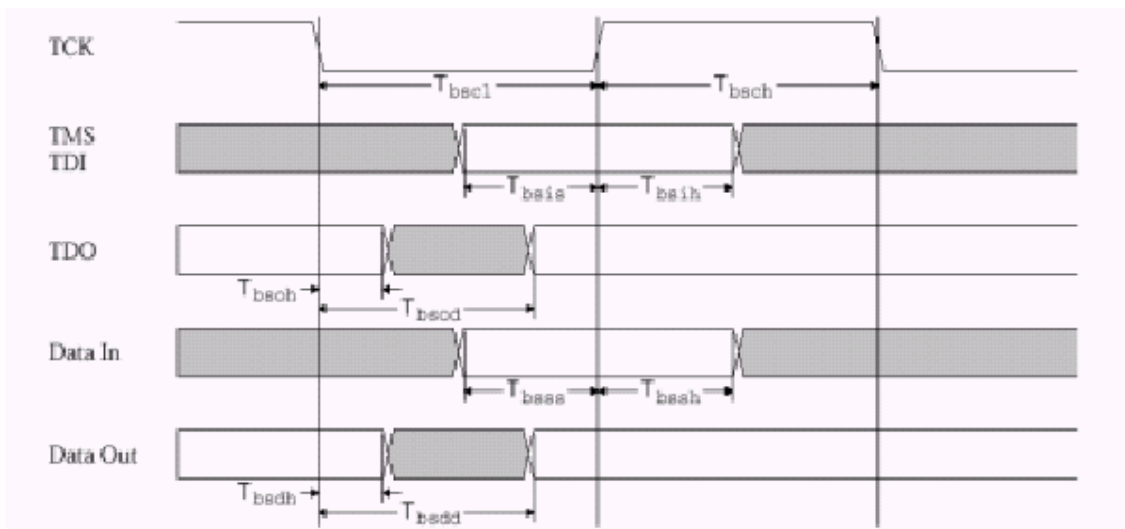
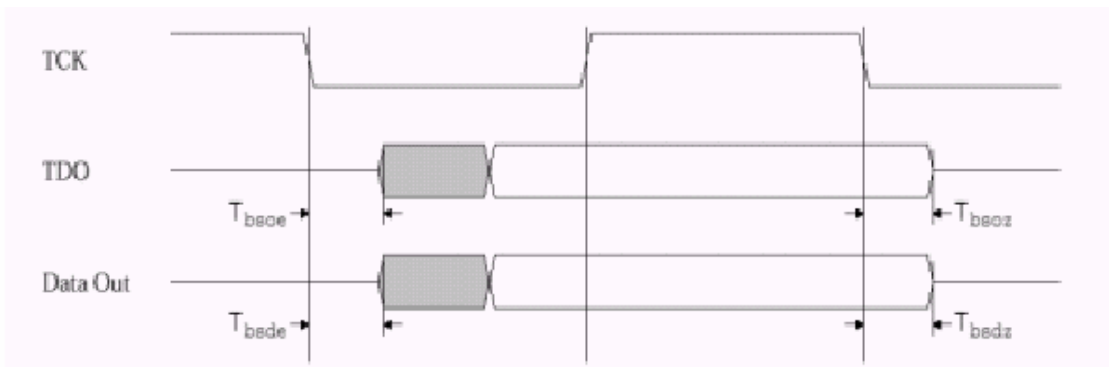
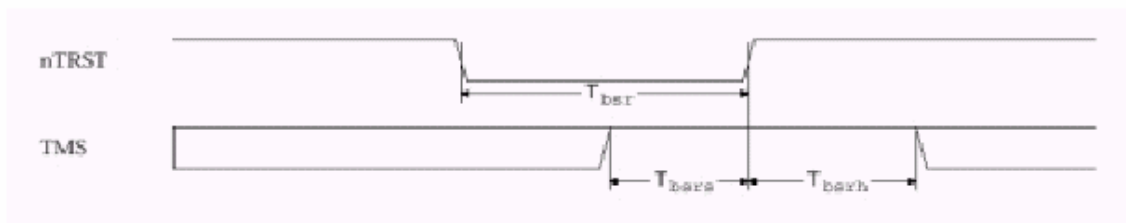

Figure 11-3: Boundary Scan General Timing

Figure 11-4: Boundary Scan Tristate Timing

Figure 11-5: Boundary Scan Reset Timing

Symbol	Parameter	Min	Max
Tbscl	TCK low period	50	-
Tbsch	TCK high period	50	-
Tbsis	TMS, TDI setup to TCKr	0	-
Tbsih	TMS, TDI hold from TCKr	2	-
Tbsoh	TDO output hold from TCKf	3	-
Tbsod	TDO output delay from TCKf	-	20
Tbsss	Test mode Data in setup to TCKr	2	-
Tbssh	Test mode Data in hold from TCKf	5	-
Tbsdh	Test mode Data out hold from TCKf	3	-
Tbsdd	Test mode Data out delay from TCKf	-	20
Tbsoe	TDO output enable delay from TCKf	2	15
Tbsoz	Test mode Data enable delay from TCKf	2	15
Tbsde	TDO output disable delay from TCKf	2	15
Tbsdz	Test mode Data disable delay from TCKf	2	15
Tbsr	NTRST minimum pulse width	25	-
Tbsrs	TMS setup to nTRSTr	20	-
Tbsrh	TMS hold from nTRSTr	20	-

The AC parameters are based on simulation results using 0.0pf circuit signal loads. Delays should be calculated using manufacturers output derating values for the actual circuit capacitance loading.

The correspondence between boundary-scan cells and system pins, system direction controls and system output enables is shown below. The cells are listed in the order in which they are connected in the boundary-scan register, starting with the cell closest to TDI. All outputs are three-state outputs. All boundary-scan register cells at input pins can apply tests to the on-chip system logic.

EXTEST/CLAMP guard values specified in the table below should be clocked into the boundary-scan register (using the SAMPLE/PRELOAD instruction) before the EXTEST, CLAMP or CLAMPZ instructions are selected to ensure that known data is applied to the system logic during the test. The INTEST guard values shown in the table below should be clocked into the boundary-scan register (using the SAMPLE/PRELOAD instruction) before the INTEST instruction is selected to ensure that all outputs are disabled. An asterisk in the guard

value column indicates that any value can be submitted (as test requires), but ones and zeros should always be placed as shown.

Num	PAD Cell Name	PIN	TYPE	Output Enable BS Cell	Guard Value	
1	uLD4	LD[4]	OUT	-	0	*
2	uLD3	LD[3]	IN	-	*	*
3	uLD3	LD[3]	OUT	-	*	*
4	uLD3	-	OUTEN	LDPADOutEn[3]	1	*
5	uLD2	LD[2]	IN	-	*	*
6	uLD2	LD[2]	OUT	-	*	*
7	uLD2	-	OUTEN	LDPADOutEn[2]	1	*
8	uLD1	LD[1]	IN	-	*	*
9	uLD1	LD[1]	OUT	-	*	*
10	uLD1	-	OUTEN	LDPADOutEn[1]	1	*
11	uLD0	LD[0]	IN	-	*	*
12	uLD0	LD[0]	OUT	-	*	*
13	uLD0	-	OUTEN	LDPADOutEn[0]	1	*
14	uKSCANO0	KSCANO[0]	IN	-	*	*
15	uKSCANO0	KSCANO[0]	OUT	-	*	*
16	uKSCANO0	-	OUTEN	MuxPORTAOutEn[0]	1	*
17	uKSCANO1	KSCANO[1]	IN	-	*	*
18	uKSCANO1	KSCANO[1]	OUT	-	*	*
19	uKSCANO1	-	OUTEN	MuxPORTAOutEn[1]	1	*
20	uKSCANO2	KSCANO[2]	IN	-	*	*
21	uKSCANO2	KSCANO[2]	OUT	-	*	*
22	uKSCANO2	-	OUTEN	MuxPORTAOutEn[2]	1	*
23	uKSCANO3	KSCANO[3]	IN	-	*	*
24	uKSCANO3	KSCANO[3]	OUT	-	*	*
25	uKSCANO3	-	OUTEN	MuxPORTAOutEn[3]	1	*
26	uKSCANO4	KSCANO[4]	IN	-	*	*
27	uKSCANO4	KSCANO[4]	OUT	-	*	*
28	uKSCANO4	-	OUTEN	MuxPORTAOutEn[4]	1	*
29	uKSCANO5	KSCANO[5]	IN	-	*	*
30	uKSCANO5	KSCANO[5]	OUT	-	*	*
31	uKSCANO5	-	OUTEN	MuxPORTAOutEn[5]	1	*
32	uKSCANO6	KSCANO[6]	IN	-	*	*
33	uKSCANO6	KSCANO[6]	OUT	-	*	*
34	uKSCANO6	-	OUTEN	MuxPORTAOutEn[6]	1	*
35	uKSCANO7	KSCANO[7]	IN	-	*	*
36	uKSCANO7	KSCANO[7]	OUT	-	*	*
37	uKSCANO7	-	OUTEN	MuxPORTAOutEn[7]	1	*
38	uKSCANI0	KSCANI[0]	IN	-	*	*
39	uKSCANI0	KSCANI[0]	OUT	-	*	*
40	uKSCANI0	-	OUTEN	MuxPORTAOutEn[8]	1	*
41	uKSCANI1	KSCANI[1]	IN	-	*	*
42	uKSCANI1	KSCANI[1]	OUT	-	*	*
43	uKSCANI1	-	OUTEN	MuxPORTAOutEn[9]	1	*
44	uKSCANI2	KSCANI[2]	IN	-	*	*
45	uKSCANI2	KSCANI[2]	OUT	-	*	*
46	uKSCANI2	-	OUTEN	MuxPORTAOutEn[10]	1	*
47	uKSCANI3	KSCANI[3]	IN	-	*	*
48	uKSCANI3	KSCANI[3]	OUT	-	*	*
49	uKSCANI3	-	OUTEN	MuxPORTAOutEn[11]	1	*
50	uKSCANI4	KSCANI[4]	IN	-	*	*
51	uKSCANI4	KSCANI[4]	OUT	-	*	*
52	uKSCANI4	-	OUTEN	MuxPORTAOutEn[12]	1	*
53	uKSCANI5	KSCANI[5]	IN	-	*	*
54	uKSCANI5	KSCANI[5]	OUT	-	*	*

55	uKSCANI5	-	OUTEN	MuxPORTAOutEn[13]	1	*
56	uKSCANI6	KSCANI[6]	IN	-	*	*
57	uKSCANI6	KSCANI[6]	OUT	-	*	*
58	uKSCANI6	-	OUTEN	MuxPORTAOutEn[14]	1	*
59	uKSCANI7	KSCANI[7]	IN	-	*	*
60	uKSCANI7	KSCANI[7]	OUT	-	*	*
61	uKSCANI7	-	OUTEN	MuxPORTAOutEn[15]	1	*
62	uATSXP	ATSXP	IN	-	*	*
63	uATSXP	ATSXP	OUT	-	*	*
64	uATSXP	-	OUTEN	ATSXPEn	1	*
65	uATSXN	ATSXN	OUT	-	0	*
66	uATSXN	-	OUTEN	ATSXNEn	1	*
67	uATSYP	ATSYP	IN	-	*	*
68	uATSYP	ATSYP	OUT	-	*	*
69	uATSYP	-	OUTEN	ATSYPEn	1	*
70	uATSYN	ATSYN	IN	-	*	*
71	uATSYN	ATSYN	OUT	-	*	*
72	uATSYN	-	OUTEN	ATSYNEn	1	*
73	unPMWAKEUP	nPMWAKEUP	IN	-	*	0
74	unPOR	nPOR	IN	-	*	0
75	unRESET	nRESET	IN	-	*	*
76	unRESET	nRESET	OUT	-	*	*
77	unRESET	-	OUTEN	nRESETEn	1	*
78	uPMADAPOK	PMADAPOK	IN	-	*	0
79	uPMBATOK	PMBATOK	IN	-	*	0
80	unPLLENABLE	nPLLENABLE	IN	-	*	0
81	unURING	nURING	IN	-	*	*
82	unURING	nURING	OUT	-	*	*
83	unURING	-	OUTEN	MuxnPORTBOutEn[0]	1	*
84	unUDTR	nUDTR	IN	-	*	*
85	unUDTR	nUDTR	OUT	-	*	*
86	unUDTR	-	OUTEN	MuxnPORTBOutEn[1]	1	*
87	unUCTS	nUCTS	IN	-	*	*
88	unUCTS	nUCTS	OUT	-	*	*
89	unUCTS	-	OUTEN	MuxnPORTBOutEn[2]	1	*
90	unURTS	nURTS	IN	-	*	*
91	unURTS	nURTS	OUT	-	*	*
92	unURTS	-	OUTEN	MuxnPORTBOutEn[3]	1	*
93	unUDSR	nUDSR	IN	-	*	*
94	unUDSR	nUDSR	OUT	-	*	*
95	unUDSR	-	OUTEN	MuxnPORTBOutEn[4]	1	*
96	unUDCD	nUDCD	IN	-	*	*
97	unUDCD	nUDCD	OUT	-	*	*
98	unUDCD	-	OUTEN	MuxnPORTBOutEn[5]	1	*
99	uUSIN0	USIN0	IN	-	*	0
100	uUSOUT0	USOUT0	OUT	-	0	*
101	uUSIN1	USIN1	iN	-	*	0
102	uUSOUT1	USOUT1	OUT	-	0	*
103	uPORTC1	CANTx[0]	IN	-	*	*
104	uPORTC1	CANTx[0]	OUT	-	*	*
105	uPORTC1	-	OUTEN	MuxnPORTCOutEn[1]	1	*
106	uPORTC2	CANRx[0]	IN	-	*	*
107	uPORTC2	CANRx[0]	OUT	-	*	*
108	uPORTC2	-	OUTEN	MuxnPORTCOutEn[2]	1	*
109	uPORTB6	PORTB[6]	IN	-	*	*
110	uPORTB6	PORTB[6]	OUT	-	*	*
111	uPORTB6	-	OUTEN	MuxnPORTBOutEn[6]	1	*
112	uPORTB7	PORTB[7]	IN	-	*	*
113	uPORTB7	PORTB[7]	OUT	-	*	*

114	uPORTB7	-	OUTEN	MuxnPORTBOutEn[7]	1	*
115	uPORTB8	PORTB[8]	IN	-	*	*
116	uPORTB8	PORTB[8]	OUT	-	*	*
117	uPORTB8	-	OUTEN	MuxnPORTBOutEn[8]	1	*
118	uPORTB9	PORTB[9]	IN	-	*	*
119	uPORTB9	PORTB[9]	OUT	-	*	*
120	uPORTB9	-	OUTEN	MuxnPORTBOutEn[9]	1	*
121	uPORTB10	PORTB[10]	IN	-	*	*
122	uPORTB10	PORTB[10]	OUT	-	*	*
123	uPORTB10	-	OUTEN	MuxnPORTBOutEn[10]	1	*
124	uPORTB11	PORTB[11]	IN	-	*	*
125	uPORTB11	PORTB[11]	OUT	-	*	*
126	uPORTB11	-	OUTEN	MuxnPORTBOutEn[11]	1	*
127	uTimerOut	TimerOut	IN	-	*	*
128	uTimerOut	TimerOut	OUT	-	*	*
129	uTimerOut	-	OUTEN	MuxnPORTCcutEn[0]	1	*
130	uPSDAT	PSDAT	IN	-	*	*
131	uPSDAT	PSDAT	OUT	-	*	*
132	uPSDAT	-	OUTEN	MuxnPORTCcutEn[3]	1	*
133	uPSCLK	PSCLK	IN	-	*	*
134	uPSCLK	PSCLK	OUT	-	*	*
135	uPSCLK	-	OUTEN	MuxnPORTCcutEn[4]	1	*
136	uPWM0	PWM[0]	IN	-	*	*
137	uPWM0	PWM[0]	OUT	-	*	*
138	uPWM0	-	OUTEN	MuxnPORTCcutEn[5]	1	*
139	uPWM1	PWM[1]	IN	-	*	*
140	uPWM1	PWM[1]	OUT	-	*	*
141	PWM1	-	OUTEN	MuxnPORTCcutEn[6]	1	*
142	uPORTE23	CANTx[1]	IN	-	*	*
143	uPORTE23	CANTx[1]	OUT	-	*	*
144	uPORTE23	-	OUTEN	-	1	*
145	uPORTE22	CANRx[1]	IN	MuxnPORTEcutEn[23]	*	*
146	uPORTE22	CANRx[1]	OUT	-	*	*
147	uPORTE22	-	OUTEN	MuxnPORTEcutEn[22]	1	*
148	uMMCCMD	MMCCMD	IN	-	*	*
149	uMMCCMD	MMCCMD	OUT	-	*	*
150	uMMCCMD	-	OUTEN	MuxnPORTEcutEn[18]	1	*
151	uMMCDAT	MMCDAT	IN	-	*	*
152	uMMCDAT	MMCDAT	OUT	-	*	*
153	uMMCDAT	-	OUTEN	MuxnPORTEcutEn[19]	1	*
154	unMMCCD	nMMCCD	IN	-	*	*
155	unMMCCD	nMMCCD	OUT	-	*	*
156	unMMCCD	-	OUTEN	MuxnPORTEcutEn[20]	1	*
157	uMMCCLK	MMCCLK	IN	-	*	*
158	uMMCCLK	MMCCLK	OUT	-	*	*
159	uMMCCLK	-	OUTEN	MuxnPORTEcutEn[21]	1	*
160	unDMAREQ	nDMAREQ	IN	-	*	*
161	unDMAREQ	nDMAREQ	OUT	-	*	*
162	unDMAREQ	-	OUTEN	MuxnPORTCOutEn[7]	1	*
163	unDMAACK	nDMAACK	IN	-	*	*
164	unDMAACK	nDMAACK	OUT	-	*	*
165	unDMAACK	-	OUTEN	MuxnPORTCOutEn[8]	1	*
166	unRCS3	nRCS[3]	IN	-	*	*
167	unRCS3	nRCS[3]	OUT	-	*	*
168	unRCS3	-	OUTEN	MuxnPORTCOutEn[10]	1	*
169	unRCS2	nRCS[2]	IN	-	*	*
170	unRCS2	nRCS[2]	OUT	-	*	*
171	unRCS2	-	OUTEN	MuxnPORTCOutEn[9]	1	*
172	unRCS1	nRCS[1]	OUT	-	0	*

173	unRCS0	nRCS[0]	OUT	-	0	*
174	uBOOTBIT1	BOOTBIT[1]	IN	-	*	0
175	uBOOTBIT0	BOOTBIT[0]	IN	-	*	0
176	unROE	nROE	OUT	-	0	*
177	uEXPRDY	EXPRDY	IN	-	*	0
178	unRWE3	nRWE[3]	IN	-	*	*
179	unRWE3	nRWE[3]	OUT	-	*	*
180	unRWE3	-	OUTEN	MuxnPORTEOutEn[17]	1	*
181	unRWE2	nRWE[2]	IN	-	*	*
182	unRWE2	nRWE[2]	OUT	-	*	*
183	unRWE2	-	OUTEN	MuxnPORTEOutEn[16]	1	*
184	unRWE1	nRWE[1]	OUT	-	0	*
185	unRWE0	nRWE[0]	OUT	-	0	*
186	uRD31	RD[31]	IN	-	*	*
187	uRD31	RD[31]	OUT	-	*	*
188	uRD31	-	OUTEN	MuxnPORTEOutEn[15]	1	*
189	uRD30	RD[30]	IN	-	*	*
190	uRD30	RD[30]	OUT	-	*	*
191	uRD30	-	OUTEN	MuxnPORTEOutEn[14]	1	*
192	uRD29	RD[29]	IN	-	*	*
193	uRD29	RD[29]	OUT	-	*	*
194	uRD29	-	OUTEN	MuxnPORTEOutEn[13]	1	*
195	uRD28	RD[28]	IN	-	*	*
196	uRD28	RD[28]	OUT	-	*	*
197	uRD28	-	OUTEN	MuxnPORTEOutEn[12]	1	*
198	uRD27	RD[27]	IN	-	*	*
199	uRD27	RD[27]	OUT	-	*	*
200	uRD27	-	OUTEN	MuxnPORTEOutEn[11]	1	*
201	uRD26	RD[26]	IN	-	*	*
202	uRD26	RD[26]	OUT	-	*	*
203	uRD26	-	OUTEN	MuxnPORTEOutEn[10]	1	*
204	uRD25	RD[25]	IN	-	*	*
205	uRD25	RD[25]	OUT	-	*	*
206	uRD25	-	OUTEN	MuxnPORTEOutEn[9]	1	*
207	uRD24	RD[24]	IN	-	*	*
208	uRD24	RD[24]	OUT	-	*	*
209	uRD24	-	OUTEN	MuxnPORTEOutEn[8]	1	*
210	uRD23	RD[23]	IN	-	*	*
211	uRD23	RD[23]	OUT	-	*	*
212	uRD23	-	OUTEN	MuxnPORTEOutEn[7]	1	*
213	uRD22	RD[22]	IN	-	*	*
214	uRD22	RD[22]	OUT	-	*	*
215	uRD22	-	OUTEN	MuxnPORTEOutEn[6]	1	*
216	uRD21	RD[21]	IN	-	*	*
217	uRD21	RD[21]	OUT	-	*	*
218	uRD21	-	OUTEN	MuxnPORTEOutEn[5]	1	*
219	uRD20	RD[20]	IN	-	*	*
220	uRD20	RD[20]	OUT	-	*	*
221	uRD20	-	OUTEN	MuxnPORTEOutEn[4]	1	*
222	uRD19	RD[19]	IN	-	*	*
223	uRD19	RD[19]	OUT	-	*	*
224	uRD19	-	OUTEN	MuxnPORTEOutEn[3]	1	*
225	uRD18	RD[18]	IN	-	*	*
226	uRD18	RD[18]	OUT	-	*	*
227	uRD18	-	OUTEN	MuxnPORTEOutEn[2]	1	*
228	uRD17	RD[17]	IN	-	*	*
239	uRD17	RD[17]	OUT	-	*	*
230	uRD17	-	OUTEN	MuxnPORTEOutEn[1]	1	*
231	uRD16	RD[16]	IN	-	*	*

232	uRD16	RD[16]	OUT	-	*	*
233	uRD16	-	OUTEN	MuxnPORTEOutEn[0]	1	*
234	uRD15	RD[15]	IN	-	*	*
235	uRD15	RD[15]	OUT	-	*	*
236	uRD15	-	OUTEN	nRDEn[1]	1	*
237	uRD14	RD[14]	IN	-	*	*
238	uRD14	RD[14]	OUT	jnRDEn[1]	*	*
239	uRD13	RD[13]	IN	-	*	*
240	uRD13	RD[13]	OUT	jnRDEn[1]	*	*
241	uRD12	RD[12]	IN	-	*	*
242	uRD12	RD[12]	OUT	jnRDEn[1]	*	*
243	uRD11	RD[11]	IN	-	*	*
244	uRD11	RD[11]	OUT	jnRDEn[1]	*	*
245	uRD10	RD[10]	IN	-	*	*
246	uRD10	RD[10]	OUT	jnRDEn[1]	*	*
247	uRD9	RD[9]	IN	-	*	*
248	uRD9	RD[9]	OUT	jnRDEn[1]	*	*
249	uRD8	RD[8]	IN	-	*	*
250	uRD8	RD[8]	OUT	jnRDEn[1]	*	*
251	uRD7	RD[7]	IN	-	*	*
252	uRD7	RD[7]	OUT	-	*	*
253	uRD7	-	OUTEN	nRDEn[0]	1	*
254	uRD6	RD[6]	IN	-	*	*
255	uRD6	RD[6]	OUT	jnRDEn[0]	*	*
256	uRD5	RD[5]	IN	-	*	*
257	uRD5	RD[5]	OUT	jnRDEn[0]	*	*
258	uRD4	RD[4]	IN	-	*	*
259	uRD4	RD[4]	OUT	jnRDEn[0]	*	*
260	uRD3	RD[3]	IN	-	*	*
261	uRD3	RD[3]	OUT	jnRDEn[0]	*	*
262	uRD2	RD[2]	IN	-	*	*
263	uRD2	RD[2]	OUT	jnRDEn[0]	*	*
264	uRD1	RD[1]	IN	-	*	*
265	uRD1	RD[1]	OUT	jnRDEn[0]	*	*
266	uRD0	RD[0]	IN	-	*	*
267	uRD0	RD[0]	OUT	jnRDEn[0]	*	*
268	uRA0	RA[0]	OUT	-	0	*
269	uRA1	RA[1]	OUT	-	0	*
270	uRA2	RA[2]	OUT	-	0	*
271	uRA3	RA[3]	OUT	-	0	*
272	uRA4	RA[4]	OUT	-	0	*
273	uRA5	RA[5]	OUT	-	0	*
274	uRA6	RA[6]	OUT	-	0	*
275	uRA7	RA[7]	OUT	-	0	*
276	uRA8	RA[8]	OUT	-	0	*
277	uRA9	RA[9]	OUT	-	0	*
278	uRA10	RA[10]	OUT	-	0	*
279	uRA11	RA[11]	OUT	-	0	*
280	uRA12	RA[12]	OUT	-	0	*
281	uRA13	RA[13]	OUT	-	0	*
282	uRA14	RA[14]	OUT	-	0	*
283	uRA15	RA[15]	OUT	-	0	*
284	uRA16	RA[16]	OUT	-	0	*
285	uRA17	RA[17]	OUT	-	0	*
286	uRA18	RA[18]	OUT	-	0	*
287	uRA19	RA[19]	OUT	-	0	*
288	uRA20	RA[20]	OUT	-	0	*
289	uRA21	RA[21]	OUT	-	0	*
290	uRA22	RA[22]	OUT	-	0	*

291	uRA23	RA[23]	OUT	-	0	*
292	uRA24	RA[24]	IN	-	*	*
293	uRA24	RA[24]	OUT	-	*	*
294	uRA24	-	OUTEN	MuxnPORTEOutEn[24]	1	*
295	uSA3	SA[3]	OUT	-	0	*
296	uSA4	SA[4]	OUT	-	0	*
297	uSA2	SA[2]	OUT	-	0	*
298	uSA5	SA[5]	OUT	-	0	*
299	uSA1	SA[1]	OUT	-	0	*
300	uSA6	SA[6]	OUT	-	0	*
301	uSA0	SA[0]	OUT	-	0	*
302	uSA7	SA[7]	OUT	-	0	*
303	uSA8	SA[8]	OUT	-	0	*
304	uSA9	SA[9]	OUT	-	0	*
305	uSA10	SA[10]	OUT	-	0	*
306	uSA11	SA[11]	OUT	-	0	*
307	uSA12	SA[12]	OUT	-	0	*
308	uSA13	SA[13]	OUT	-	0	*
309	uSA14	SA[14]	OUT	-	0	*
310	unSCS1	nSCS[1]	OUT	-	0	*
311	unSCS0	nSCS[0]	OUT	-	0	*
312	unSRAS	nSRAS	OUT	-	0	*
313	unRCAS	nSCAS	OUT	-	0	*
314	unSWE	nSWE	OUT	-	0	*
315	uSCKE1	SCKE[1]	OUT	-	0	*
316	uSCKE0	SCKE[0]	OUT	-	0	*
317	uSCLK	SCLK	IN	-	*	*
318	uSCLK	SCLK	OUT	-	*	*
319	uSCLK	-	OUTEN	1'b0	1	*
320	uSDQMU	SDQMU	OUT	-	0	*
321	uSDQML	SDQML	OUT	-	0	*
322	uSD8	SD[8]	IN	-	*	*
323	uSD8	SD[8]	OUT	jnSDEn	*	*
324	uSD7	SD[7]	IN	-	*	*
325	uSD7	SD[7]	OUT	jnSDEn	*	*
326	uSD9	SD[9]	IN	-	*	*
327	uSD9	SD[9]	OUT	jnSDEn	*	*
328	uSD6	SD[6]	IN	-	*	*
329	uSD6	SD[6]	OUT	jnSDEn	*	*
330	uSD10	SD[10]	IN	-	*	*
331	uSD10	SD[10]	OUT	jnSDEn	*	*
332	uSD5	SD[5]	IN	-	*	*
333	uSD5	SD[5]	OUT	jnSDEn	*	*
334	uSD11	SD[11]	IN	-	*	*
335	uSD11	SD[11]	OUT	jnSDEn	*	*
336	uSD4	SD[4]	IN	-	*	*
337	uSD4	SD[4]	OUT	jnSDEn	*	*
338	uSD12	SD[12]	IN	-	*	*
339	uSD12	SD[12]	OUT	jnSDEn	*	*
340	uSD3	SD[3]	IN	-	*	*
341	uSD3	SD[3]	OUT	jnSDEn	*	*
342	uSD13	SD[13]	IN	-	*	*
343	uSD13	SD[13]	OUT	jnSDEn	*	*
344	uSD2	SD[2]	IN	-	*	*
345	uSD2	SD[2]	OUT	jnSDEn	*	*
346	uSD14	SD[14]	IN	-	*	*
347	uSD14	SD[14]	OUT	jnSDEn	*	*
348	uSD1	SD[1]	IN	-	*	*
349	uSD1	SD[1]	OUT	jnSDEn	*	*

350	uSD15	SD[15]	IN	-	*	*
351	uSD15	SD[15]	OUT	-	*	*
352	usD15	-	OUTEN	nSDEn	1	*
353	uSD0	SD[0]	IN	-	*	*
354	uSD0	SD[0]	OUT	jnSDEn	*	*
355	uLLP	LLP	OUT	-	0	*
356	uLAC	LAC	OUT	-	0	*
367	uLBLEN	LBLEN	IN	-	*	*
358	uLBLEN	LBLEN	OUT	-	*	*
359	uLBLEN	-	OUTEN	MuxnPORTDOutEn[8]	1	*
360	uLCP	LCP	OUT	-	0	*
361	uLFP	LFP	OUT	-	0	*
362	uLCDEN	LCDEN	OUT	-	0	*
363	uLD15	LD[15]	IN	-	*	*
364	uLD15	LD[15]	OUT	-	*	*
365	uLD15	-	OUTEN	MuxnPORTDOutEn[7]	1	*
366	uLD14	LD[14]	IN	-	*	*
367	uLD14	LD[14]	OUT	-	*	*
368	uLD14	-	OUTEN	MuxnPORTDOutEn[6]	1	*
369	uLD13	LD[13]	IN	-	*	*
370	uLD13	LD[13]	OUT	-	*	*
371	uLD13	-	OUTEN	MuxnPORTDOutEn[5]	1	*
372	uLD12	LD[12]	IN	-	*	*
373	uLD12	LD[12]	OUT	-	*	*
374	uLD12	-	OUTEN	MuxnPORTDOutEn[4]	1	*
375	uLD11	LD[11]	IN	-	*	*
376	uLD11	LD[11]	OUT	-	*	*
377	uLD11	-	OUTEN	MuxnPORTDOutEn[3]	1	*
378	uLD10	LD[10]	IN	-	*	*
379	uLD10	LD[10]	OUT	-	*	*
380	uLD10	-	OUTEN	MuxnPORTDOutEn[2]	1	*
381	uLD9	LD[9]	IN	-	*	*
382	uLD9	LD[9]	OUT	-	*	*
383	uLD9	-	OUTEN	MuxnPORTDOutEn[1]	1	*
384	uLD8	LD[8]	IN	-	*	*
385	uLD8	LD[8]	OUT	-	*	*
386	uLD8	-	OUTEN	MuxnPORTDOutEn[0]	1	*
387	uLD7	LD[7]	OUT	-	0	*
388	uLD6	LD[6]	OUT	-	0	*
389	uLD5	LD[5]	OUT	-	0	*

11.4 Production Test Features

In order to generate test vectors suitable for use on a production tester by the chip manufacturer, some special test modes have been introduced. These modes come into operation whenever the pin nTEST is forced LOW.

Full details of these modes are available from ARM in a special Test Document on request.

12 ELECTRICAL CHARACTERISTICS

12.1 Absolute Maximum Ratings

Symbol	Parameter	Min	Max	Units
V _{DD}	Power Supply Voltage	-0.5	4.6	V
V _{IN}	DC Input Voltage	-0.3	6	V
I _{IN}	DC Input Current	-50	50	mA
T _{STG}	Storage Temperature	-65	150	°C

Note : Permanent damage can be occur if maximum ratings are exceeded.
 Device modules may not operate normally while being exposed to electrical extremes.
 Although sections of the device contain circuitry to protect against damages from high static voltages or electrical fields, take normal pre-cautions to avoid exposure to voltages higher than maximum rated voltages.

Recommended Operating Range

Symbol	Parameter	Min	Max	Units
VDD (3.3V)	DC Power Supply Voltage (3.3V) → use for I/O	3.0 2.3	3.6 2.7	V V
VDD (2.5V)	DC Power Supply Voltage (2.5V) → use for a Core	-40	85	°C
T _{OPR}	Operating Temperature (Industrial Temperature)			

12.2 DC characteristics

All characteristics are specified at $V_{DD} = 3.0$ to $3.6V$ and $V_{SS} = 0V$ over the junction temperature range of 0 to $100\text{ }^{\circ}C$.

Power Dissipation

Symbol	Parameter	Min	Max	Units
P_D	[Run Mode]			
	With LCD @70.04MHz		190	mW
P_{DWN}	Without LCD @70.04MHz		140	mW
	[Deep Sleep Mode]			
	RTC Enable	120	160	uW
	RTC Disable	30	70	uW

CMOS/TTL Compatible Pin

Symbol	Parameter	Min	Max	Conditions
V_{IL}	Low-level Input Voltage		$0.3XV_{DD}$	Guaranteed Input Low Voltage
V_{IH}	High-level Input Voltage	$0.7XV_{DD}$		Guaranteed Input High Voltage
V_{OL}	Low-level Output Voltage		0.4 V	$I_{OL} = 1\text{ mA}$ (*Group A)
			0.4 V	$I_{OL} = 2\text{ mA}$ (Group B)
			0.4 V	$I_{OL} = 4\text{ mA}$ (Group C)
V_{OH}	High-level Output Voltage	2.4 V		$I_{OH} = -1\text{ mA}$ (Group A)
		2.4 V		$I_{OH} = -2\text{ mA}$ (Group B)
		2.4 V		$I_{OH} = -4\text{ mA}$ (Group C)
I_{IL}	Input Low Current	-10 uA	10 uA	$V_{IN} = V_{SS}$
I_{IH}	Input High Current	-10 uA	10 uA	$V_{IN} = V_{DD}$
I_{OZ}	3-state Output Leakage Current	-10 uA	10 uA	$V_{PAD} = V_{SS}$ OR V_{DD}

* : It means the drive strength (Group A = 1, Group B = 2, Group C = 4)
Refer to GPIO part (page 122)

I/O Circuit Pull-up Pin

The following current values are used for I/Os with internal pull-up devices.

Symbol	Parameter	Min($V_{IN} = V_{SS}$)	Max($V_{IN} = V_{DD}$)
I_{PU}	Pull-up	-100 uA	- 4 uA

Note : The following pins are used with internal pull-up devices.
TDI, TCK, TMS, PMADAO, PMBATOK, nTEST, nPMWAKEUP

I/O Circuit Pull-down Pin

The following current values are used for I/Os with internal pull-down devices.

Symbol	Parameter	Min($V_{IN} = V_{SS}$)	Max($V_{IN} = V_{DD}$)
I_{PD}	Pull-down	4 uA	100 uA

Note : The following pins are used with internal pull-down devices.
nTRST, TESTSCAN, nPLENABLE, SCAN_EN

12.3 A/D Converter Electrical Characteristics

Symbol	Parameter	Test Condition	Min	Typ	Max	Unit
I _{dd}	Normal	aclk=8MHz * Input=AV _{ref} V fin=2KHz ramp		6.0		mA
	Power Down	aclk=8MHz		60		uA
An**	Analog Input Voltage		AVSS+0.2		AVref-0.2	V
Accuracy	Resolution				10	Bits
INL	Integral Non-linearity	aclk=8MHz Input=0 - AV _{ref} V fin=2KHz ramp		±2.0		LSB
DNL	Differential Non-linearity	aclk=8MHz Input=0 - AV _{ref} V fin=2KHz ramp		±1.0		LSB
SNR	Signal-to-Noise Ratio	F _{sample} = 500Ksps fin = 2KHz	51	54		dB
SNDR	Signal-to-Noise Distortion Ratio		49	52		dB
aclk			2	4	8	MHz
t _c	Conversion Time	t _c = [aclk/16] ⁻¹	2	4	8	us
AV _{ref} ***	Analog Reference Voltage				AVDD	V
T _{cal}	Power-up Time	Calibration Time		22		ms
THD	Total Harmonic Distortion		51	54		dB
AVDD	Analog Power		3.0	3.3	3.6	V
DVDD	Digital Power		3.0	3.3	3.6	V
fin	Analog Input Frequency			5		KHz

(For Test, Analog Input Freq. = 2KHz, aclk=8MHz, AVDD=DVDD=AV_{ref}=3.3V, Temperature=25°C)

aclk : To determine electrical characteristic of ADC, used 8MHz clock as aclk.
but for 7202 ADC, used 3.6864MHz for aclk.

an* : Analog input is sample and hold with 500Ω resistor and 300 fF capacitor in series and connected with gate of CMOS transistor.

So, in normal, input resistance of an analog input pin has a couple of Mega Ohms.

AVref** : The equivalent impedance of AVREF is about 5kΩ of resistance to GND.

12.4 D/A Converter Electrical Characteristics

Symbol	Parameter	Test Condition	Min	Typ	Max	Unit
I _{dd}	Normal	f _{CLK} =50KHz	3.6	4.1	4.6	mA
	Power Down	TBD				uA
Accuracy	Resolution			8		Bits
INL	Integral Non-linearity	DC	-0.6		+0.6	LSB
DNL	Differential Non-linearity	DC	-0.2		+0.2	LSB
SNR	Signal-to-Noise Ratio	f _{con} =50KHz Temperature=25°C	47.5	47.7	47.8	dB
SNDR	Signal-to-Noise Distortion Ratio		47.1	47.4	47.7	dB
THD	Total Harmonic Distortion		57.5	61.8	65.9	dB
f _{con}	Conversion Speed			50		KHz
tr/tf	rise/fall time	with ± 10% error		0.4		us
V _{out(p-p)}	Output Voltage Range		1.025		2.675	V
t _d	Output Delay Time			1.4		Us

The current drive capability is about 500uA on output of DAC.

Typical load is about 10kΩ of resistance and 10pF of capacitance on output of DAC.

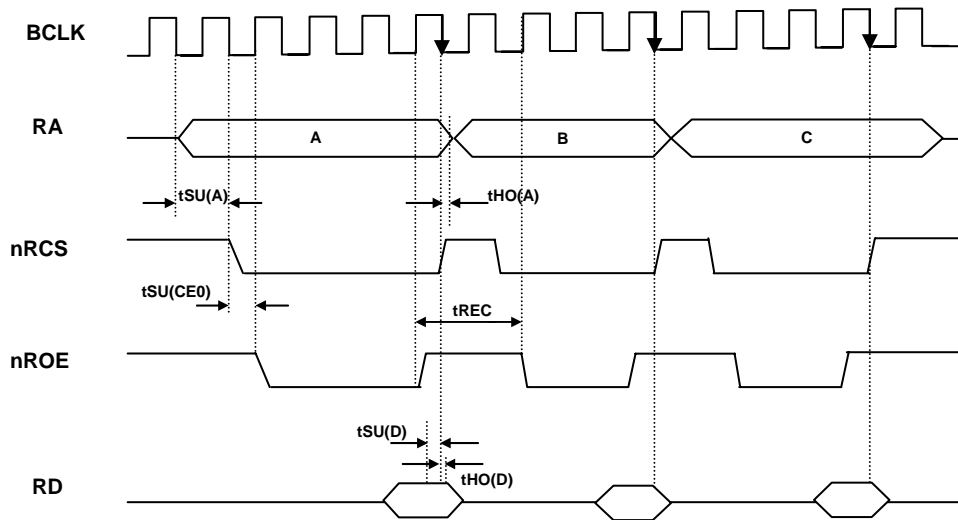
12.5 AC Characteristics
12.5.1 Static Memory Interface
12.5.1.1 READ Access Timing (Single Mode)

Symbol	Parameter	Min	Max	Unit
tSU(A)	Address to nRCS falling-edge setup time	25		ns
tHO(A)	nROE rising-edge to Address hold time	0		
tSU(CE0)	nRCS falling-edge to nROE falling-edge setup time	13		
tHO(CE0)	nROE rising-edge to nRCS rising-edge setup time	-13		
tHO(CE1)	nROE or nRWE rising-edge to nRCS falling-edge hold time	15		
tSU(CE1)	nRCS rising-edge to nROE or nRWE falling-edge setup time	25		
tREC	nROE negate to start of next cycle	50		
tSU(D)	Data setup time before latch	5		
tHO(D)	Data hold time after latch	0		

Timing values for read access in single mode data transfer

 Memory Configuration Register Setting = **0x060**

	11	10	9	8	7	6	5	4	3	2	1	0
	0	0	0	0	0	1	1	0	0	0	0	0

12.5.1.2 READ Access Timing (Burst Mode)

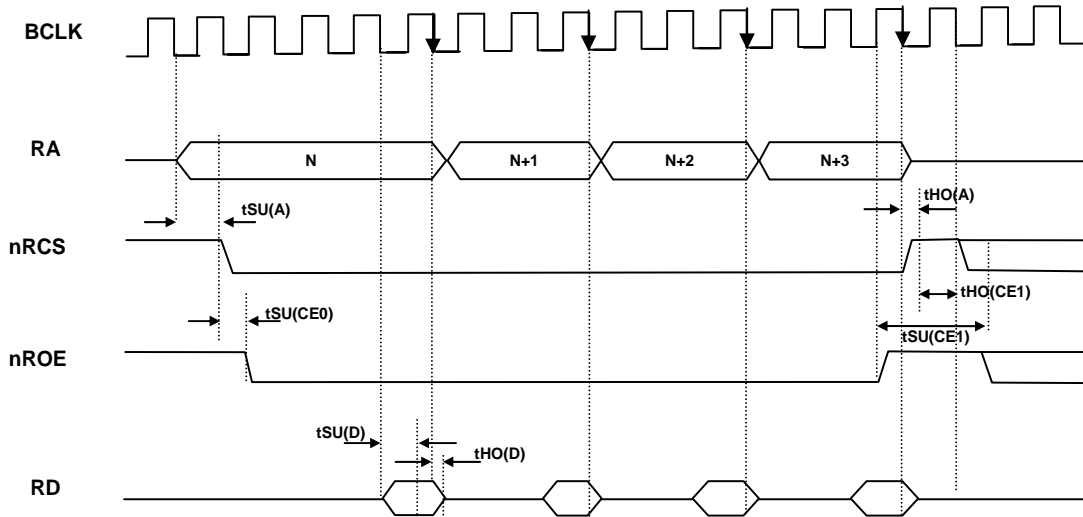

Symbol	Parameter	Min	Max	Unit
tSU(A)	Address to nRCS falling-edge setup time	13		ns
tHO(A)	nROE rising-edge to Address hold time	-15		
tSU(CE0)	nRCS falling-edge to nROE falling-edge setup time	13		
tHO(CE0)	nROE rising-edge to nRCS rising-edge setup time	-13		
tHO(CE1)	nROE or nRWE rising-edge to nRCS falling-edge hold time	25		
tSU(CE1)	nROE or nRWE rising-edge to nRCS falling-edge setup time	50		
tSU(D)	Data setup time before latch	5		
tHO(D)	Data hold time after latch	0		

Timing values for read access in burst mode data transfer

Memory Configuration Register Setting = 0xE00

	11	10	9	8	7	6	5	4	3	2	1	0
	1	1	1	0	0	0	0	0	0	0	0	0

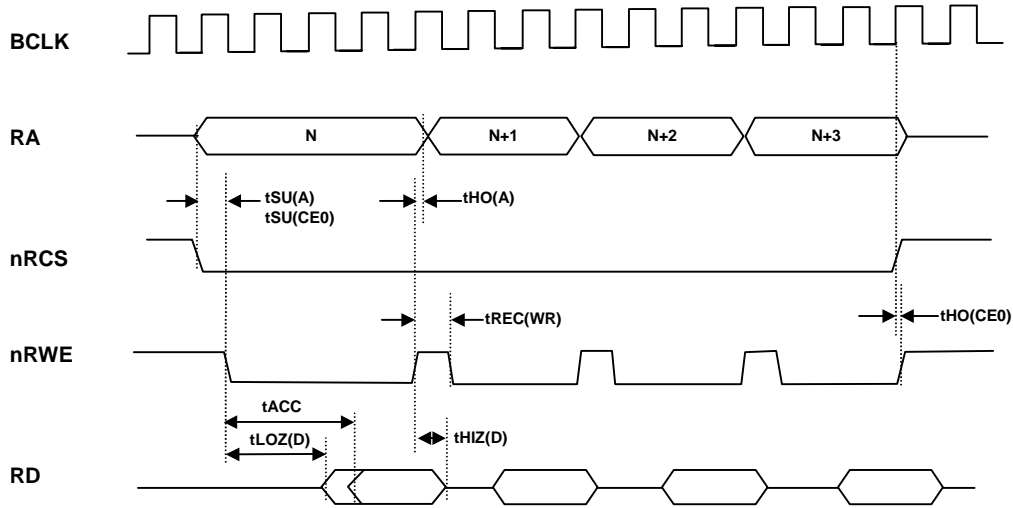
12.5.1.3 WRITE Access Timing

Symbol	Parameter	Min	Max	Unit
tSU(A)	Address to nRWE falling-edge setup time	15		ns
tHO(A)	nRWE rising-edge to Address hold time	0		
tSU(CE0)	nRCS falling-edge to nRWE falling-edge setup time	15		
tHO(CE0)	nRWE rising-edge to nRCS rising-edge setup time	27		
tHO(CE1)	nROE or nRWE rising-edge to nRCS falling-edge hold time	39		
tSU(CE1)	nRCS rising-edge to nROE or nRWE falling-edge setup time	25		
tREC(WR)	nRWE negate to start of next cycle	26		
tHIZ(D)	nRWE rising edge to D Hi-Z delay	25		
tACC	write access time	4.5		
tLOZ(D)	nRWE falling-edge to D driven	0		

Timing values for write access

 Memory Configuration Register Setting = **0x068**

	11	10	9	8	7	6	5	4	3	2	1	0
	0	0	0	0	0	1	1	0	1	0	0	0

12.5.2 SDRAM Interface

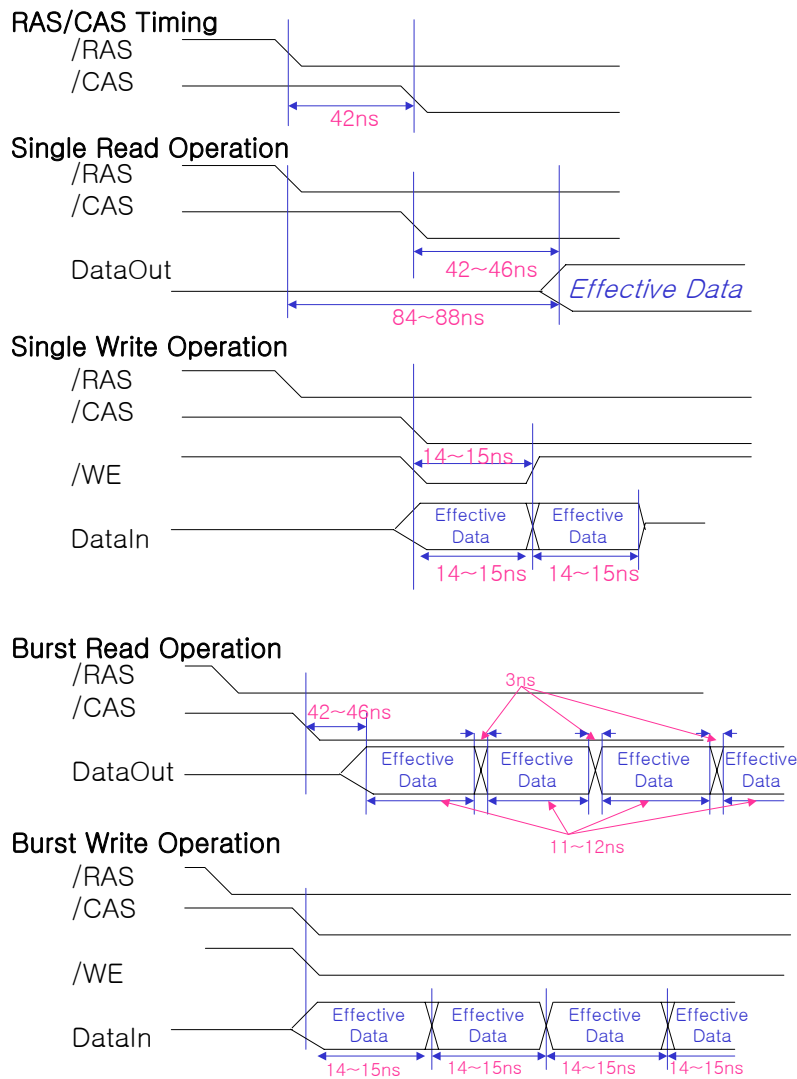

Condition : 70MHz CPU clock speed

12.5.3 LCD Interface

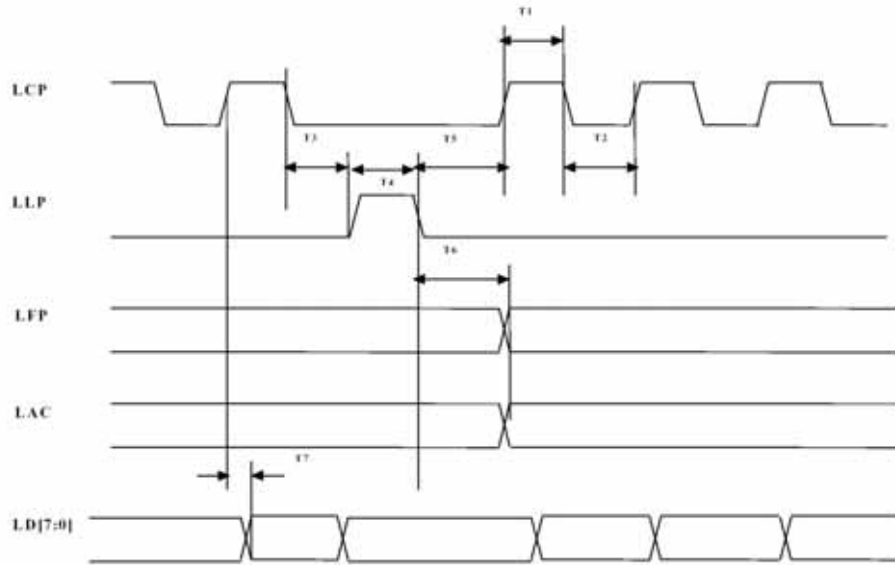

LCD Controller Timing(STN Mode)

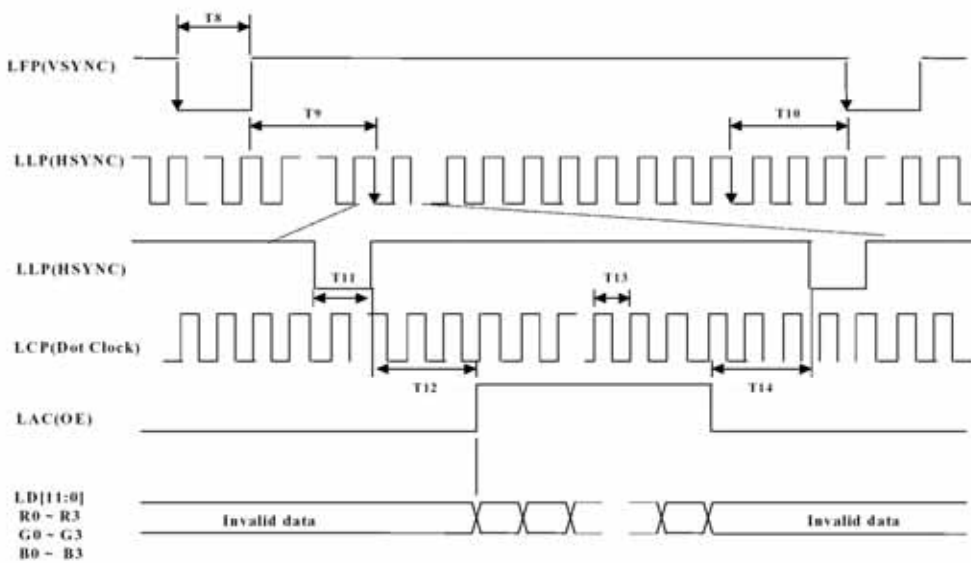

LCD Controller Timing(Active-TFT Mode)

Symbol	Parameter	Min	Typ	Max	Unit
T1	LCP High Time	1	-	16	tCLK(Notes)
T2	LCP Low Time	1	-	17	tCLK
T3	LLP Front-Porch	1	-	256	tCLK
T4	LLP Pulse Width	1	-	256	tCLK
T5	LLP Back-Porch	1	-	256	tCLK
T6	Falling LLP to LFP(LAC) Toggle	1	-	256	tCLK

T7	Rising LCP to Display Data Change	TBD		TBD	ns
T8	VSYNC Width	1		64	tHperiod(Notes)
T9	VSYNC Back-Porch	1		256	tHperiod
T10	VSYNC Front-Porch	1		256	tHperiod
T11	HSYNC Width	1		256	tCLK
T12	HSYNC Back-Porch	1	-	256	tCLK
T13	HSYNC Front-Porch	1	-	256	tCLK
T14	Dot Clock Period	1	-	-	tCLK

LCD Interface Signal Timing Parameters

Note : tCLK is BCLK or VCLK(LCD Controller Internal Clock Source : 31.5 or 40 MHz).

tHperiod Max = 1408 tCLK

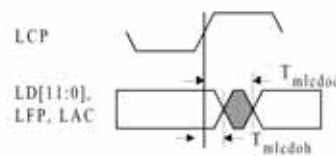
STN Mode Signal Delay

Symbol	Parameter	Min	Max
Tmlcdod	Output Delay Time from LCP rising	-	5
Tmlcdoh	Output Hold Time from LCP Rising	-	-5

STN Mode Signal Delay Parameters

Timing values are derived from simulations using 0pF signal loading. Actual circuit output delays should be calculated by adding manufacturers signal load de-rating delay values.

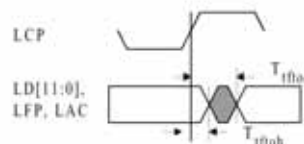
TFT Mode Signal Delay

Symbol	Parameter	Min	Max
Ttftod	Output Delay Time from LCP rising	-	3
Ttftoh	Output Hold Time from LCP Rising	-	-3

TFT Mode Signal Delay Parameters

Timing values are derived from simulations using 0pF signal loading. Actual circuit output delays should be calculated by adding manufacturers signal load de-rating delay values.

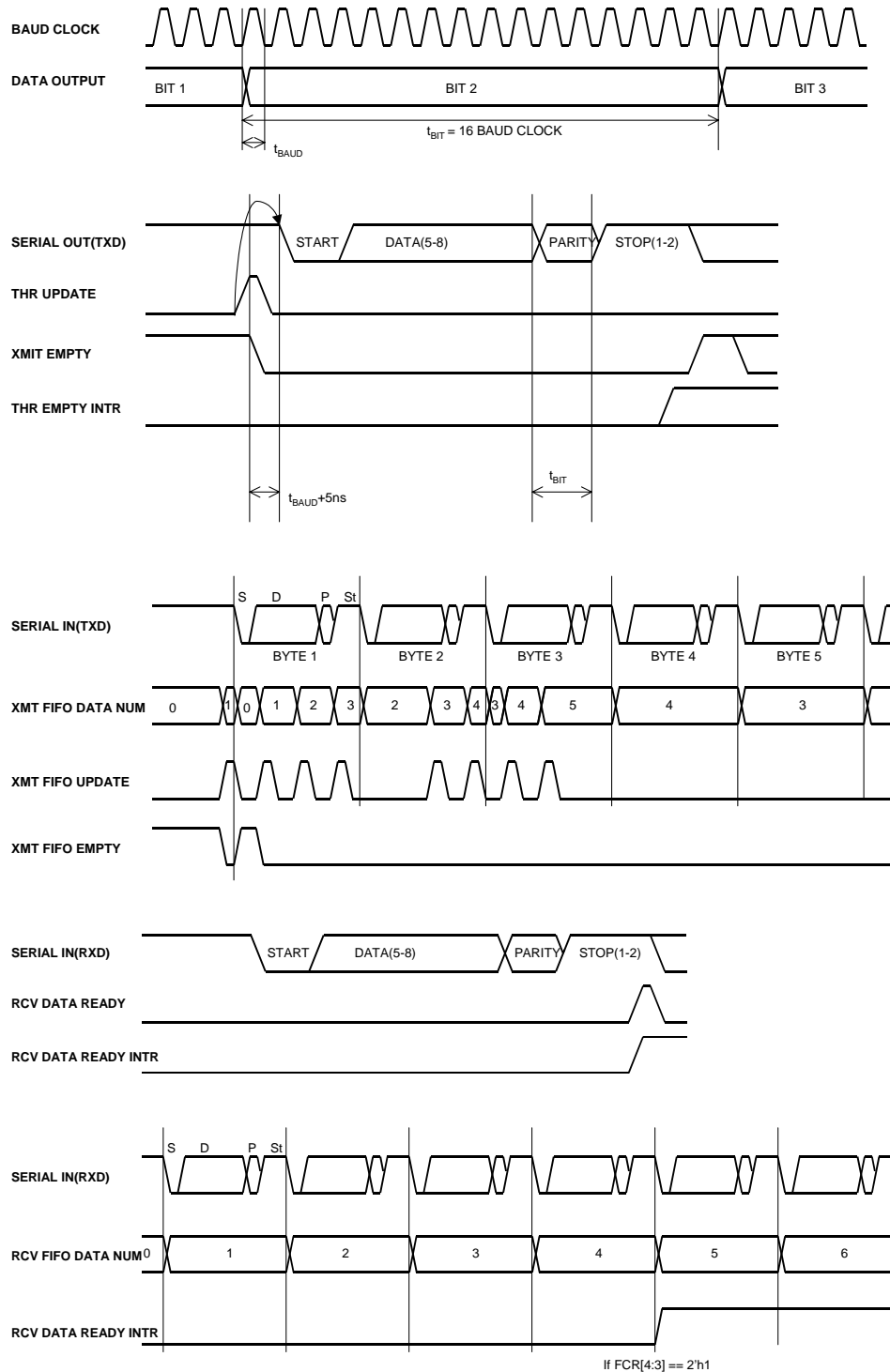
12.5.4 UART(Universal Asynchronous Receiver Transmitter)

12.6 Package

12.6.1 Recommended Soldering Conditions

12.6.1.1 MQFP(Metric Quad Flat Pack) Type

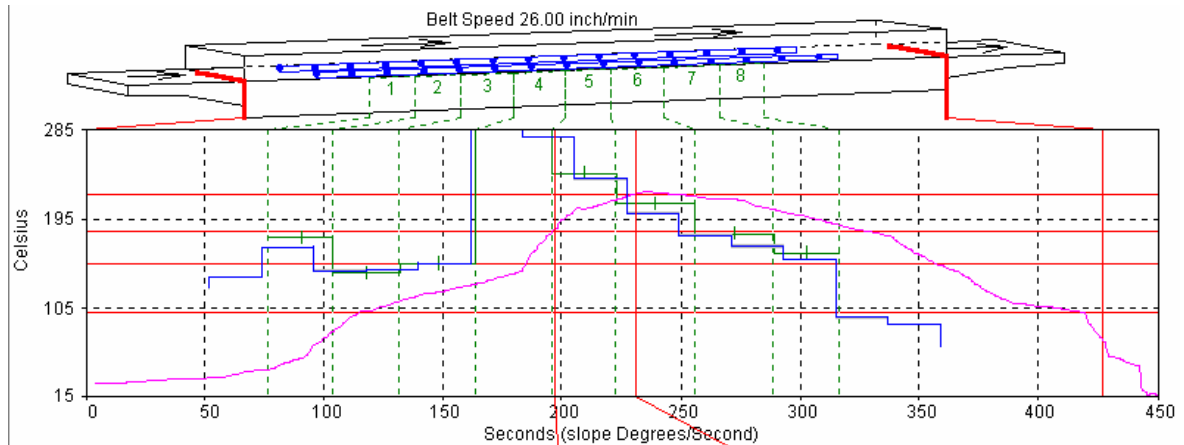

- Recommended IP-Reflow Solder Machine Temperature

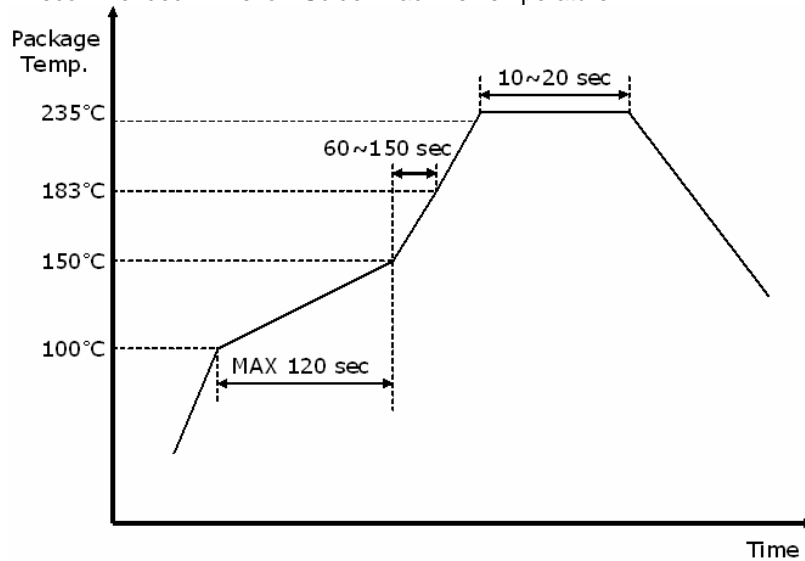

12.6.1.2 FBGA(Chip Array Ball Grid Array) Type

The soldering condition of FBGA type package is the same as that of MQFP type package.

- Recommended IP-Reflow Solder Machine Temperature

12.6.2 Pictures of Package Marking

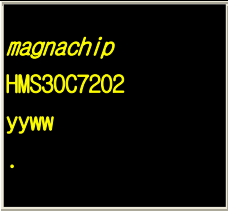
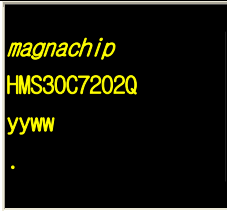
Package Type	256FBGA	256MQFP
Package Marking		

13 APPENDIX

13.1 Deep-sleep, Wake-up Issues of HMS30C7202 PMU

13.1.1 Wake-up

HMS30C7202 has four external wake-up sources, and at least one of two power condition pins (PMADAPOK, PMBATOK) should be high. MRING (nURING), nPMWAKEUP, RTC event can not be masked. PMU only has interrupt mask bits for interrupt controller. It means even though HMS30C7202 wake-up from deep-sleep, there might be no interrupt for interrupt controller. But every time, HMS30C7202 would wake up when any one of wake-up sources asserted.

- **Wake-up sources**

MRING : It's connected nURING pin ("n" of nURING pin means "low active")

This signal can not be masked in PMU.

HOTSYNC : HotSync condition or user defined condition (ex. Plugging power adaptor)

This signal is connected with GPIOB[10] interrupt.

nRESET : nRESET signal wake up from deep-sleep.

nPMWAKEUP : active low external signal. This signal can not be masked.

RTC Event: from RTC. This signal isn't able to mask in PMU.

All wake-up sources are filtered by debounce circuit (except RTC) with 250Hz clock from RTC clock source, so if RTC clock stopped, wake-up sequence would not work.

- **Needed condition for wake-up**

One of PMADAPOK and PMBATOK should be high, it means there's no power problem.

If user wants to make wake-up regardless power source condition, set "WAKEUP" bit of PMU Mode register (PMUMODE) bit [3].

13.1.2 Deep-sleep

- To go deep-sleep state, all wake-up conditions are cleared. If any wake-up pin stays in wake-up condition, 7202 would not go into "deep-sleep mode".

- Once Deep-sleep mode is set (in Slow mode) and no wake-up signal condition, State machine wait, until *Bus Idle* state. And after state machine jump into *Bus Idle*, in the very next "bus access" operation, PMU get bus mastership from CPU and state machine keep going into deep-sleep mode through short sleep state. Sometimes S/W need to wait until *Bus Idle*(ex. DMA cases) and to prevent un-wanted next instruction execution after deep-sleep instruction set PMU Mode Register(PMUMODE), usually dummy loop is used for this purpose.

- In some cases (in some S/W), to keep going into deep-sleep, dummy bus (ex. just single read of a peripheral register) access is helpful after dummy loop. We think it is related with changing bus mastership. (or may need longer dummy loop) But we can't sure it.